

ET42 Compact Tracked Excavator



**WACKER
NEUSON**
all it takes!



PRODUCTIVITY:

- The fuel efficient 46-hp Perkins diesel engine offers class-leading power and performance
- Three-point kinematic bucket linkage system enables a 200° bucket rotation for excellent breakout force, greater digging depth and dumping height
- Load sensing hydraulic system allows consistent and precise control regardless of the load
- Hydraulic quick connect system allows the operator to change attachments from the cab

COMFORT / CONVENIENCE:

- Exceptional visibility-low profile hood and large windows allows view of front of both tracks and the offset boom provides a complete view of boom, attachment and work area
- Cab offers standard air conditioning and unique four position windshield providing fresh air and easy communication
- Operator comfort features include conveniently located controls, including an electronic ISO/SAE changeover switch and easy-to-read 3.5-inch color display
- Dual flange rollers in the undercarriage improve stability and provide smoother ride with less vibration

FEATURES:

- Easy to transport with eight large tie down lugs and total machine weight under 10,000 pounds
- Large engine hood provides easy access to service points
- All boom/arm cylinders have a protective covering to reduce damage and save on repair costs.
- ET42 is available in cab or canopy with LED working lights and optional angle blade.

ET42

Compact Track Excavator



**WACKER
NEUSON**
all it takes!

	DIMENSIONS	UNIT	ET42
A	Height	in	98.3
B	Width	in	67.77
C	Transport length long dipper	in	202.75
D	Max digging depth (long dipper)	in	139.63
E	Max. vertical dig depth (long dipper)	in	90.34
F	Max. dig height (long dipper)	in	210.4
G	Max. dump height (long dipper)	in	145.9
H	Max. digging radius (long dipper)	in	223.71
I	Max. reach at ground (long dipper)	in	219.46
J	Minimum tail end swiveling radius	in	52.6

	OPERATING DATA	UNIT	ET42
	Shipping weight min.	lbs	8,598
	Operating weight min	lbs	8,818
	Breakout force max.	lbf	9,847
	Biting force max.	lbf	4,676
ENGINE / MOTOR		UNIT	
	Manufacturer		Perkins
	Type		403J-E17T
	Motor		Liquid-cooled 3-cylinder turbo engine
	Displacement	in ³	101.4
	Speed	rpm	2,800
	Performance	hp	46
	Battery	Ah	77
	Fuel tank capacity	gal	22
HYDRAULIC SYSTEM		UNIT	
	Duty pump		1 axial piston pump
	Flow rate	gal/min	10.57 + 26.16

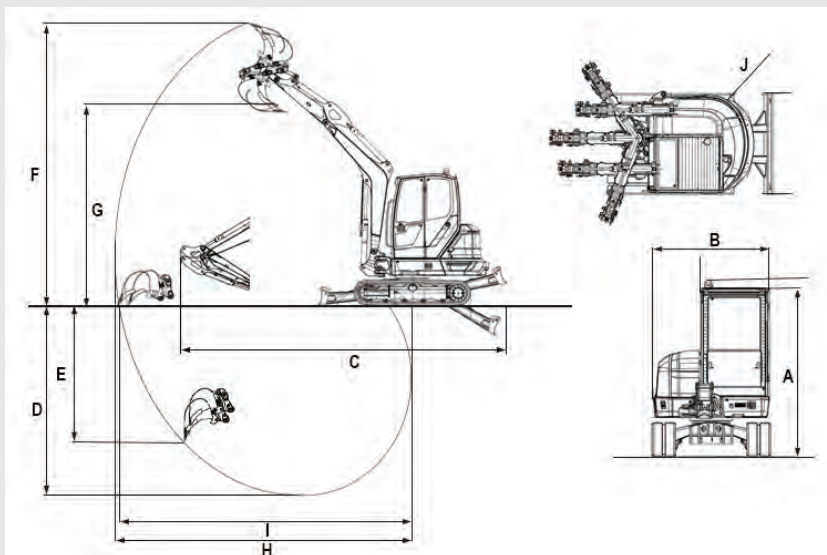

www.wackerneuson.com