



SSR120C-8

Roller



KEY FEATURES

- Powered by Cummins T4F QSB4.5 rated at 160 HP. Fuel efficient and environmentally friendly
- Electronically controlled travel and vibratory functions result in increased operator efficiency
- Reverse camera and heated, air suspension seat provide operator safety and comfort
- CE certified

Operating Weight

12t - 26,455lb

Rated Power

119kW - 160 HP

Excitation Force

280/178 kN - 62,947/40,016 lb

Vibration Frequency

32/36Hz

SSR120C-8 Dimensions & Specifications

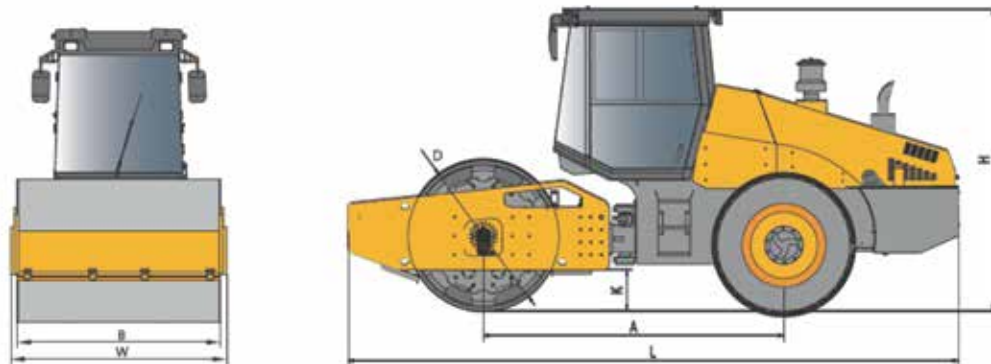

OVERALL DIMENSIONS

	Standard	Metric
A	9' 8"	2950 mm
W	7' 4"	2240 mm
L	18' 10"	5750 mm
D	4' 11"	1500 mm
H	10' 6"	3190 mm
B	7' 0"	2130 mm
K	19"	480 mm

MACHINE PARAMETERS

	Standard	Metric
Operating Weight	26,455 lb	12,000 kg
Weight at Drum	15,432 lb	7000 kg
Weight at Rear Axle	11,023 lb	5000 kg
Drum Static Linear Load	29 lbf/in	329 N/cm
Vibration Frequency	32/36 Hz	
Nominal Amplitude	.07/035 in	1.8/0.9 mm
Excitation Force	62,947/40,015 lbf	280/178 kN
Drum Diameter	4' 11"	1500 mm
Drum Width	7' 0"	2130 mm
Drum Edge Thickness	1"	25 mm
Travel Speed	0-8.2/0-10.1 km/h	
Gradeability	55%	55%
Ground Clearance	1' 7"	480 mm
Wheel Base	9' 8"	2950 mm
Steering Angle	±35°	
Swing Angle	±12°	
Min. Turning Outside Diameter	38' 1"	11,600 mm
Tires	23.1-26-8PR	
Model	Cummins QSB4.5-C160	
Emissions	Tier 4	
Rated Power	160 hp	119 kW
Battery, V×Ah	24	
Fuel tank	53 gal	200 L
Hydraulic oil tank	32 gal	120 L

SANY America Inc.

318 Cooper Circle | Peachtree City, GA 30269
T: 678-251-2810 | F: 770-632-7820

www.sanyamerica.com

