



CAT[®] F-SERIES PAVERS AND SCREEDS

BUILT FOR IT.™



CONTENTS

Cat Features	4, 5
Paver Features and Specifications	
Integrated Generator	6, 7
Fuel Efficient Engines	8, 9
Operating Environment	10, 11
Operating Console	12, 13
Material Delivery	14, 15
Wheel Undercarriage	16, 17
Mobil-Trac™ Undercarriage	18, 19
Steel Track Undercarriage	20, 21
Paver and Screed Compatibility	22
AP500F	23
AP555F	24
AP600F	25
AP655F Mobil-Trac	26
AP655F Steel Track	27
AP1000F	28
AP1055F	29
Screed Overview	30, 31
Tamper-Bar System	32, 33
Screed Controls	34, 35
SE50 V Screed	36
SE50 VT Screed	37
SE60 V Screed	38
SE60 V XW Screed	39
SE60 VT XW Screed	40
Wide Width Screed Features	41
Screed Extensions	42, 43
Cat® Grade Control	44, 45
Product Link™	46
Customer Support	47
Mobile Apps	48, 49
Training and Solutions	50, 51



^ **AP555F/SE50 V**
Urban Street



^ **AP500F/SE8**
Rural Road



^ **AP655F/SE60 VT XW**
RCC Mix



^ **AP1055F/SE60 V XW**
Residential Street

PAVING ROADS

ALL DAY. EVERY DAY.

At Caterpillar Paving Products, all we think about is paving. Worldwide, no other manufacturer has more people dedicated to helping paving customers increase productivity, quality and profitability than Caterpillar.

Our line of Cat pavers and screeds reflect that dedication, providing customers with durable, reliable and versatile machines that lower risk and increase mat quality.

We invite you to compare our pavers side-by-side with competitive machines—the quality and value of our machines will stand out. Visit your local Cat dealer today and see what makes Caterpillar the first choice of paving customers around the globe.



^ **AP600F/SE50 VT**
Pathway



^ **AP1055F/SE60 VT XW**
RCC Mix



^ **AP1000F/SE60 V**
Highway



^ **AP655F/SE8**
Urban Street

SIMPLY ADVANCED

TECHNOLOGY BOOSTS PERFORMANCE

HIGH RETURN ON INVESTMENT

- Higher resale value: long-life components, and latest engine emission technology
- Exclusive 70 kW integrated generator, designed for long life by the same team that developed the D7E electric drive track-type tractor
- Fast heating screed leads to more daily production, heating time in as little as 15 minutes from 5° C to 130° C (41° F to 266° F)
- Undercarriage designs limit tow-point movement for excellent paving results
- Exclusive air flow improves operating conditions for the crew and keeps components cooler for lasting durability

QUALITY RESULTS, IMPROVED EARNINGS

- SE-Series screeds deliver excellent ride, density, and mat texture while providing superior adjustment capabilities up to 10.0 m (33')
- Tamper-bar screeds provide excellent pre-compaction for higher densities behind the screed
- Tow-point utilizes exclusive linkage design for optimal screed flotation
- 2-speed proportional control on the screed extenders provides versatile control

ADVANCED TECHNOLOGY

- Exclusive screed heating system monitors elements for failure conditions, eliminates unnecessary replacement
- Cat Grade Control option integrated into the tractor and screed displays for optimized operator efficiency
- Propel and feeder system settings transfer between stations with a single switch; Cat exclusive
- Auto-fill feeder system simplifies setup
- Single touch feeder system activation optimizes efficiency
- Automated travel feature; augers and hydraulic mainframe extensions raise with the screed, preventing damage during transport
- Product Link remotely monitors machine location, daily hours of operation, fuel consumption, fault codes, and preventative maintenance status, for optimal machine support

Performance improvements and technology with a customer-friendly interface are key benefits of the new F-Series Pavers.



"We have hit our target specs on all the jobs it's worked on. It's the paver we use to reach smoothness!"

– Cat Paving Contractor

LOWER OWNING AND OPERATING COSTS

- Exclusive Eco-mode and Automatic Engine Speed Control reduce fuel consumption and lower sound levels for better comfort and communication
- 4-pump feeder system is designed for high production in Eco-mode, leads to lower fuel consumption
- Million cycle keypad switches
- Conveyor bed plates and chain guards designed to minimize labor requirements and provide lower cost replacement
- Heating elements slide-out for easy replacement
- Machined screed frames simplify screed plate leveling

UNMATCHED AFTER-THE-SALE SUPPORT

- Strategically located dealers with 24/7 support
- In-the-Iron service training for technicians
- Paver Operator Training helps maximize machine performance
- Project consulting helps improve technique and job site management



QUICK STARTER

INTEGRATED GENERATOR SAVES TIME AND FUEL

FASTER HEAT, LOWER FUEL CONSUMPTION

Exclusive 70 kW Integrated Generator

- Developed by the same team that designed D7E electric drive, track-type tractor
- Designed to last for the life of the paver, oil-cooled, direct drive delivers reliable performance
- Fast heating leads to less waiting, reduced fuel consumption, and more daily production
- Even heat distribution throughout the screed plates

EXCLUSIVE SYSTEM MONITORING

- Exclusive system monitors heating elements for failure conditions, eliminates unnecessary replacement
- Temperature zone monitoring allows heating to continue in the event of a temperature sensor failure
- Warning/failure indicators delivered through the LCD displays
- Heating system can be monitored through Product Link

QUIET OR QUICK HEATING OPTIONS

Quiet Heat

- Low sound levels
- 1300 rpm engine speed
- 15 minute heating time to 130° C (266° F) from 5° C (41° F) ambient temperatures at standard paving widths
- 35 minute heating time to 130° C (266° F) from 5° C (41° F) ambient temperatures when equipped with wide width extension packages

Quick Heat

- Wide-width paving packages only
- Note: At standard widths quick heat will not heat any faster than quiet heat*
- Variable engine speed, adjusts to the minimum required rpm
- 25 minute heating time to 130° C (266° F) from 5° C (41° F) ambient temperatures when equipped with wide width extensions packages

“The screed heats more quickly at the start of the shift and the even heat throughout the screed is essential to preventing segregation.”

– Cat Paving Contractor



JOB SITE POWER

- Easily power ballasted lighting configurations
- Full power at 1000 rpm
- 6.6 kW of available power

@120 volts/60 Hz

Eight, 120 volt GFCI outlets w/ breaker resets

@240 volts/50 Hz

Two, 240 volt GFI/RCD breakers

@120 volts/50 Hz

Four, 120 volt GFCI/RCD breakers

**Configurations vary by region, contact your dealer for more information.*



High-powered generator easily powers nighttime lighting configurations.



Quiet or quick heating made easy through the LCD display. Quick heating offers time-savings when utilizing wide-width packages.



Three preset heating options provide a wide range of temperatures for various mix designs.

FUEL EFFICIENT AND QUIET

TECHNOLOGY, INCLUDING ECO-MODE
OPTIMIZE POWER





ENGINES

U.S. EPA Tier 4 Final/EU Stage IV Engine Features

- Self-Activating Regeneration
 - Easy-fill DEF tank, assists with regeneration
 - 19.1 L (5 gal) capacity
 - Refill when fueling
- Ultra Low Sulfur Diesel (ULSD) fuel is required
(Bio-diesel up to B20 can be utilized when blended with ULSD, refer to the Cat Fluids Guide for more information)
- Engine oil must meet Caterpillar ECF-3, API CJ-4/ACEA E9 specifications

The following engines meet U.S. EPA Tier 4 Final and EU Stage IV emission standards.

Machine	Engine	Power Rating at 2200 RPM
AP500F AP555F	Cat C4.4 ACERT	106 kW, 144 hp (M), 142 hp (I)
AP600F AP655F Mobil-Trac AP655F Steel Track	Cat C4.4 ACERT	129 kW, 175 hp (M), 173 hp (I)
AP1000F AP1055F Mobil-Trac	Cat C7.1 ACERT	168 kW, 228 hp (M), 225 hp (I)

(M) Metric Horsepower
(I) Imperial Horsepower

The following engine meets emissions equivalent to U.S. EPA Tier 3, EU Stage IIIA and China Stage III requirements.

Machine	Engine	Power Rating at 2200 RPM
AP500F AP555F	Cat C4.4	106 kW, 144 hp (M), 142 hp (I)
AP600F AP655F Mobil-Trac AP655F Steel Track	Cat C7.1	151 kW, 205 hp (M), 202 hp (I)
AP1000F AP1055F Mobil-Trac	Cat C7.1	186 kW, 252 hp (M), 249 hp (I)

(M) Metric Horsepower
(I) Imperial Horsepower

REDUCED FUEL CONSUMPTION AND LOWER SOUND LEVELS

Don't waste fuel or power, Eco-mode and Automatic Engine Speed Control combine to optimize engine speed and deliver the power when needed. F-Series pavers improve fuel efficiency by 5% over the E-Series pavers and up to 20% over some other manufacturers.

Eco-mode

- Eco-mode, utilizes an engine speed of 1650 rpm for reduced fuel consumption and lower sound levels
- Well suited for most applications

Automatic Engine Speed Control

- Engine operates at 2200 rpm when the propel lever moves from neutral
- When activated, engine speed is reduced to idle speed of 1000 rpm when the propel lever is moved to neutral or to 1300 rpm when screed heat is active

Advanced Eco-mode

- Combines Eco-mode and Automatic Engine Speed Control
- Engine speed increases to 1650 rpm when the propel lever moves from neutral
- Modifies engine speed based on load
- If the upper power threshold is exceeded, the engine speed will increase to 2200 rpm and remain there until the load drops below the minimum threshold and remains there for 30 seconds

MORE COMFORT FOR YOUR CREW

FIGHT FATIGUE, IMPROVE PERFORMANCE

BETTER VISIBILITY

- Dual independent stations can extend beyond the frame for good all-around visibility, also offer backup capability
- Low profile front-mounted cooling system improves forward visibility
- The auger assembly has been redesigned to improve visibility into the auger chamber
- 12-volt power receptacle, supports communication devices
- Upper and lower tow-point indicators simplify height adjustment for tractor and screed operators

EXCEPTIONAL COMFORT

- Heated seat option, pneumatic suspension, multiple adjustments, and tilting consoles provide day-long comfort
- Quiet operation supports clear communication
- Cup holders offer convenience
- Intuitive touch screen color display keeps the operator informed and in control
- USB port simplifies software updates



Machine settings automatically transfer between stations, simply press the button to resume paving.





The ventilation system draws fumes from the conveyor tunnel as well as the auger chamber and redirects them away from the operator for a more comfortable working environment.

COOLER AND QUIETER

AIRFLOW DIRECTS FUMES AND SOUND AWAY FROM THE CREW

BETTER OPERATING CONDITIONS

- Operator-friendly environment
- Top-mounted cooling system directs fumes, hot air, and fan noise away from crew
- Cooling system redirects fumes surge that occurs when mix is dumped into the hopper
- Ventilation system removes and redirects vapors from the conveyor tunnels and auger chamber



EASY ADJUSTMENT

TECHNOLOGY HELPS OPERATORS PERFORM



TOP FEATURES

1. Automated Hopper Functions
2. New Mix Delivery Technology
3. Million Cycle Switches
4. Water Resistant Console and LCD Display
5. Integrated Cat Grade Control
6. Generator Activation
7. Day or Night Brightness Control
8. Eco-Mode and Automatic Engine Speed Control
9. Automatic Station/Settings Transfer

EASY RECOGNITION

- Multiple language options
- Intuitive symbols and large graphics simplify operation
- Adjustable brightness control for easy viewing day or night
- Raised switch design enables easy recognition for better efficiency and performance

INTERACTIVE LCD DISPLAY

- Touch-screen access to:
 - Generator activation, auxiliary power
 - Screed temperature control
 - Tamper and vibratory speeds
 - Mix height adjustment, *previously only available from the screed console*
 - Service code information
 - Screed heating zones
 - Integrated Cat Grade Control
 - Stored operator preferences

EXCEPTIONAL DURABILITY

- Water resistant for excellent reliability, meets IP67 common water submergence ratings
- Durable million cycles switches
- Grouped component replacement, no need to replace the entire console
- Durable switch cover withstands extreme conditions



The AP655F steel track model utilizes a dial in place of the standard steering wheel.



MATERIAL DELIVERY

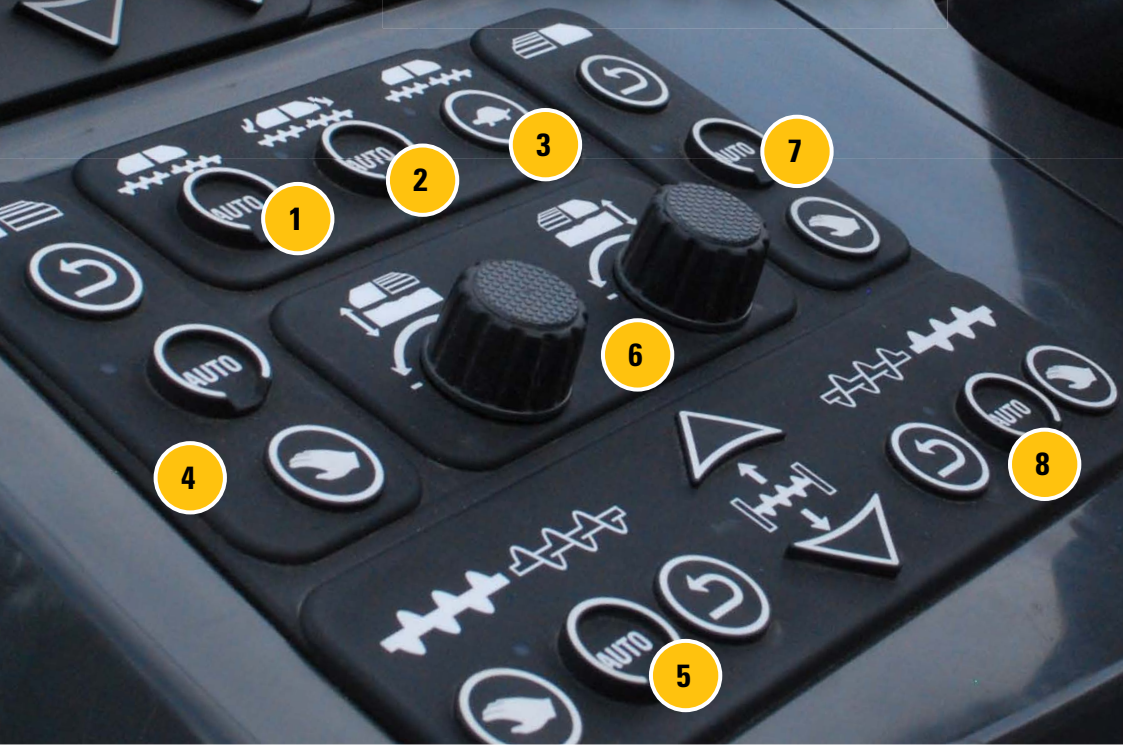

MIX DELIVERY

1. Single-Touch Feeder System
2. Auto-Fill System
3. Warm-up, Clean-out Mode
4. Left Side Conveyor Controls
5. Left Side Auger Controls
6. Conveyor Ratio Control Dials
7. Right Side Conveyor Controls
8. Right Side Auger Controls

HIGH PRODUCTION FEATURES

- 4-pump feeder system is designed with oversized components for high production in Eco-mode
- Wide tunnel and optimally spaced conveyor bars ensure smooth flow to the auger chamber
- Push-roller includes four horizontal and two vertical positions that conform to various trucking fleets for smoother exchanges
- Thick floor plates and robust hopper design easily handle hopper inserts

EASY OPERATION

Auto-Fill Feeder System

- Simplifies starts by alternating the conveyors and augers until the mix height reaches the sensor set point

Single-Touch Feeder System

- Automatically activates the entire feeder system with a single button for better efficiency

One-Touch Hopper Control

- The hopper wings and front hydraulic apron (if equipped) can be folded with a single touch and release
- The system can be tailored to activate left or right wings together or independently, with front hydraulic apron, or all three together

Cleanout/Warmup Mode

- Activates the augers, conveyors, and tamper bar (if equipped) in slow speed, enables the application of release agents to prevent material build-up

Mix Height Adjustment

- Mix height adjustment from the tractor LCD display offers more control, previously only available from the screed

The paver takes off nicely with no noticeable joints, yields a quality ride!

– Cat Paving Contractor

IMPROVED DESIGNS

New Components

- Thicker conveyor chain guards, heavy-duty chains, and stout conveyor bars deliver lasting performance and lower lifetime operating costs
- The auger assembly has been angled toward the tractor for better visibility and material flow
- Standard entry and low entry hopper designs for the AP1000F and AP1055F
 - Easily accept hopper inserts
- Low entry hopper design maintains a flat profile for an enhanced truck interface
 - Low entry design is wider than the standard entry hopper

Hydraulic Mainframe Extensions

- The optional 457 mm (18") hydraulic mainframe extensions attach to the auger assembly and provide smooth material flow out to the extenders

Automated Travel Mode

- The augers and hydraulic mainframe extensions can be tailored to raise when lifting the screed, this unique feature prevents damage to the augers from curbs and man-hole covers when moving around the job site

Easier Service

- Hardware-free bed plates simplify replacement
- Bottom-side mounting hardware for the chain guards eliminates bolt wear and material build-up for easier replacement

FEED SENSOR OPTIONS

Zero Sensor Paving (manual)

- Set the feeder system to automatic and adjust the mix height setting, no need to hold the manual switch and run full on/off as previous models required

Two Sensor Feeder System

- Utilizes ratio control to automatically adjust mix flow, mechanical or sonic sensors available

Four Sensor Feeder System

- Utilizes 2 sensors to control the conveyors and 2 sensors to control the augers, mechanical or sonic sensors available

Low Entry Hopper

Standard on all models.



Standard Entry Hopper

AP1000F, AP1055F option



Hydraulic Mainframe Extension

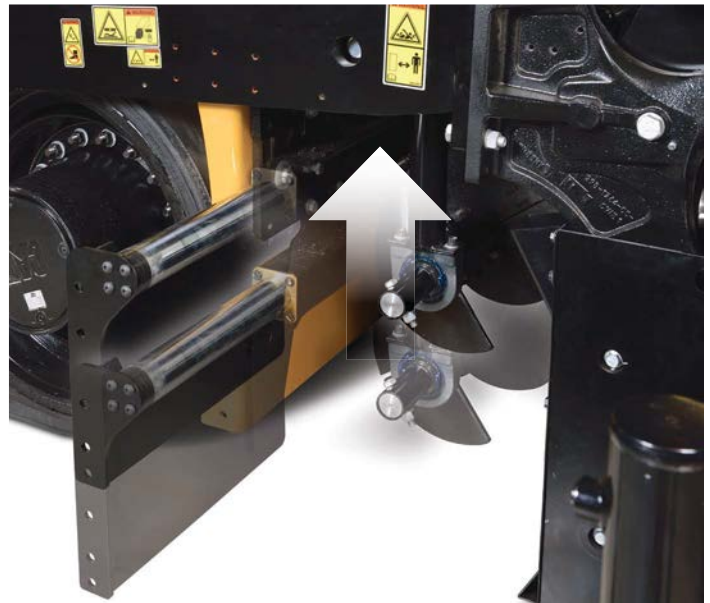

Feed Sensor Options





Adjustable front wheel assist and all-wheel drive torque prevent slippage for better traction and mat quality.

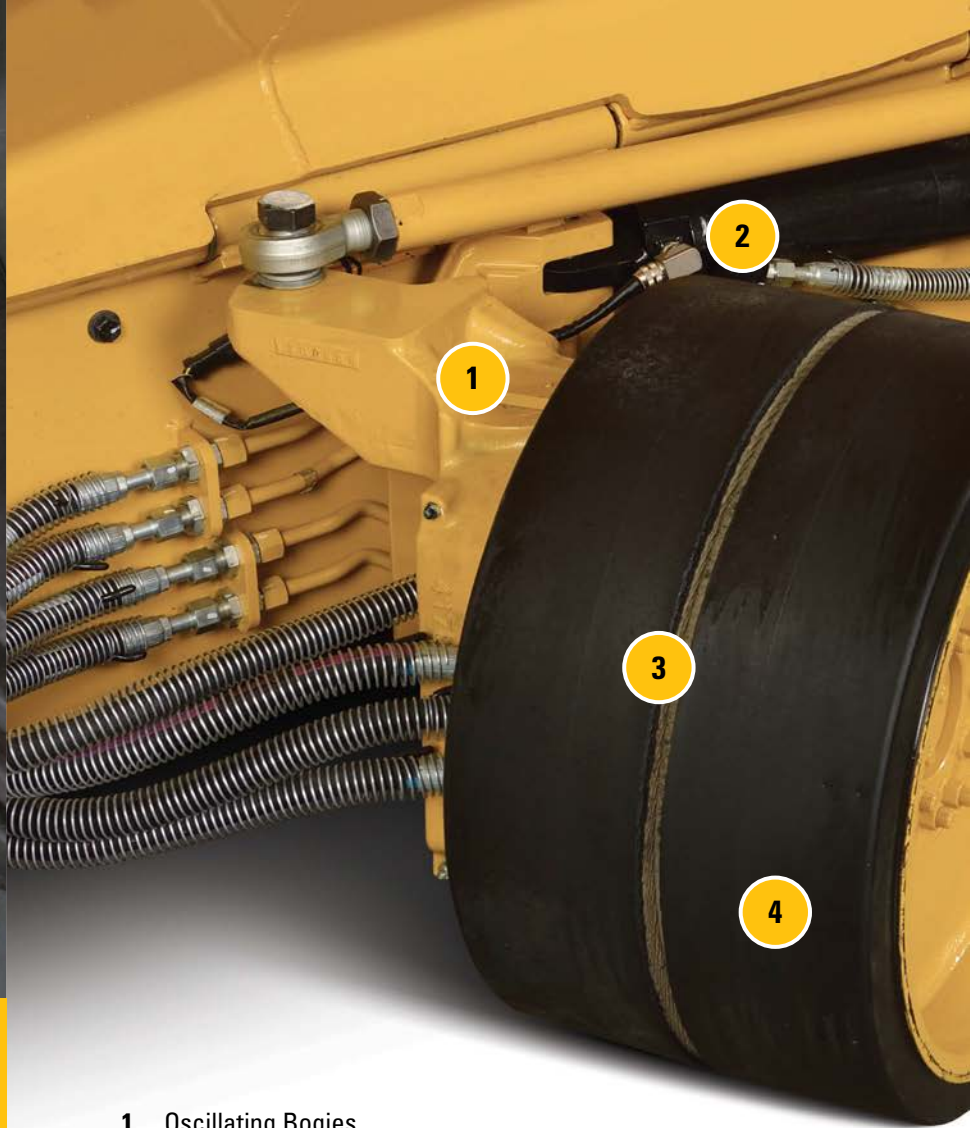

1. Oscillating Bogies
2. Steering Position Sensor
3. Dual Solid Front Steering Wheels
4. Front Wheel Assist
5. All-Wheel Drive
6. Large Drive Tires

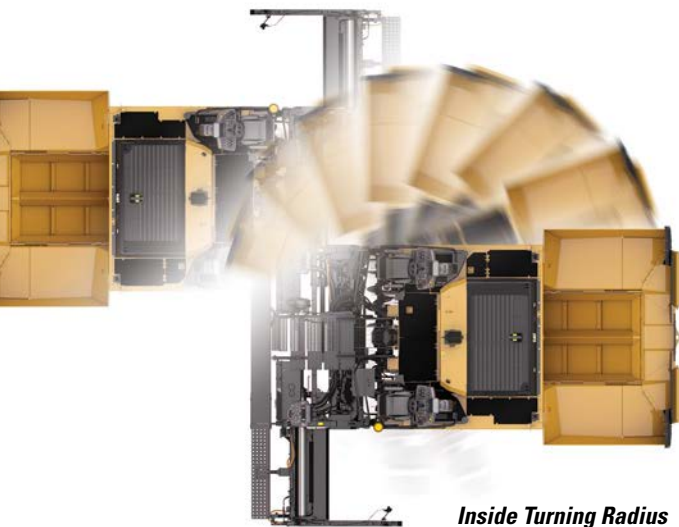

Quick reacting speed control ensures that responsive power is immediately available, while the wheeled undercarriage provides mobility and high speed capability when moving around the job site.



RESPONSIVE POWER

OPTIONS ADD PULL

EXCELLENT MANEUVERABILITY

- Tight turning radius for quick mobility
- The oscillating design easily overcomes obstacles, eliminates jarring effects and minimizes tow-point movement
- New radial tire design improves traction by up to 20% over previous series tires (AP1000F only)

Power Turning System

- A position sensor located in the left steering cylinder helps maintain consistent travel speeds when making turns by adjusting the drive speed of the propel motors according to the steering angle of the front wheels, leading to better mat quality and less wear on the drive system
- Provides power and traction to push trucks through turns

MOBILITY

- Pave, Travel and Maneuver modes
 - Pave: Improved steering control when paving
 - Travel: Maximum speeds
 - Maneuver: Optimizes steering control and delivers a tight inside turning radius:
 - AP500F – 0.35 m (1.15')
 - AP600F – 1.4 m (4.5')
 - AP1000F – 0.5 m (1.5')

FRONT WHEEL ASSIST OR ALL-WHEEL DRIVE

Four Wheel Drive (Option)

- Provides power to the front two bogie wheels for added traction when pushing trucks or working on soft base
- Dedicated pump delivers a 50% increase in front wheel torque over previous models for better traction

All-Wheel Drive (Option)

- Provides power to the front and rear bogie wheels, maximizing traction
 - 200% increase in pull force over previous models

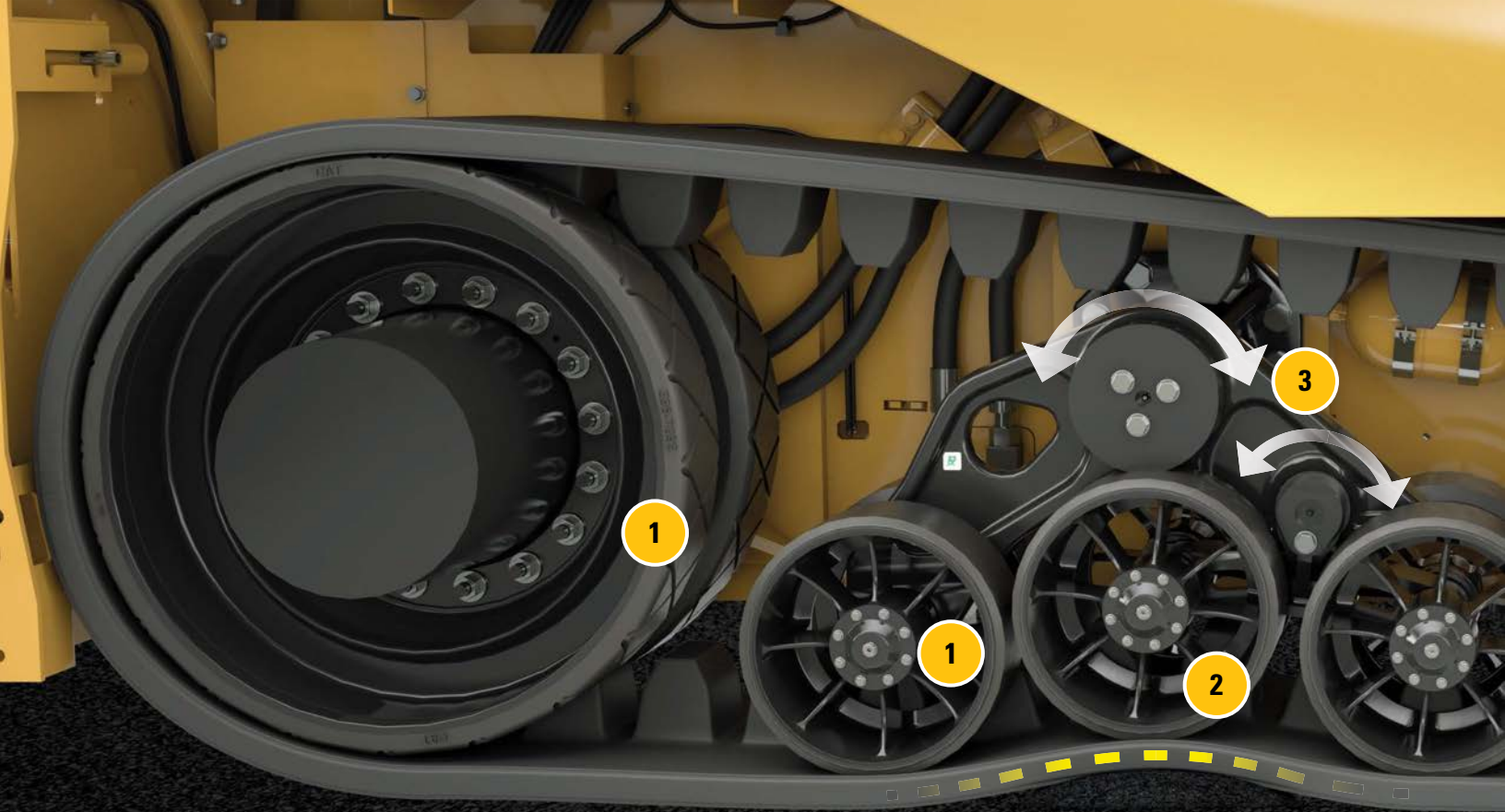

EXCELLENT TRACTION HIGH SPEEDS

MOBIL-TRAC DELIVERS RIDE SIMILAR
TO WHEELED PAVERS

Maintenance-free and unmatched traction in both a smooth or tread-bar style belt; the Mobil-Trac™ undercarriage provides excellent flotation, smooth travel, and high speed capability.

MOBILITY

- High speed capability; similar to wheeled pavers
- Pave, Travel and Maneuver modes
 - Pave: Improved steering control when paving
 - Travel: Maximum speeds
 - Maneuver: Optimizes steering control and enables the paver to rotate within its own footprint

DURABILITY

- Self-tensioning accumulators, center guide blocks and rugged internal belt cables ensure durability
- Rubber-coated components designed to shed asphalt and prevent accumulation

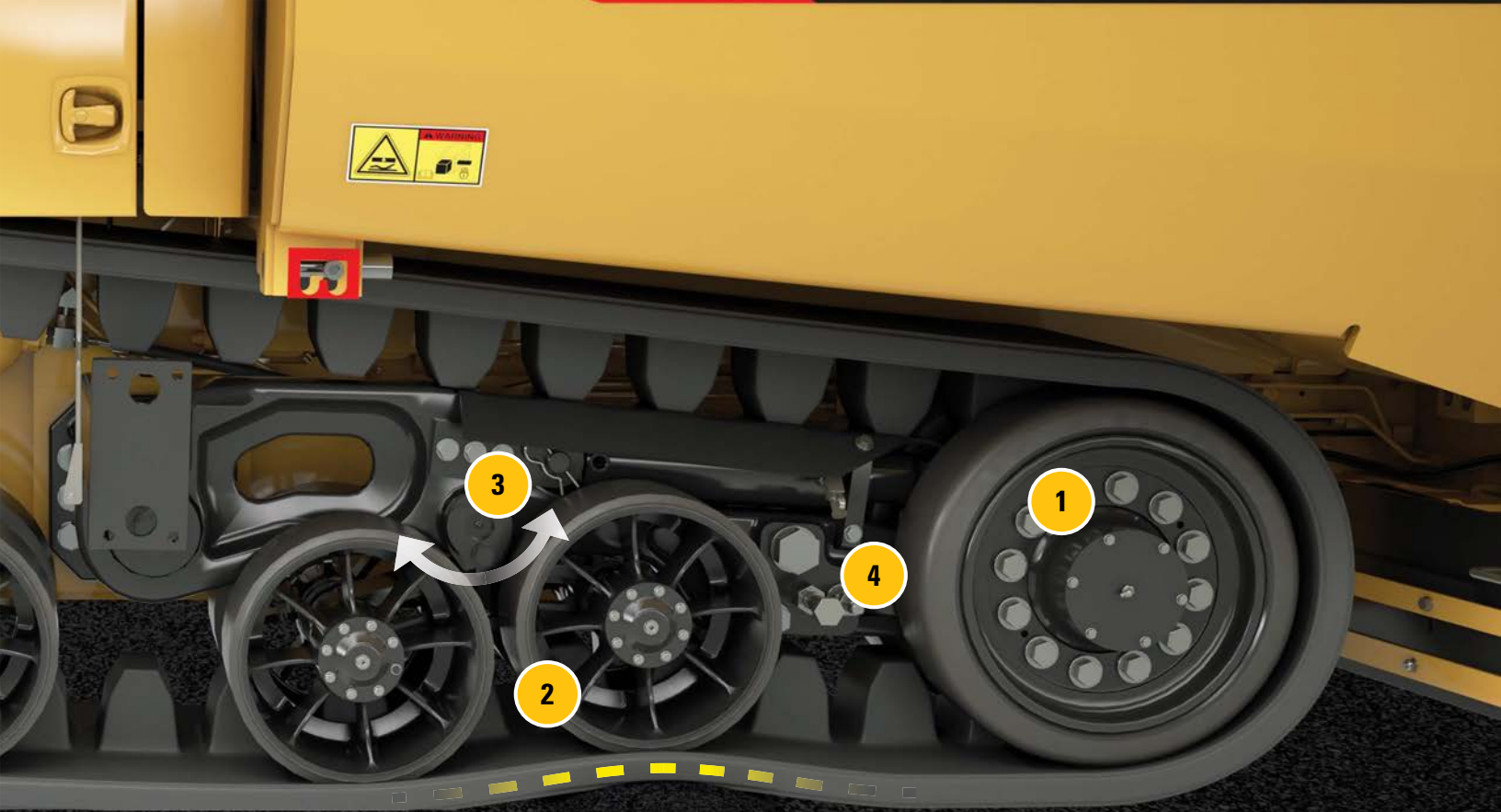

1. Rubber-Coated Components
2. Oscillating Bogies
3. Pivot Point
4. Automatic Belt Tensioning
5. Smooth Belt
6. Tread-bar Belt

SMOOTH RIDE

- Oscillating bogie design delivers ride similar to wheeled paver
- Pivoting design eliminates jarring effects caused by milled cuts
- Guide lugs keep the tracks centered for reliable performance

PERFORMANCE

- Mobil-Trac undercarriage design minimizes tow-point movement
- Front and rear bogie sets crawl over obstacles; maintain ground contact and minimize tow-point movement
- Smooth belt performs well on soft base materials and fresh mats
- Tread-bar belt excels on loose paving/transport conditions
- Outstanding traction in any condition
- Excellent flotation and low ground pressures due to the large track area





STEEL TRACK (AP655F)

UNIQUE BOGIE SYSTEM DELIVERS SMOOTH RIDE

Low maintenance design with oscillating bogie sets and large track pads provide excellent flotation and smooth travel.

EVEN WEIGHT DISTRIBUTION

- Quad rear bogie design provides even weight distribution for excellent traction and a smooth ride
- Pave, Travel and Maneuver modes
 - Pave: Improved steering control when paving
 - Travel: Maximum speeds
 - Maneuver: Optimizes steering control and enables the paver to rotate within its own footprint

EXCELLENT FLOTATION

- Large footprint of 3048 mm by 356 mm (120" x 14") offers good performance on soft base materials

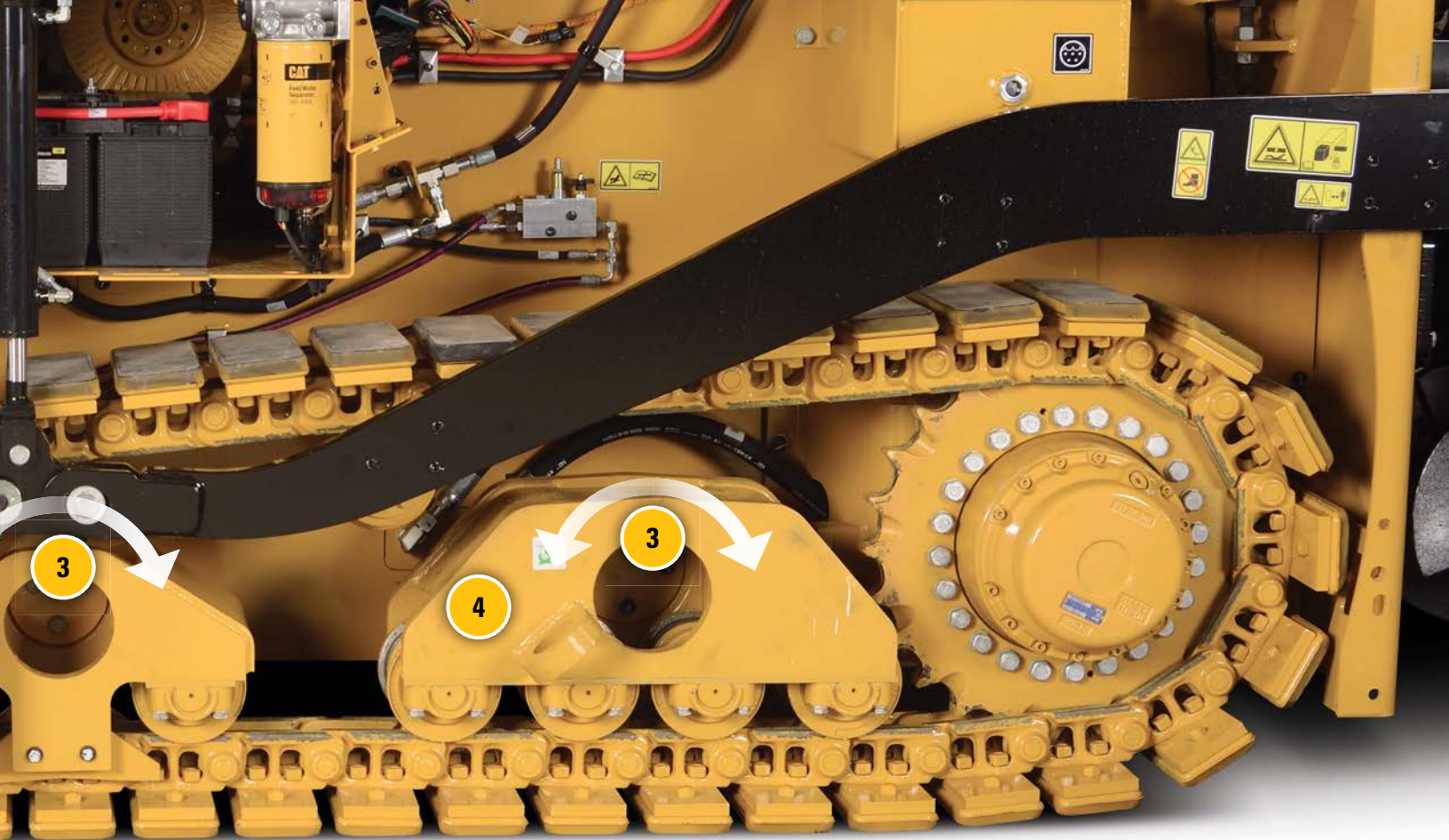

1. Track Plow
2. Automatic Track Tensioning
3. Pivot Point
4. Quad Rear Bogie

DURABLE COMPONENTS

- Track components similar to the Cat Track-Type tractors ensure reliability
- Bonded track pads containing unique compounds provide excellent wear characteristics

TRACK PLOW

- Robust track plow moves material from spills and grade defects away from the track area for a consistent ride that limits tow-point movement
- Replaceable wear strips and durable backing ensure performance

PAVER AND SCREED COMPATIBILITY CHART

	SE50 V Vibratory Screed	SE50 VT Vibratory and Tamper Screed	SE60 V Vibratory Screed	SE60 V XW Extra-wide Vibratory Screed	SE60 VT XW Extra-wide Vibratory and Tamper Screed
AP500F Paver	●	Requires Tamper Ready Paver			
AP555F Paver	●	Requires Tamper Ready Paver			
AP600F Paver	●	Requires Tamper Ready Paver	●		
AP655F Paver	●	Requires Tamper Ready Paver	●	●	Requires Tamper Ready Paver
AP1000F Paver			●	●	Requires Tamper Ready Paver
AP1055F Paver			●	●	Requires Tamper Ready Paver

Note: Tamper ready pavers are equipped with additional hydraulics including, pump, valve, and hoses to support the tamper bar system.

OPTIONAL EQUIPMENT

- Air-ride Seat w/Heat
- All-Wheel Drive
- Auger and Mainframe Extensions
- Auxiliary Power Panel (2nd)
- Ballast (front bumper)
- Cat Grade and Slope Controls
- Decelerator Pedals
- Ecological Washdown System
- Feeder Sensor (mechanical or sonic)
- Friction Steering
- Hard Top Canopy
- Front Wheel Assist
- HID Lights
- Leveling Devices
- Lights (Working or Roading)
- Smooth/treadbar belt
- Oscillating Push Roller
- Power Folding Front Apron
- Power Mainframe Extensions
- Product Link
- Screed Extensions
- Tow-point Indicators (Upper)
- Track Plow
- Truck Hitch
- Umbrella
- Up-time Kit
- Warning Beacon
- Wide Width Paving Packages
- Windshield w/hard top canopy

AP500F SPECIFICATIONS

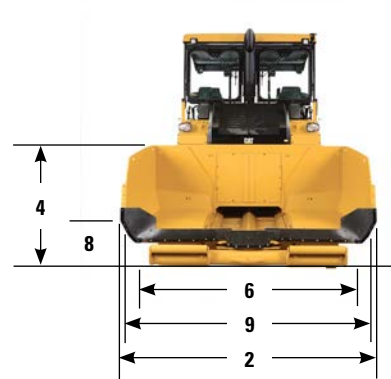
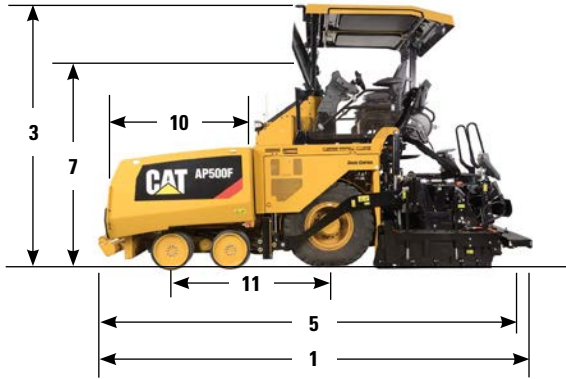

Dimensions

1	Operating length w/SE50 V, SE50 VT screeds	6291 mm	20' 7"
2	Operating width	3306 mm	10' 10"
3	Operating height, top of exhaust stack	3877 mm	12' 8"
4	Operating deck height	1780 mm	5' 10"
5	Transport length	6213 mm	20' 4"
6	Transport width		
	with SE50V, SE50 VT w/endgates	2762 mm	9' 1"
	with SE50V, SE50 VT w/endgates folded	2550 mm	8' 4"
7	Transport height - canopy retracted	3048 mm	10'
	Transport height - without canopy	2920 mm	9' 7"
8	Truck entry height - manual apron	510 mm	20"
	hydraulic apron	496 mm	19.5"
9	Truck entry width	3194 mm	10' 6"
10	Hopper length		
	with push-roller - minimum	2121 mm	6' 3"
	with push-roller - maximum	2320 mm	7' 7"
11	Wheelbase	2294 mm	7' 6"

Powertrain

Cat C4.4 ACERT™ Engine*	106 kW	144 hp (M)	142 hp (I)
* Two engine options are available in order to meet U.S. EPA Tier 4 Final/EU Stage IV emission standards or emissions equivalent to U.S. EPA Tier 3, EU Stage IIIA, and China Stage III.			
Number of Cylinders	4		
Engine speed - maximum/minimum	2200/1000 rpm		
Eco-mode	1650 rpm		
Screed heating - standard width (Quiet)	1300 rpm		
Screed heating - w/extensions (Quick)	1300 to 2200 rpm		
Speed ranges			
Paving	76 mpm	250 fpm	
With Tamper-bar screed	25 mpm	82 fpm	
Travel	16 km/hr	10 mph	
Inside Turning Radius	0.35 m	1.15 ft	

Weights

AP500F Paver only - shipping	12 970 kg	28,599 lb
AP500F Paver only - operating	13 161 kg	29,020 lb
<i>Operating weight includes full fuel tank and 75 kg (165 lb) operator.</i>		
SE50 V Screed only	3284 kg	7,239 lb
SE50 VT Screed only	3490 kg	7,695 lb

Paving Specifications

Standard paving range		
with SE50 V, SE50 VT	2.55 - 5.0 m	8' 4"-16' 4"
Maximum paving width		
with SE50 V, SE50 VT	6.5 m	21' 4"
Maximum paving depth	305 mm	12"

Capacities

Maximum throughput capacity	1168 tonnes/h	1,288 tph
Hopper capacity with tunnels	6.7 m ³	237 ft ³
Fuel tank	179 L	47 gal
DEF (Urea) capacity	19.1 L	5 gal
Engine oil	7 L	1.85 gal
Cooling system	30 L	7.9 gal
Hydraulic tank	107 L	28 gal

AP555F SPECIFICATIONS

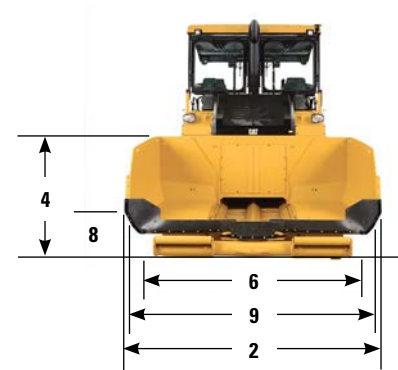
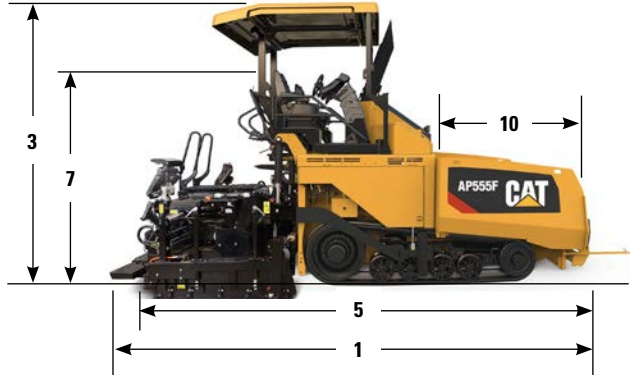

Dimensions

1	Operating length	6323 mm	20' 9"
2	Operating width	3306 mm	10' 10"
3	Operating height - top of exhaust stack	3888 mm	12' 9"
4	Operating deck height	1791 mm	5' 10"
5	Transport length with SE50 V, SE50 VT	6245 mm	20' 6"
6	Transport width		
	with SE50 w/endgates	2762 mm	9' 1"
	with SE50 w/endgates folded	2550 mm	8' 4"
7	Transport height - canopy retracted	3059 mm	10'
	Transport height - without canopy	2931 mm	9' 7"
8	Truck entry height - manual apron	531 mm	21"
	hydraulic apron	517 mm	20"
9	Truck entry width	3194 mm	10' 6"
10	Hopper length with push-roller		
	Minimum	2121 mm	6' 11"
	Maximum	2320 mm	7' 7"

Powertrain

Cat C4.4 ACERT™ Engine*	106 kW	144 hp (M)	142 hp (I)
* Two engine options are available in order to meet U.S. EPA Tier 4 Final/EU Stage IV emission standards or emissions equivalent to U.S. EPA Tier 3, EU Stage IIIA, and China Stage III.			
Number of Cylinders	4		
Engine speed - maximum/minimum	2200/1000 rpm		
Eco-mode	1650 rpm		
Screed heating - standard width (Quiet)	1300 rpm		
Screed heating - w/extensions (Quick)	1300 to 2200 rpm		
Speed ranges			
Paving	64 mpm	210 fpm	
With Tamper-bar screed	25 mpm	82 fpm	
Travel	11 km/hr	7 mph	

Weights

AP555F Paver only - shipping	13 609 kg	30,009 lb
AP555F Paver only - operating	13 800 kg	30,430 lb
<i>Operating weight includes full fuel tank and 75 kg (165 lb) operator.</i>		
SE50 V Screed only	3284 kg	7,239 lb
SE50 VT Screed only	3490 kg	7,695 lb

Paving Specifications

Standard paving range		
with SE50 V, SE50 VT	2.55 - 5.0 m	8' 4"-16' 4"
Maximum paving width		
with SE50 V,	6.5 m	21' 7"
with SE50 VT	7.5 m	24' 7"
Maximum paving depth	305 mm	12"

Capacities

Maximum throughput capacity	1168 tonnes/h	1,288 tph
Hopper capacity with tunnels	6.2 m ³	219 ft ³
Fuel tank	179 L	47 gal
DEF (Urea) capacity	19.1 L	5 gal
Engine oil	7 L	1.85 gal
Cooling system	30 L	7.9 gal
Hydraulic tank	107 L	28 gal

AP600F SPECIFICATIONS

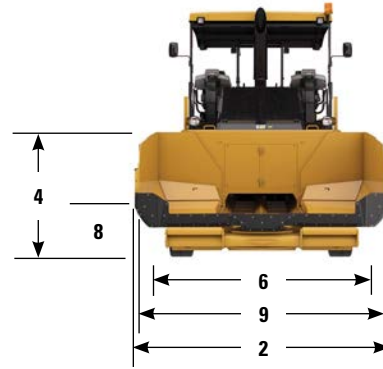
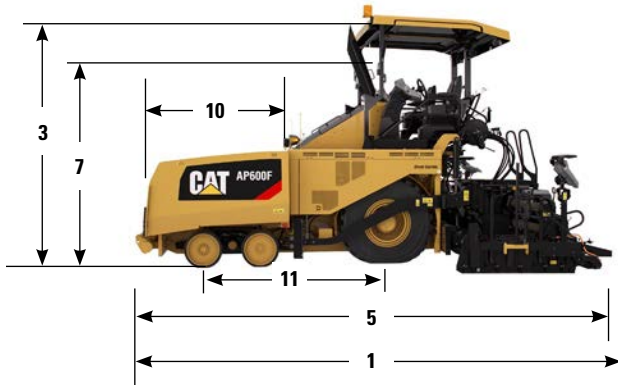

Dimensions

1 Operating length			
with SE50 V	6820 mm	22' 5"	
with SE50 VT	6820 mm	22' 5"	
with SE60 V	6825 mm	22' 5"	
2 Operating width	3306 mm	10' 10"	
3 Operating height			
with canopy, (top of beacon)	3914 mm	12' 10"	
without canopy	3802 mm	12' 4"	
4 Operating deck height	1850 mm	6' 1"	
5 Transport length	6720 mm	22' 1"	
6 Transport width			
with SE50-Series w/endgates	2762 mm	9' 1"	
with SE50-Series w/endgates folded	2550 mm	8' 4"	
with SE60 V w/endgates	3211 mm	10' 6"	
with SE60 V w/endgates folded	3000 mm	9' 10"	
7 Transport height - canopy retracted	3098 mm	10' 2"	
Transport height - without canopy	2997 mm	9' 10"	
8 Truck entry height - manual apron	477 mm	18"	
hydraulic apron	466 mm	18"	
9 Truck entry width	3194 mm	10' 6"	
10 Hopper length			
with push-roller - minimum	2215 mm	7' 3"	
with push-roller - maximum	2414 mm	7' 11"	
11 Wheelbase	2276 mm	9' 1"	

Powertrain

Cat C4.4 ACERT™ Engine*	129 kW	175 hp (M)	173 hp (I)
* Engine meets U.S. EPA Tier 4 Final/E.U. Stage IV emission standards.			
Cat C7.1 Engine**	151 kW	205 hp (M)	202 hp (I)
** Engine meets emissions equivalent to U.S. EPA Tier 3, EU Stage IIIA, and China Stage III.			
Number of Cylinders - C4.4	4		
Number of Cylinders - C7.1	6		
Engine speed - maximum/minimum	2200/1000 rpm		
Eco-mode	1650 rpm		
Screed heating - standard width (Quiet)	1300 rpm		
Screed heating - w/extensions (Quick)	1300 to 2200 rpm		
Speed ranges			
Paving	76 mpm	250 fpm	
With Tamper-bar screed	25 mpm	82 fpm	
Travel	16 km/hr	10 mph	
Italian Road Homologation	14.9 km/hr	9.3 mph	
Inside Turning Radius	1.5 m	4.5 ft	

Weights

AP600F Paver only - shipping	13 558 kg	29,891 lb
AP600F Paver only - operating	13 845 kg	30,522 lb

Operating weight includes full fuel tank and 75 kg (165 lb) operator.

SE50 V Screed only	3284 kg	7,239 lb
SE50 VT Screed only	3490 kg	7,695 lb
SE60 V Screed only	3400 kg	7,495 lb

Paving Specifications

Standard paving range		
with SE50 V, SE50 VT	2.55 - 5.0 m	8' 4" - 16' 4"
with SE60 V	3.0 - 6.0 m	9' 10" - 19' 6"
Maximum paving width		
with SE50 V	6.5 m	21' 4"
with SE50 VT	8.0 m	26' 4"
with SE60 V	7.65 m	25'
Maximum paving depth	305 mm	12"

Capacities

Maximum throughput capacity	1300 tonnes/h	1,433 tph
Hopper capacity with tunnels	7.1 m ³	250 ft ³
Fuel tank	278 L	73 gal
DEF (Urea) capacity - Cat 4.4 engine only	19.1 L	5 gal
Engine oil - Cat 4.4 engine	13.5 L	3.6 gal
Cat 7.1 engine	15.5 L	4.1 gal
Cooling system - Cat C4.4 engine	31 L	8 gal
Cat 7.1 engine	37 L	9.8 gal
Hydraulic tank	219 L	58 gal

AP655F MOBIL-TRAC SPECIFICATIONS

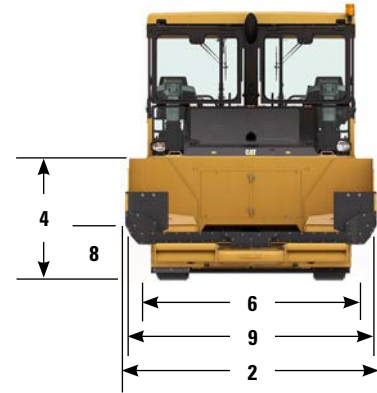
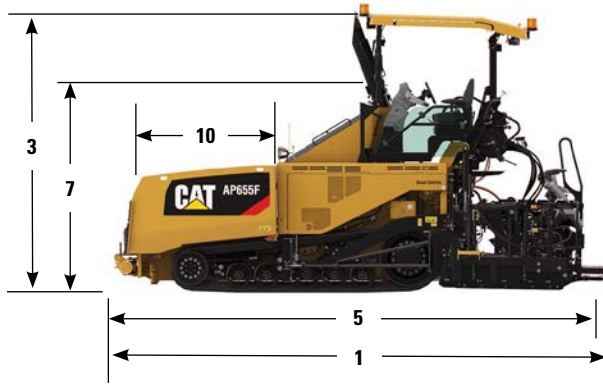

Dimensions

1 Operating length		
with SE50 V	6829 mm	22' 5"
with SE50 VT	6829 mm	22' 5"
with SE60 V	6829 mm	22' 5"
with SE60 V XW, SE60 VT XW	7034 mm	23' 1"
2 Operating width	3306 mm	10' 10"
3 Operating height		
with canopy (top of exhaust)	3889 mm	12' 9"
without canopy	3777 mm	12' 4"
4 Operating deck height	1792 mm	5' 10"
5 Transport length		
with SE50 V, SE50 VT	6720 mm	22' 1"
with SE60 V XW, SE60 VT XW	6910 mm	22' 8"
6 Transport width		
with SE50 w/endgates	2762 mm	9' 1"
with SE50 w/endgates folded	2550 mm	8' 4"
with SE60 w/endgates	3211 mm	10' 6"
with SE60 w/endgates folded	3000 mm	9' 10"
7 Transport height - canopy retracted	3056 mm	10'
Transport height - without canopy	2929 mm	9' 7"
8 Truck entry height - manual apron	529 mm	21"
hydraulic apron	521 mm	21"
9 Truck entry width	3194 mm	10' 6"
10 Hopper length with push-roller		
Minimum	2215 mm	7' 3"
Maximum	2414 mm	7' 11"

Powertrain

Cat C4.4 ACERT™ Engine*	129 kW	175 hp (M)	173 hp (I)
* Engine meets U.S. EPA Tier 4 Final/E.U. Stage IV emission standards.			
Cat C7.1 Engine**	151 kW	205 hp (M)	202 hp (I)
** Engine meets emissions equivalent to U.S. EPA Tier 3, EU Stage IIIA, and China Stage III.			
Number of Cylinders - C4.4	4		
Number of Cylinders - C7.1	6		
Engine speed - maximum/minimum	2200/1000 rpm		
Eco-mode	1650 rpm		
Screed heating - standard width (Quiet)	1300 rpm		
Screed heating - w/extensions (Quick)	1300 to 2200 rpm		
Speed ranges			
Paving	64 mpm	210 fpm	
With Tamper-bar screed	25 mpm	82 fpm	
Travel	14.5 km/hr	9 mph	

Weights

AP655F Paver only - shipping	15 297 kg	33,730 lb
AP655F Paver only - operating	15 584 kg	34,356 lb

Operating weight includes full fuel tank and 75 kg (165 lb) operator.

SE50 V Screed only	3284 kg	7,239 lb
SE50 VT Screed only	3490 kg	7,695 lb
SE60 V Screed only	3400 kg	7,495 lb
SE60 V XW Screed*** only	4070 kg	8,973 lb
SE60 VT XW Screed*** only	4532 kg	9,991 lb

*** Not available on the AP655F for the U.S. market.

Paving Specifications

Standard paving range		
with SE50 V, SE50 VT	2.55 - 5.0 m	8' 4"-16' 4"
with SE60 V, SE60 V XW, SE60 VT XW	3.0 - 6.0 m	9' 10" - 19' 6"
Maximum paving width		
with SE50 V	6.5 m	21' 4"
with SE50 VT	8.0 m	26' 4"
with SE60 V	7.65 m	25'
with SE60 V XW, SE60 VT XW	10.0 m	33'
Maximum paving depth	305 mm	12"

Capacities

Maximum throughput capacity	1300 tonnes/h	1,433 tph
Hopper capacity with tunnels	7.1 m ³	250 ft ³
Fuel tank	278 L	73 gal
DEF (Urea) capacity - Cat 4.4 engine only	19.1 L	5 gal
Engine oil - Cat 4.4 engine	13.5 L	3.6 gal
Cat 7.1 engine	15.5 L	4.1 gal
Cooling system - Cat C4.4 engine	31 L	8 gal
Cat 7.1 engine	37 L	9.8 gal
Hydraulic tank	219 L	58 gal

AP655F STEEL TRACK SPECIFICATIONS

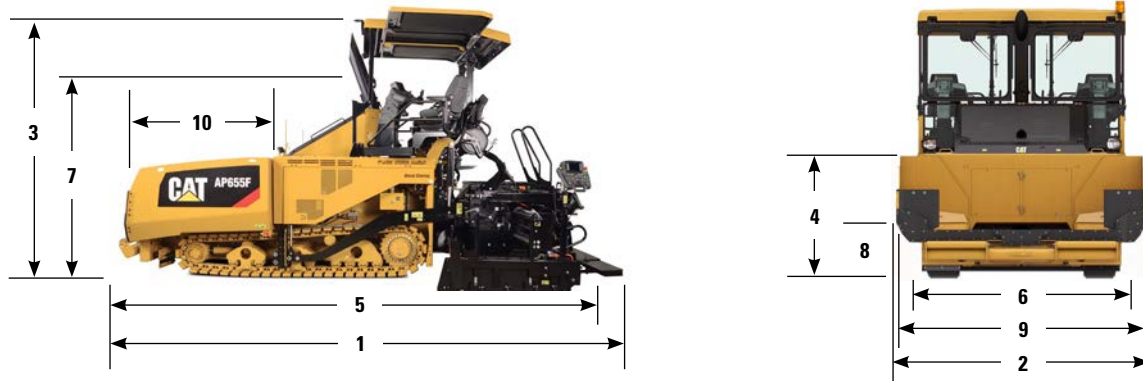

Dimensions

1 Operating length		
with SE50 V	6829 mm	22' 5"
with SE50 VT	6829 mm	22' 5"
with SE60 V	6829 mm	22' 5"
with SE60 V XW, SE60 VT XW	7034 mm	23' 1"
2 Operating width	3306 mm	10' 10"
3 Operating height		
with canopy (top of exhaust)	3873 mm	12' 8"
without canopy	3761 mm	12' 1"
4 Operating deck height	1776 mm	5' 10"
5 Transport length		
with SE50 V, SE50 VT	6720 mm	22' 1"
with SE60 V XW, SE60 VT XW	6910 mm	22' 8"
6 Transport width		
with SE50 w/endgates	2762 mm	9' 1"
with SE50 w/endgates folded	2550 mm	8' 4"
with SE60 w/endgates	3211 mm	10' 6"
with SE60 w/endgates folded	3000 mm	9' 10"
7 Transport height - canopy retracted	3040 mm	10'
Transport height - without canopy	2914 mm	9' 6"
8 Truck entry height - manual apron	509 mm	20"
hydraulic apron	498 mm	19"
9 Truck entry width	3194 mm	10' 6"
10 Hopper length with push-roller		
Minimum	2215 mm	7' 3"
Maximum	2414 mm	7' 11"

Powertrain

Cat C4.4 ACERT™ Engine*	129 kW	175 hp (M)	173 hp (I)
* Engine meets U.S. EPA Tier 4 Final/E.U. Stage IV emission standards.			
Cat C7.1 Engine**	151 kW	205 hp (M)	202 hp (I)
** Engine meets emissions equivalent to U.S. EPA Tier 3, EU Stage IIIA, and China Stage III.			
Number of Cylinders - C4.4	4		
Number of Cylinders - C7.1	6		
Engine speed - maximum/minimum	2200/1000 rpm		
Eco-mode	1650 rpm		
Screed heating - standard width (Quiet)	1300 rpm		
Screed heating - w/extensions (Quick)	1300 to 2200 rpm		
Speed ranges			
Paving	49 mpm	160 fpm	
With Tamper-bar screed	25 mpm	82 fpm	
Travel	6.5 km/hr	4 mph	

Weights

AP655F Paver only - shipping	15 297 kg	33,730 lb
AP655F Paver only - operating	16 043 kg	35,368 lb
<i>Operating weight includes full fuel tank and 75 kg (165 lb) operator.</i>		
SE50 V Screed only	3284 kg	7,239 lb
SE50 VT Screed only	3490 kg	7,695 lb
SE60 V Screed only	3400 kg	7,495 lb
SE60 V XW Screed*** only	4070 kg	8,973 lb
SE60 VT XW Screed*** only	4532 kg	9,991 lb

*** Not available on the AP655F for the U.S. market.

Paving Specifications

Standard paving range		
with SE50 V, VT	2.55 - 5.0 m	8' 4"-16' 4"
with SE60 V, SE60 V XW, SE60 VT XW	3.0 - 6.0 m	9' 10" - 19' 6"
Maximum paving width		
with SE50 V	6.5 m	21' 4"
with SE50 VT	8.0 m	26' 4"
with SE60 V	7.65 m	25'
with SE60 V XW, SE60 VT XW	10.0 m	33'
Maximum paving depth	305 mm	12"

Capacities

Maximum throughput capacity	1300 tonnes/h	1,433 tph
Hopper capacity with tunnels	7.1 m³	250 ft³
Fuel tank	278 L	73 gal
DEF (Urea) capacity - Cat 4.4 engine only	19.1 L	5 gal
Engine oil - Cat 4.4 engine	13.5 L	3.6 gal
Cat 7.1 engine	15.5 L	4.1 gal
Cooling system - Cat C4.4 engine	31 L	8 gal
Cat 7.1 engine	37 L	9.8 gal
Hydraulic tank	219 L	58 gal

AP1000F SPECIFICATIONS

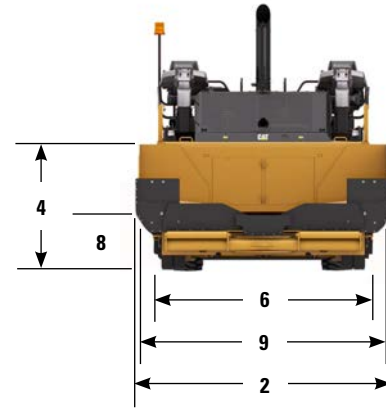
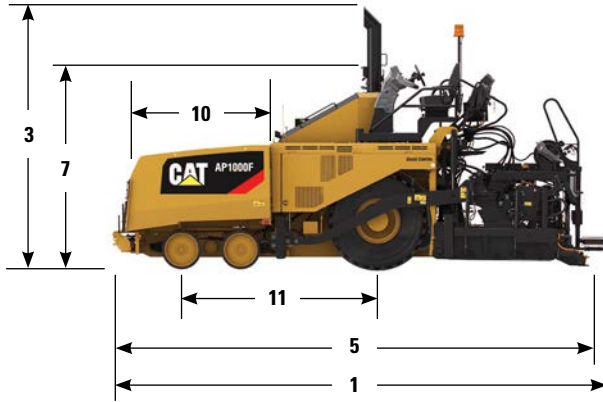

Dimensions

1 Operating length		
with SE60 V	6860 mm	22' 6"
with SE60 V XW, SE60 VT XW	7050 mm	23' 2"
without screed and canopy	5563 mm	18' 3"
2 Operating width - standard entry hopper	3350 mm	11' 0"
Operating width - low entry hopper	3604 mm	11' 10"
3 Operating height with canopy, (top of beacon)	4000 mm	13' 1"
Operating height without canopy	3715 mm	12' 2"
4 Operating deck height	1791 mm	5' 11"
5 Transport length with SE60 V	6720 mm	22' 1"
Transport length with SE60 V XW, SE60 VT XW	6910 mm	22' 8"
6 Transport width with endgates	3211 mm	10' 6"
Transport width - endgates folded	3000 mm	9' 10"
7 Transport height - canopy retracted	3100 mm	10' 2"
Transport height - without canopy	3000 mm	9' 10"
8 Truck entry height with standard entry hopper		
Manual apron	572 mm	22.5"
Hydraulic apron	616 mm	24"
Truck entry height with low entry hopper		
Manual apron	529 mm	21"
Hydraulic apron	587 mm	23"
9 Truck entry width - standard entry hopper	3224 mm	10' 7"
Truck entry width - low entry hopper	3490 mm	11' 6"
10 Hopper length with push-roller		
Minimum	2215 mm	7' 3"
Maximum	2414 mm	7' 11"
11 Wheel base	2776 mm	9' 1"

Powertrain

Cat C7.1 ACERT Engine	168 kW	225 hp
Engine meets U.S. EPA Tier 4 Final/E.U. Stage IV emission standards.		
Number of cylinders	6	
Engine speed - maximum/minimum	2200/1000 rpm	
Eco-mode	1650 rpm	
Screed heating - standard width (Quiet)	1300 rpm	
Screed heating - w/extensions (Quick)	1300 to 2200 rpm	
Speeds Ranges		
Paving w/vibratory screed	76 mpm	250 fpm
Paving w/tamper-bar screed	25 mpm	82 fpm
Travel	19.9 km/hr	12 mph
Inside Turning Radius	0.5 m	1.5 ft

Weights

AP1000F (Paver only - shipping)	15 526 kg	34,228 lb
AP1000F (Paver only - operating)	15 794 kg	34,820 lb

Operating weight includes full fuel tank and 75 kg (165 lb) operator.

SE60 V Screed only	3400 kg	7,495 lb
SE60 V XW Screed only	4070 kg	8,973 lb
SE60 VT XW Screed only	4532 kg	9,991 lb

Paving Specifications

Standard paving range	3.0 - 6.0 m	9' 10" - 19' 6"
Max. paving width w/extensions	7.65 m	25'
Maximum paving depth	305 mm	12"

Capacities

Maximum throughput capacity	1602 tonnes/h	1,766 tph
Hopper capacity with tunnels		
Standard entry hopper	7.6 m ³	267 ft ³
Low entry hopper	8.1 m ³	286 ft ³
Fuel tank	348 L	92 gal
DEF (Urea)	19.1 L	5 gal
Cooling system	45.4 L	12 gal
Engine oil	16 L	4.2 gal
Hydraulic tank	219 L	58 gal

AP1055F SPECIFICATIONS

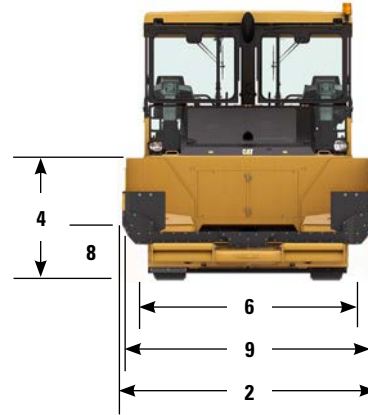
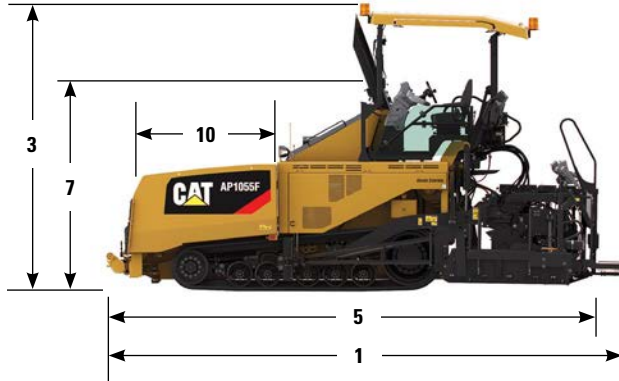

Dimensions

1 Operating length		
with SE60 V	6840 mm	22' 5"
with SE60 V XW, SE60 VT XW	7034 mm	23' 1"
without screed	5609 mm	18' 5"
2 Operating width - standard entry hopper	3336 mm	10' 11"
Operating width - low entry hopper	3604 mm	11' 10"
3 Operating height with canopy, (top of beacon)	3996 mm	13' 1"
Operating height without canopy	3715 mm	12' 2"
4 Operating deck height	1791 mm	5' 11"
5 Transport length with SE60 V	6710 mm	22'
Transport length with SE60 V XW, SE60 VT XW	6900 mm	22' 8"
6 Transport width - with endgates	3211 mm	10' 6"
Transport width - endgates folded	3000 mm	9' 10"
7 Transport height - canopy retracted	3056 mm	10'
Transport height - without canopy	2929 mm	9' 5"
8 Truck entry height with standard entry hopper		
Manual apron	570 mm	22.5"
Hydraulic apron	616 mm	24"
Truck entry height with low entry hopper		
Manual apron	521 mm	20.5"
Hydraulic apron	587 mm	23"
9 Truck entry width - standard entry hopper	3224 mm	10' 7"
Truck entry width - low entry hopper	3490 mm	11' 6"
10 Hopper length with push-roller		
Minimum	2215 mm	7' 3"
Maximum	2414 mm	7' 11"

Powertrain

Cat C7.1 ACERT Engine*	168 kW	225 hp
* Engine meets U.S. EPA Tier 4 Final/EU Stage IV emission standards.		
Cat C7.1 Engine**	186 kW	249 hp
** Engine meets emissions equivalent to U.S. EPA Tier 3 and EU Stage IIIA requirements.		
Number of cylinders	6	
Engine speed - maximum/minimum	2200/1100 rpm	
Eco-mode	1650 rpm	
Screed heating - standard width (Quiet)	1300 rpm	
Screed heating - w/extensions (Quick)	1300 to 2200 rpm	
Speed Ranges		
Paving w/vibratory screed	64 mpm	210 fpm
Paving w/tamper-bar screed	25 mpm	82 fpm
Travel	14.5 km/hr	9 mph

Weights

Australia, U.S. and Canada

AP1055F (Paver only - shipping)	16 691 kg	36,804 lb
AP1055F (Paver only - operating)	17 031 kg	37,553 lb

China, Middle-East, Russia, South America

AP1055F (Paver only - shipping)	17 015 kg	37,518 lb
AP1055F (Paver only - operating)	17 355 kg	38,261 lb

Operating weight includes full fuel tank and 75 kg (165 lb) operator.

SE60 V Screed only	3400 kg	7,495 lb
SE60 V XW Screed only	4070 kg	8,973 lb
SE60 VT XW Screed only	4532 kg	9,991 lb

Paving Specifications

Standard paving range	3.0 - 6.0 m	9' 10" - 19' 6"
SE60 V max. paving width w/extensions	7.65 m	25'
SE60 V XW max. paving width w/extensions	10.0 m	33'
SE60 VT XW max. paving width w/extensions	10.0 m	33'
Maximum paving depth	305 mm	12"

Capacities

Maximum throughput capacity	1602 tonnes/h	1,766 tph
Hopper capacity with tunnels		
Standard entry hopper	7.6 m ³	267 ft ³
Low entry hopper	8.1 m ³	286 ft ³
Fuel tank	348 L	92 gal
DEF (Urea)	19.1 L	5 gal
Cooling system	45.4 L	12 gal
Engine oil	16 L	4.2 gal
Hydraulic tank	219 L	58 gal

CAT SCREEDS

SCREED HEAT TECHNOLOGY

- Exclusive zone monitoring allows heating to continue in the event of a temperature sensor failure
- Exclusive screed heating system monitors elements for failure conditions, eliminates unnecessary replacement
- Warning/failure indicators delivered through the LCD displays
- Heated end gate option improves material flow and mat texture

INCREASED DURABILITY, LOWER COSTS

- Million cycle keypad switches ensure reliability
- Exclusive screed plate material provides long-term durability
- Oil-bath vibratory pods deliver exceptional longevity
- Larger extender support tube assembly increases rigidity for better mat quality

EASY ADJUSTMENTS

- Feeder system ratio adjustment capability from the screed, *previously adjusted from the tractor only*
- Standard power adjustment for extender height, slope and crown, allows for on-the-go adjustments at standard and maximum paving widths
- Exclusive extender angle of attack adjustments (XW-Series)
- Trailing edge screed plate adjusters help maintain even wear across the entire length for optimal life
- Center pivot pin, allows for on-the-go two-bolt adjustment to the extender for improved texture control
- Exclusive tow-point design optimizes screed flotation

BETTER EFFICIENCY

- Heating elements slide-out for easy replacement
- Machined screed frames simplify screed plate replacement and leveling
- Innovative hooking system utilizes extender slope to attach wide-width paving packages; eliminates other lifting device needs



We were on our way to reaching density targets even before the roller went to work!

– Cat Paving Contractor

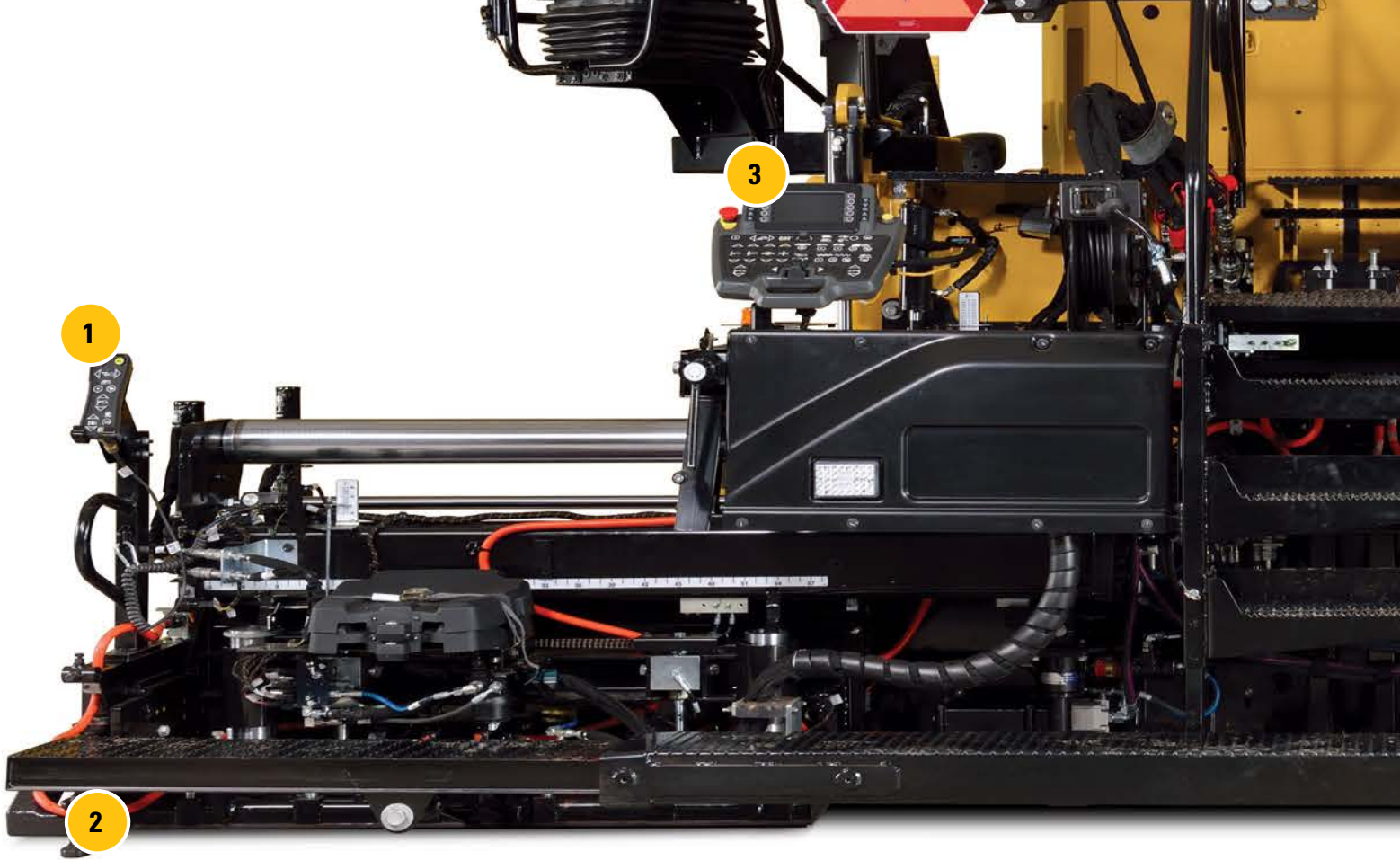

- | | |
|---------------------------------------------------|----------------------------------|
| 1. Remote Pendant | 6. Quick-Change Heating Elements |
| 2. Folding End Gate (Option) | 7. Free-Floating Tow-Point |
| 3. Integrated Cat Grade Control | 8. Generator Activation |
| 4. On-the-Go Angle of Attack Adjuster (XW-Series) | 9. Temperature Selection |
| 5. Trailing Edge Screed Plate Adjusters | 10. Temperature Zone Monitoring |

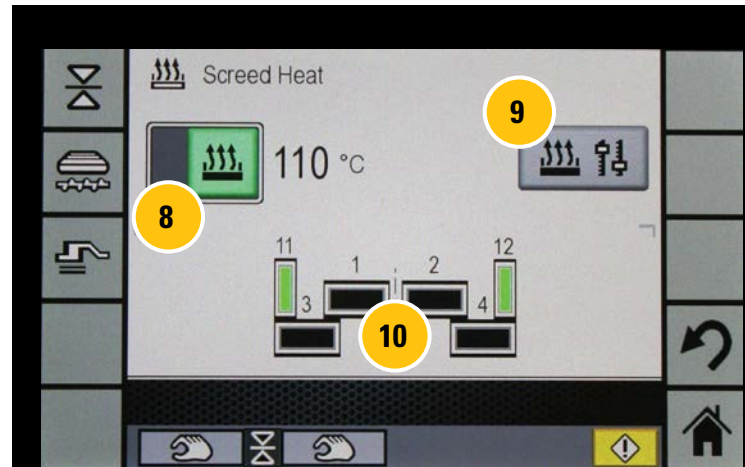
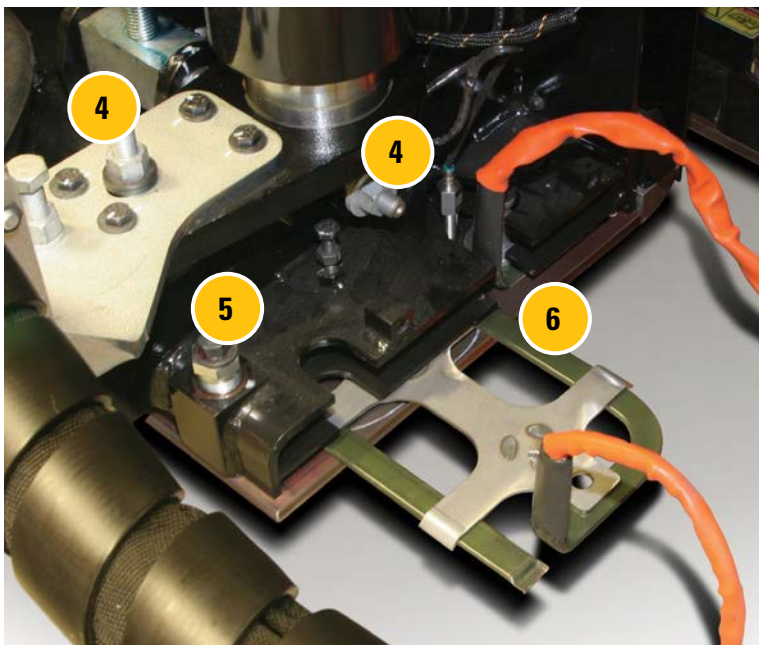



TAMPER BARS AND VIBRATORY SCREED PLATES

MAXIMIZE DENSITY BEHIND THE SCREED

- | | |
|-------------------------------|-----------------------------------------|
| 1. Spring-Loaded End Gates | 7. Tamper Bar |
| 2. Heated End Gate (optional) | 8. Replaceable Wear Plate (Bolt-on) |
| 3. Screed Controls | 9. Vibratory Drive (Oil-Bath) |
| 4. Standard Power Crown | 10. Quick-Change Heating Element |
| 5. Tamper Bar Eccentric Drive | 11. Single Main Screed Plate |
| 6. Tamper Bar Heating Element | 12. Threaded-Bolt Screed Plate Adjuster |

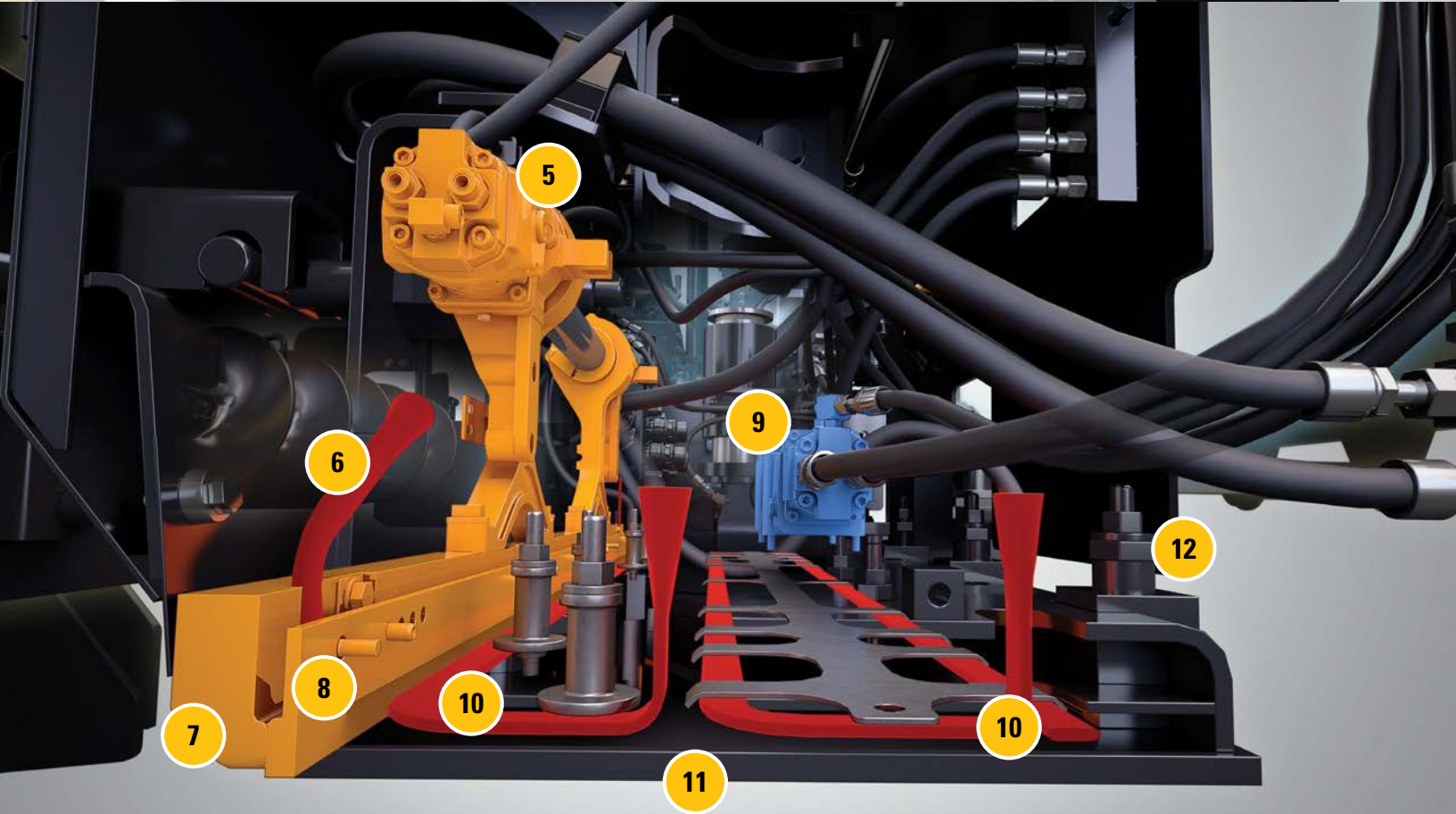



TOP FEATURES

1. Cat Grade Control Indicators
2. Soft-Key Adjustments
3. Conveyor Ratio Control Adjustment (Touch-screen)
4. Lockout Key
5. 2-Speed Extender Control
6. Proportional Extender Switch

IMPROVED CONTROL BETTER DISPLAYS

SWITCHES, PENDENTS, TOUCHSCREENS
BENEFIT SCREED OPERATORS

The screed extenders offer proportional control and two speed ranges for excellent performance.

SCREED CONSOLES

- Switches are sealed and serviceable; meets IP67 common water submergence rating
- 2-speed, proportional extender control provides efficient performance when changing paving widths
- Configurable lockout feature prevents unintentional adjustment
- Additional material feed controls include pause and reverse for both conveyors and augers; provides greater control when utilizing the four sensor feeder system

LCD DISPLAY

- Multiple language options
- Colorful graphics for easy viewing day or night
- Touch-screen access to preferred settings and adjustments
- Store preferences for multiple operators

Innovative Functions

- Integrated Cat Grade Control
- Ratio control of conveyors now available from the screed consoles, previously only available from the tractor
Note: Mix height adjustment is available from the tractor, previously only available from the screed
- Easy access to service code information
- Activate screed heat, auxiliary power, fumes ventilation, machine washdown, etc.
- Monitor heating zones

REMOTE PENDENT CONTROL

- Extender in/out
- Feeder system pause or manual override
- Tow-point height raise/lower
- Lockout feature prevents unintentional adjustment



SE50 V SCREED

VIBRATORY SCREED



APPLICATIONS

- Highways
- Overlays
- Parking lots
- Rural roads
- Streets
- Variable width paving

SCREED OVERVIEW

The SE50 V vibratory screed utilizes rear-mounted extenders and fast heating screed plates, making it a perfect fit for parking areas, business developments and other applications that require variable width paving. The low profile design enables good visibility for efficient performance.

HIGHLIGHTS

- Standard extendable paving range of 2.55 m - 5.0 m (8' 4" - 16' 4")
- 15 minute heat up time at standard width
- Cat Grade Control integrated into each screed and tractor console
- Ratio adjustment capability of the conveyors from the screed
- Proportional extender control with two speed ranges
- Quick change heating elements
- Remote pendant located on the extenders
- Threaded bolt screed plate adjusters simplifies leveling

SPECIFICATIONS

Weight	3284 kg	7,239 lb
Standard paving range	2.55 - 5.0 m	8' 4" - 16' 4"
Maximum paving width	6.5 m	21' 4"
Maximum paving depth	305 mm	12"
Extender height range	-20 mm to +50 mm	
Crown range	-4% to +10% (total)	
Extender slope range	-3% to +10%	
Screed plate width (front to back)	407 mm	16"
Screed plate vibration range	0 - 3000 vpm	

SE50 VT SCREED

TAMPER BAR SCREED



APPLICATIONS

- Roller Compacted Concrete
- Airport projects
- Highways
- Interstates
- Mainline applications
- Overlays
- Rural roads
- Urban streets

SCREED OVERVIEW

The SE50 VT is equipped with tamper-bars and vibration that can be easily adjusted to help achieve quality results. The rigid frame design provides excellent stability making it a perfect fit for airports, interstates, highways and other medium to high-production job sites.

HIGHLIGHTS

- Standard extendable paving range of 2.55 m - 5.0 m (8' 4" - 16' 4")
- 15 minute heat up time at standard width
- Cat Grade Control integrated into each screed and tractor console
- Proportional extender control with two speed ranges
- Quick change heating elements
- Remote pendent located on the extenders
- Threaded bolt screed plate adjusters simplifies leveling

SPECIFICATIONS

Weight	3490 kg	7,695 lb
Standard paving range	2.55 - 5.0 m	8' 4" - 16' 4"
Maximum paving width	8.0 m	26' 4"
Maximum paving depth	305 mm	12"
Extender height range	-20 mm to +50 mm	
Crown range	-2% to +5% (per side)	
Extender slope range	-3% to +2%	
Screed plate width (front to back)	324 mm	12.75"
Screed plate vibration range	0 - 3000 rpm	
Tamper-bar speed range	700 - 1800 rpm	
Tamper-bar stroke (amplitude)	2, 4, 7 mm	0.08", 0.16", 0.28"

SE60 V SCREED

VIBRATORY SCREED



APPLICATIONS

- Airport projects
- Highways
- Interstates
- Mainline applications
- Overlays
- Rural roads
- Urban streets

SCREED OVERVIEW

The SE60 V vibratory screed is equipped with rear-mounted extenders and fast heating screed plates, making it a perfect fit for parking areas, business developments and other applications that require variable width paving. The low profile design enables good visibility for efficient performance.

HIGHLIGHTS

- Standard extendable paving range of 3.0 m - 6.0 m (9' 10" - 19' 6") with
- 15 minute heat up time at standard width
- Cat Grade Control integrated into each screed and tractor console
- Proportional extender control with two speed ranges
- Quick change heating elements
- Remote pendant located on the extenders
- Threaded bolt screed plate adjusters simplifies leveling

SPECIFICATIONS

Weight	3400 kg	7,495 lb
Standard paving range	3.0 - 6.0 m	9' 10" - 19' 6"
Maximum paving width	7.65 m	25'
Maximum paving depth	305 mm	12"
Extender height range	-20 mm to +50 mm	
Crown range	-4% to +10% (total)	
Extender slope range	-4% to +10%	
Screed plate width (front to back)	407 mm	16"
Screed plate vibration range	0 - 3000 vpm	

SE60 V XW SCREED

VIBRATORY SCREED



APPLICATIONS

- Wide-width applications
- Airport projects
- Highways
- Interstates
- Mainline applications
- Overlays
- Rural roads
- Urban streets

SCREED OVERVIEW

The SE60 V XW is equipped with vibratory screed plates and can be easily adjusted to achieve quality results. The rigid frame design provides excellent stability making it a perfect fit for airports, interstates, highways, and other high-production job sites.

HIGHLIGHTS

- Maximum paving width w/extensions is 10.0 m (33')
- Heat-up time in as little as 25 minutes at 10.0 m (33')
- Cat Grade Control integrated into each screed and tractor console
- Proportional extender control with two speed ranges
- Quick change heating elements
- Remote pendent located on the extenders
- Threaded bolt screed plate adjusters simplifies leveling

SPECIFICATIONS

Weight	4070 kg	8,973 lb
Standard paving range	3.0 - 6.0 m	9' 10" - 19' 6"
Maximum paving width	10.0 m	33'
Maximum paving depth	305 mm	12"
Extender height range	-20 mm to +50 mm	
Crown range	-4% to +10%	
Extender slope range	-3% to +10%	
Screed plate width (front to back)	407 mm	16"
Screed plate vibration range:	0 - 3000 rpm	

SE60 VT XW SCREED

TAMPER-BAR SCREED



APPLICATIONS

- Wide-width applications
- Roller Compacted Concrete
- Airport projects
- Highways
- Interstates
- Mainline paving
- Overlays
- Rural roads
- Urban streets

SCREED OVERVIEW

The SE60 VT XW is equipped with tamper-bars and vibration that can be easily adjusted to help achieve quality results. The rigid frame design provides excellent stability making it a perfect fit for airports, interstates, highways, and other high-production job sites.

HIGHLIGHTS

- Maximum paving width w/extensions 10.0 m (33')
- Heat-up time in as little as 25 minutes at 10.0 m (33')
- Equipped with tamper bars and vibratory screed plates
- Cat Grade Control integrated into each screed and tractor console
- Proportional extender control with two speed ranges
- Quick change heating elements
- Remote pendants located on the extenders
- Threaded bolt screed plate adjusters simplifies leveling

SPECIFICATIONS

Weight	4532 kg	9,991 lb
Standard paving range	3.0 - 6.0 m	9' 10" - 19' 6"
Maximum paving width	10.0 m	33'
Maximum paving depth	305 mm	12"
Extender height range	-20 mm to +50 mm	
Crown range	-2% to +5% (per side)	
Extender slope range	-3% to +5%	
Screed plate width (front to back)	407 mm	16"
Screed plate vibration range	0 - 3000 rpm	
Tamper-bar speed range	700 - 1800 rpm	
Tamper-bar stroke (amplitude)	2, 4, 7 mm	0.08", 0.16", 0.28"

WIDE-WIDTH PAVING PACKAGES

POWER ADJUSTMENT

- Exclusive power controls simplify adjustment across the entire 10.0 m (33') paving width for better mat texture and quality
 - Crown Range (-2% to +5%)
 - Slope Range
 - SE50 V (-3% to +10%)
 - SE60 V (-4% to +10%)
 - SE60 V XW (-3% to +10%)
 - SE60 VT XW (-3% to +5%)
 - Extender Height (-20 mm to +50 mm)
- * Note: The SE50 VT utilizes manual control for extender slope.*

EXCLUSIVE FASTENING SYSTEM

- Screed extensions can be attached utilizing power slope on the extender
- Eliminates additional lifting device

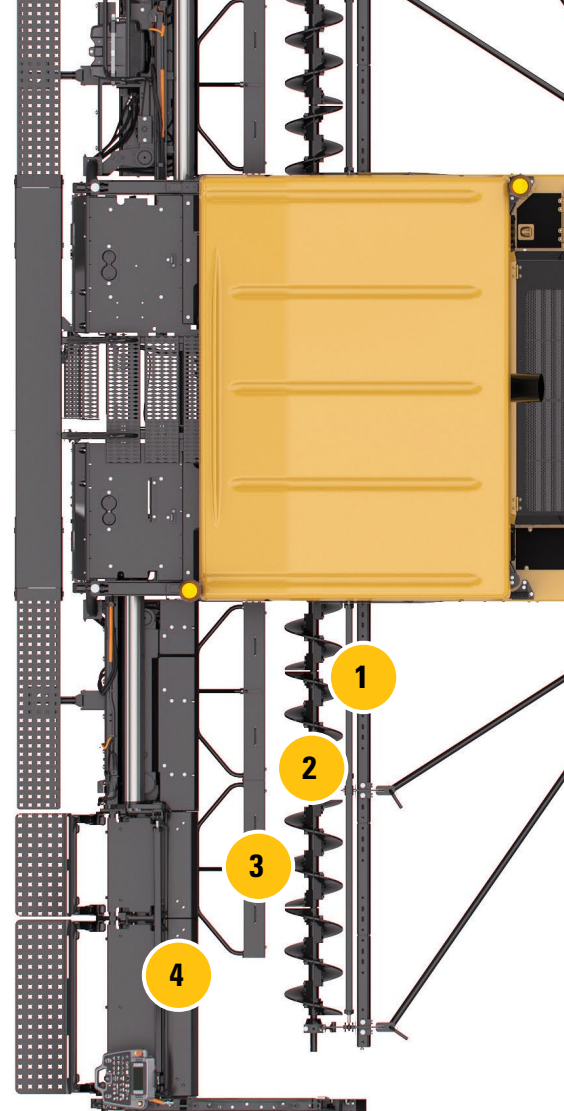

1. Mainframe Extensions
2. Auger Extensions
3. Strike-offs
4. Screed Extensions

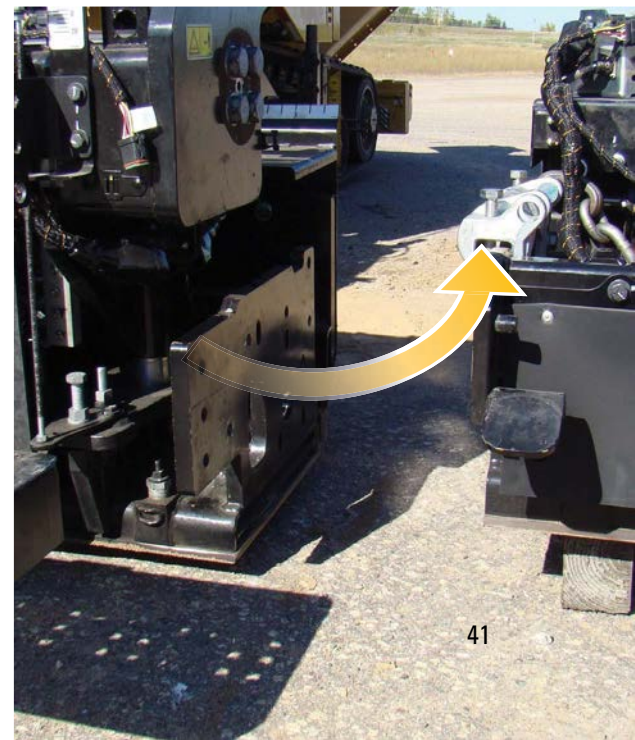

SCREED EXTENSIONS

SE50-SERIES

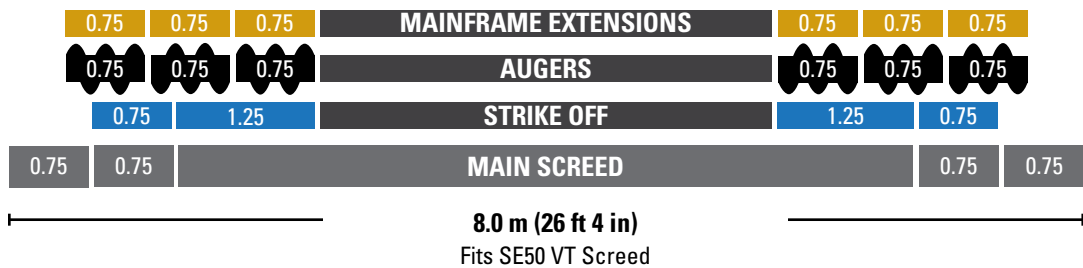
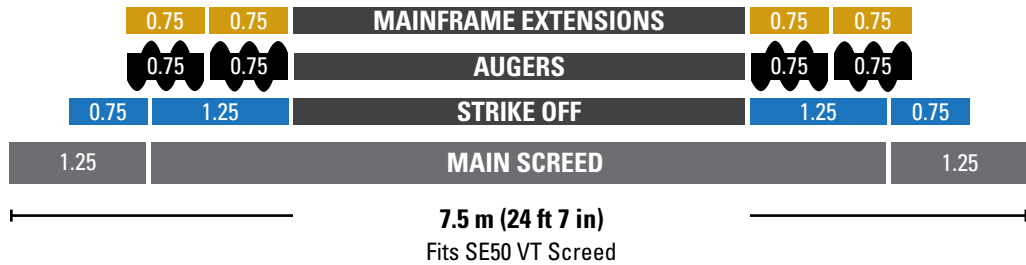
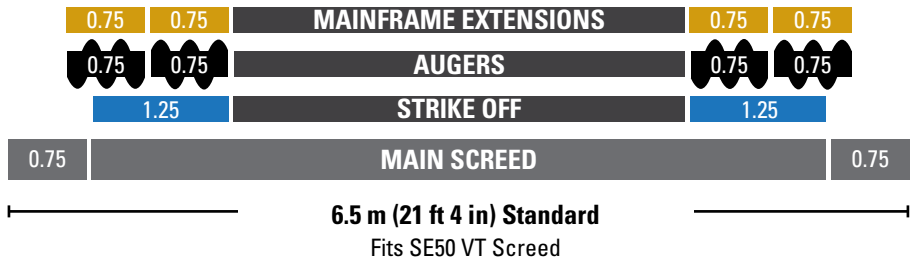
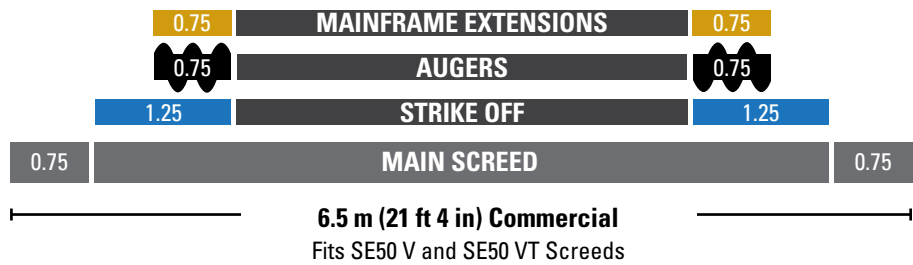
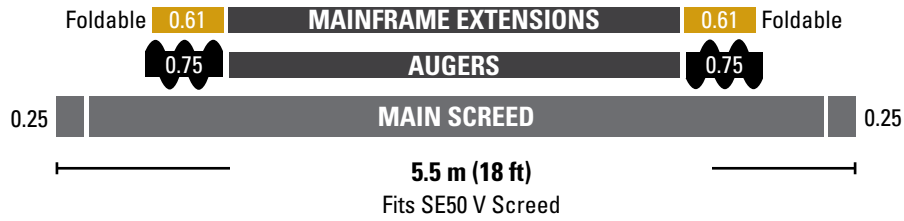

SCREED EXTENSIONS

SE60-SERIES

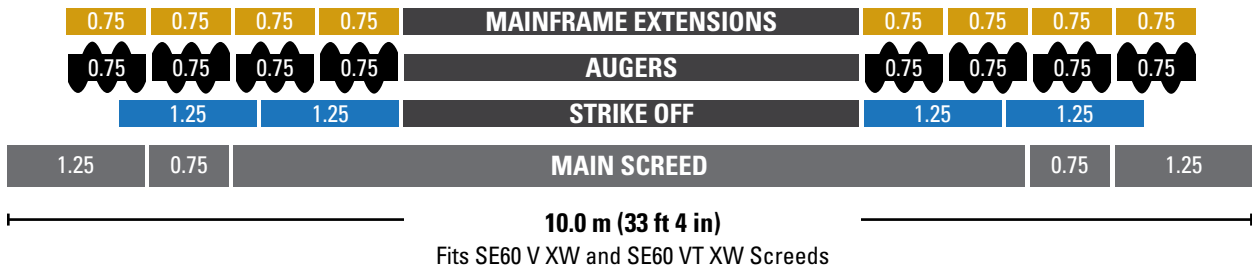
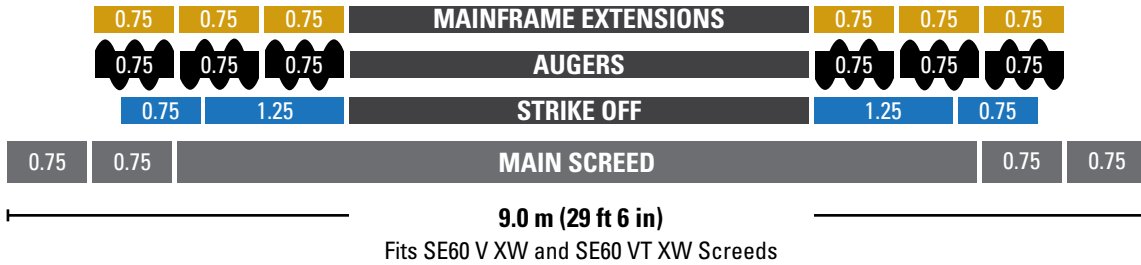
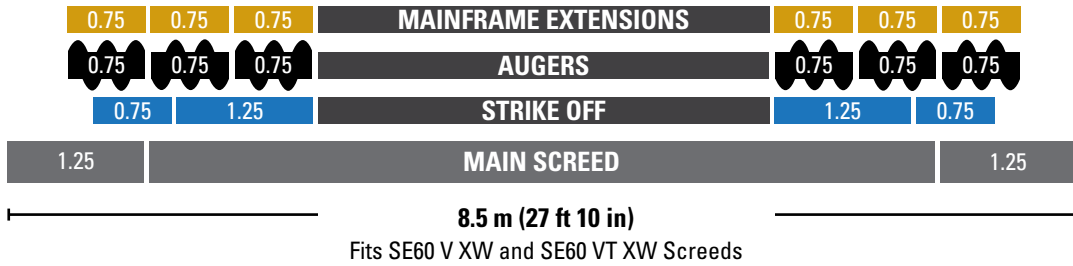
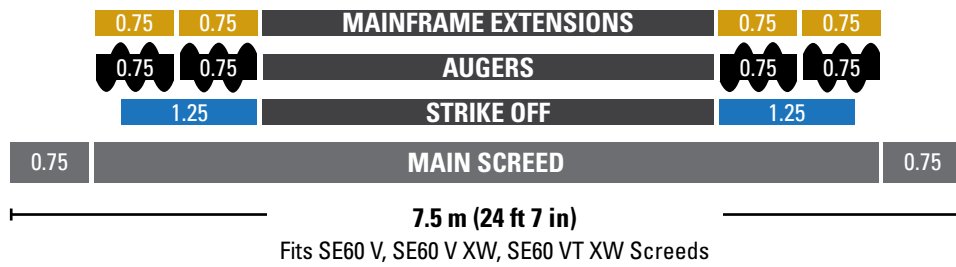
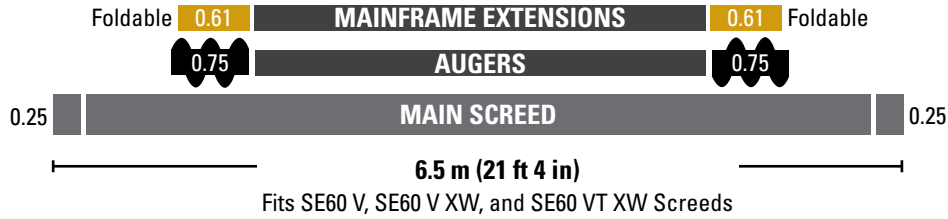



CAT GRADE CONTROL

FACTORY INTEGRATION, EASIER TO USE,
BETTER ACCURACY

Cat Grade Control is a factory-integrated guidance system that helps remove irregularities from the surface and control mat thickness for increased production, lower operating costs, and higher profitability.

Cat Dealers offer exceptional knowledge of the grade and slope system, as well as paver and screed operation, providing a single source that meets all your paving needs.

Note: Cat Pavers are able to utilize a variety of other Grade Control systems to support customer preferences.

USER FRIENDLY

- Operate from any of the two tractor or screed consoles
- Utilize split screen mode to monitor each side of the screed
- On-the-go sensor selection in auto-mode when utilizing the averaging beam, no need to stop and re-calibrate
- Text-based LCD displays provide visual reference
 - Available in multiple languages
 - Brightness and contrast controls for various lighting conditions
 - Previous settings automatically stored, no need to re-configure
- LCD Displays integrate machine settings to keep operator better informed of operating conditions while monitoring grade control

PRECISE CONTROL

- More accurate control, maximizes mix utilization, saves money
- True averaging, sonic sensors utilize 5 transducers, 2 readings discarded and 3 averaged
- 10-point Auto-Calibration, eliminates over/under adjustment from single calibration point
- Cross-coupling, slope and elevation maintained with height adjustments
- True 9 m (30') sonic averaging beam, tow point movement is 1/3 of total grade deviation

HIGHLY RELIABLE

- Water-resistant displays
- Factory installed components, consistent routing and location
- Sealed components withstand heat, moisture, and vibration
- Built-in temperature sensors provide better reliability than bail-type sensors
- Lockable enclosure provides vandal protection
- Easy diagnostics, compatible with Cat Electronic Technician

SINGLE SOURCE PROVIDER

- Cat dealers offer complete support of entire system including paver operation, screed setup, application and service training, consulting, and parts support
- No reason to utilize outside suppliers and risk improper setup



- | | |
|---------------------------|---------------------------------|
| 1. Soft Key Adjustment | 6. Machine Condition Slider Bar |
| 2. Bench Key | 7. Target Reference |
| 3. Auto Mode | 8. Measured Reference |
| 4. Left Sensor Selection | 9. Sensor Connectivity |
| 5. Right Sensor Selection | |



“The integration is a real advantage. It has the controls on each side of the paver and each side of the screed.”

– Cat Paving Contractor

THE ULTIMATE MANAGER

PRODUCT LINK HELPS REDUCE COSTS ACROSS THE FLEET

Product Link gets you accurate, timely and useful information about the location, utilization and condition of your equipment.

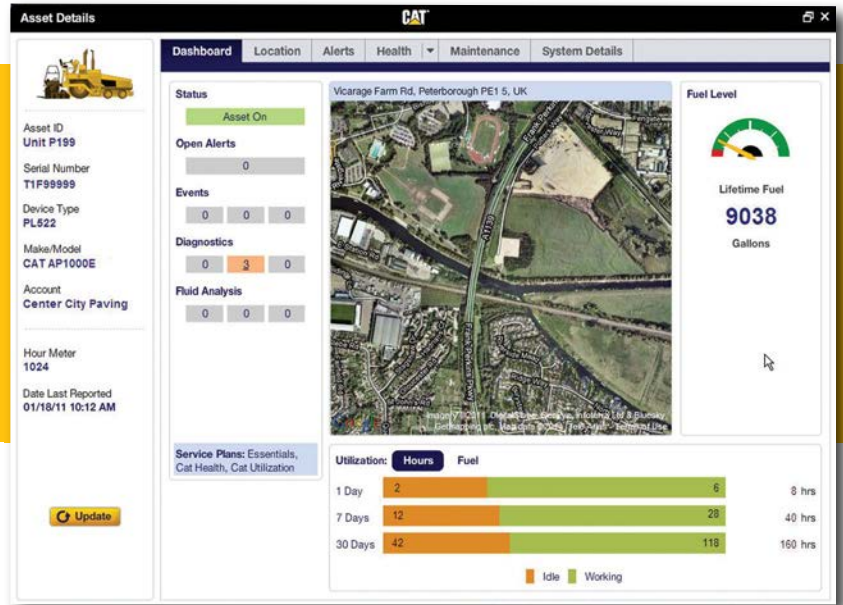

TIMELY MAINTENANCE MANAGEMENT

- Easily plan and track maintenance
- Start with “built-in” Caterpillar recommended service intervals and customize to match your fleet and job needs
- See what service has been done and what is due at a glance
- “Click-through” features make it easy to contact your Cat Dealer for service and maintenance

CUSTOMIZED ALERTS & DISPLAYS

- See all alerts on one screen, or any that you specify
- Prioritize information; service alerts, operator-generated errors, etc.
- Send alerts to the people who need them via email or text message

USER-FRIENDLY DASHBOARD

- See individual machine status instantly
- Monitor current fuel level and total usage
- Stay on top of past due alerts
- Idle vs. Work Time graph helps you monitor utilization

ROBUST GEO-FENCING

- Street maps and satellite view simplify set up of site boundaries
- Easily draw complex, accurate boundary shapes
- Provides valuable asset tracking and security monitoring tools

IDLE TIME VS. WORKING TIME

- Instantly relate and compare utilization of all assets on a job site
- Make better informed equipment decisions. Are there enough trucks delivering material or too few?

FAST PARTS ORDERING

- VisionLink™ provides “to do” checklists for common preventive maintenance and service procedures.
- “Built-in” parts lists for common procedures
- Click-through to PartStore™ and automatic loading of parts lists speed and simplify ordering.

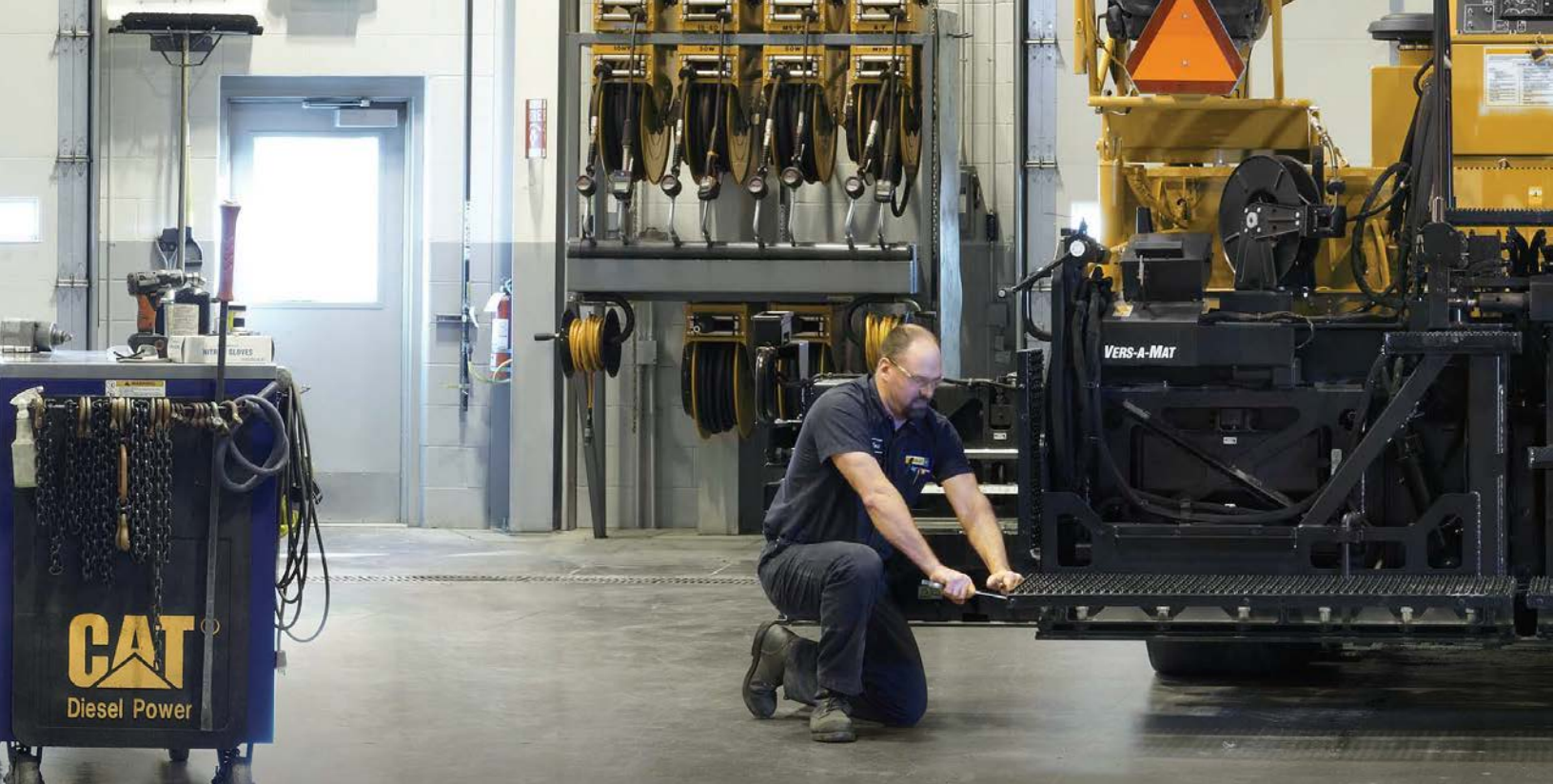

SINGLE SUPPLIER

CAT DEALERS OFFER SUPPORT AND TRAINING

CAT DEALER SUPPORT

- Cat Financial Services to meet all of your business needs
- 24 Hour Parts Support, get parts when and where you need them
- Help you develop a custom repair option to meet your unique needs
- Project Consulting, optimize performance of your equipment
- Service Training, increase knowledge of machine components in order to minimize downtime
- Paver Operator Training (P.O.T.), optimize machine performance

“Until now, we didn’t realize what good customer support was.”

– New Cat Paving Customer

Cat dealers offer the highest level of support available. Whether it’s parts support, application support, machine support, or financial support, we offer it. Customer satisfaction continues to be our number one goal!

PAVING AMPLITUDE CALCULATOR

The Paving Amplitude Calculator App is a productivity tool that helps road construction professionals determine the proper amplitude setting for their asphalt compactor to maximize compaction efficiency.

FEATURES

- Metric and U.S. measurements
- Cat roller models are preloaded for easy calculations
- End Result specs for North America
- Method specs for Europe



DOWNLOAD THE APP

STEP 1: Open the App Store on your Apple device.

STEP 2: Search “paving amplitude”. (If using an iPad, be sure to change your search to include iPhone apps.)

STEP 3: Locate App and Install.



REQUIREMENTS

Compatible with iPhone, iPod touch, and iPad. Requires iOS 7.0 or later.

PAVING PRODUCTION CALCULATOR

The Paving Production Calculator is a tool for asphalt paving professionals to plan their paving jobs by helping to estimate trucking needs, paving speeds, compaction and other factors.

FEATURES

- Modeled after the popular Production Calculator on CD
- Metric and U.S. measurements
- Save specs for each job for later reference
- Email job summaries from your device



DOWNLOAD THE APP

STEP 1: Open the App Store on your device.

STEP 2: Search for the app in the app store.

iTunes – “Production Calculator” (If using an iPad, be sure to change your search to include iPhone apps.)

Google Play – “Caterpillar Paving Calculator”

STEP 3: Locate App and Install.



REQUIREMENTS

Compatible with iPhone, iPod touch, and iPad. Requires iOS 7.0 or later and Android 2.3.3 and up

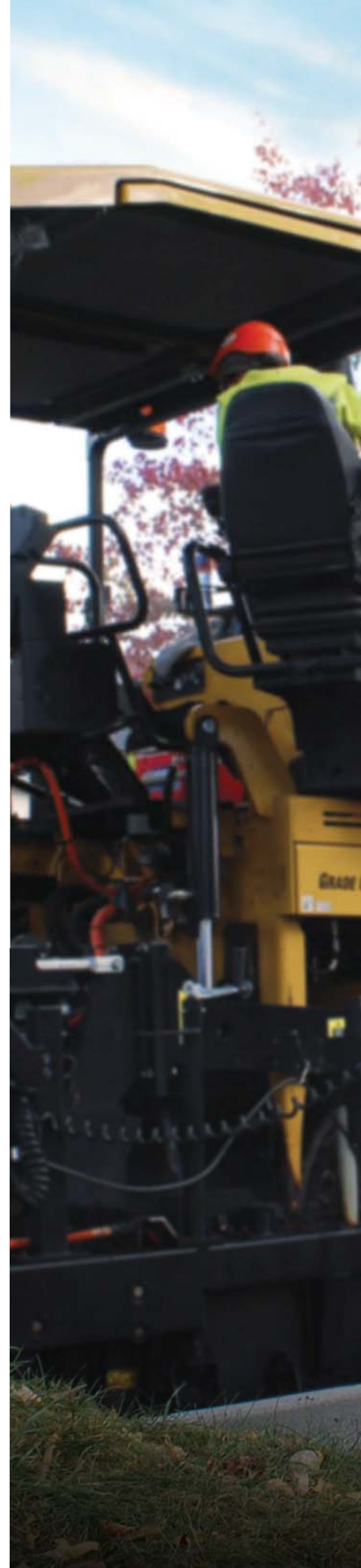

PROJECT PLANNER

FREE MOBILE APPS LEND A HAND





TRAINING & SOLUTIONS

PROVEN TO INCREASE PROFITS

Whether it's maintaining your equipment, improving your operator's skills, or updating your crew's techniques, Caterpillar and your Cat dealer are there to support your efforts and improve your bottom line.



Bonuses, penalties, tight specifications and tight deadlines. Today, more than ever, you're taking on more project responsibility—and more risk. At Caterpillar we understand the challenges you face, and we have the solutions to help you minimize the risk and maximize your profitability and success.

Caterpillar Paving Products is dedicated to providing you with quality training and project consulting services. We help each crew member understand what their role is and how it effects the paving operation. Providing this type of understanding not only improves efficiency and quality, it also increases your profit.

TRAINING DESIGNED FOR YOU

- Small classes offer hands-on opportunities
- Consulting solutions ensure success on the job
- Hundreds of years of industry knowledge and experience worldwide—average of 20 years per person
- Technical training to improve your technician's troubleshooting skills and minimize machine down time
- Operations training to improve your operator's skills and increase project quality
- On-demand customized training where you need it, when you need it, to minimize the amount of time your crew is away from the job
- Project Consulting to help your crew achieve consistent paving quality and maximize the bottom line

Having a goal like being the paving industry sales leader is no small challenge, even for the worldwide leader in the manufacture of equipment for the construction industry.

But ever since we sold our first paving equipment in 1986, we have continued to grow. Over the years, our machines have been recognized as dependable and rugged, easy to use and highly productive.

We have introduced innovations that have changed the way the world builds roads, features that our competitors now offer on their machines.

And with each new generation of machines we introduce, more and more customers around the world make the decision to switch to Cat.

For more complete information on Cat products, dealer services, and industry solutions, visit us on the web at www.cat.com.

BUILT FOR IT.™



QEHQ1822-04 (10/15)
© 2015 Caterpillar
All Rights Reserved

Materials and specifications are subject to change without notice.

VisionLink is a trademark of Trimble Navigation Limited, registered in the United States and in other countries.

Featured machines in photography may include additional equipment for special applications.

CAT, CATERPILLAR, BUILT FOR IT, their respective logos, and "Caterpillar Yellow" and the POWER EDGE trade dress, as well as corporate and product identity used herein, are trademarks of Caterpillar and may not be used without permission.

