



# Soil Stabilizer/Reclaimer

# SX-6



#### ENGINE

SX-6e: Tier 4i; Cummins® QSX15 620 hp (447 kW) Diesel @ 1,850 rpm  
SX-6ex: Tier 3; Cummins® QSX-15 620 hp (447 kW) @ 1,850 rpm\*

\* ex machines for lesser regulated countries

#### OPERATING WEIGHT

73,000 (33,180 kg)



### **Roadtec — An Astec Industries Company**

Roadtec, Inc. is proud to be a part of the family of companies that make up Astec Industries, Inc. Founded in 1972, Astec Industries, has grown to become America's leading manufacturer of equipment for asphalt road building, aggregate processing, oil, gas and water well drilling and wood processing. Roadtec continues to be an industry leader together with Astec Industries, by applying Astec's model of creative thinking bolstered by a corporate culture renowned for putting customer service first.





## THE ROADTEC DIFFERENCE: DELIVERING QUALITY AND INNOVATION WITH SUPERIOR CUSTOMER SERVICE

### **Dependability**

Roadtec has been manufacturing innovative, heavy-highway equipment since 1981. We continue to grow and add new products, yet our personal connection to our customers and our ability to respond immediately to your needs is even stronger.

### **Customer Service**

Our customers benefit from our strong focus on customer support after the sale. In-the-field service technicians live in the regions where they work and respond quickly. 24/7 parts support will get you the right parts fast, and at a fair price. Our product specialists will train your people on any newly purchased machine, and we also offer industry-leading training at our state-of-the-art training facility or in the field.

### **Count on Roadtec Equipment**

We don't build roads. We make the equipment so you can cost-effectively build and maintain the world's roads. With the Roadtec heavy-duty design, we are able to keep your machine working longer while lowering maintenance and operating costs. We are also able to make your operators more comfortable and confident with our user-friendly design and our customization for special projects.



## A RARE COMBINATION OF POWER AND MOBILITY LETS YOU EXCEL IN A VARIETY OF APPLICATIONS

### **New Generation of Machines**

The new generation of Roadtec machines arrives with a slight change in terminology used to classify each model. The model number of each new machine will include the letters “e” or “ex”. The single letter “e” denotes that the machine’s engine has a Tier IV emissions rating. The letters “ex” denote that the machine’s engine has a Tier III emissions rating. The “ex” models are machines exported to countries that do not require a Tier IV emissions rating. All features listed in this brochure apply to both “e” and “ex” models.

### **Versatility**

With a clean-running 620 hp (447 kW) Cummins® QSX15 engine and a weight of 73,000 (33,180 kg), the mid-size SX-6 offers a rare combination of power and mobility allowing it to excel in different applications. The SX-6 is equipped with a high performance 6-cylinder diesel engine that provides power to the rotor through a direct drum drive. The machine is capable of cutting up to 20” (508mm) deep and 100” (2,540mm) wide. Whether performing road rehabilitation, cold recycling, or soil stabilization, the Roadtec SX-6 will meet and exceed your expectations.

# BUILT TO WORK WITH STRENGTH AND PRECISION IN THE TOUGHEST ENVIRONMENTS

## Strong Frame & Hydraulic Suspension

The SX-6 is manufactured with a durable frame built at Roadtec from extremely strong A656 grade 80 steel. This steel has twice the yield strength as the mild steel used in other machines on the market. The custom-made frame is designed to perform in all terrains by providing substantial ground clearance. The wheels are suspended by four independently controlled hydraulically adjustable leg assemblies that are bolted to the mainframe. This feature allows the depth of cut to be selected via push button. The cutter housing is also securely fastened to the mainframe, providing strength and precision while the machine is working.



## Powerful & Efficient Cooling

The SX-6 cooling system introduces air from the top of the machine at the cleanest possible area, before it is exhausted away from the machine and engine through the rear radiator package. By pulling air from the top of the machine, the amount of dust traveling through the cooling system is limited. Clean-out panels provide convenient access for radiator maintenance. A variable speed fan also provides efficient cooling based on engine demand.

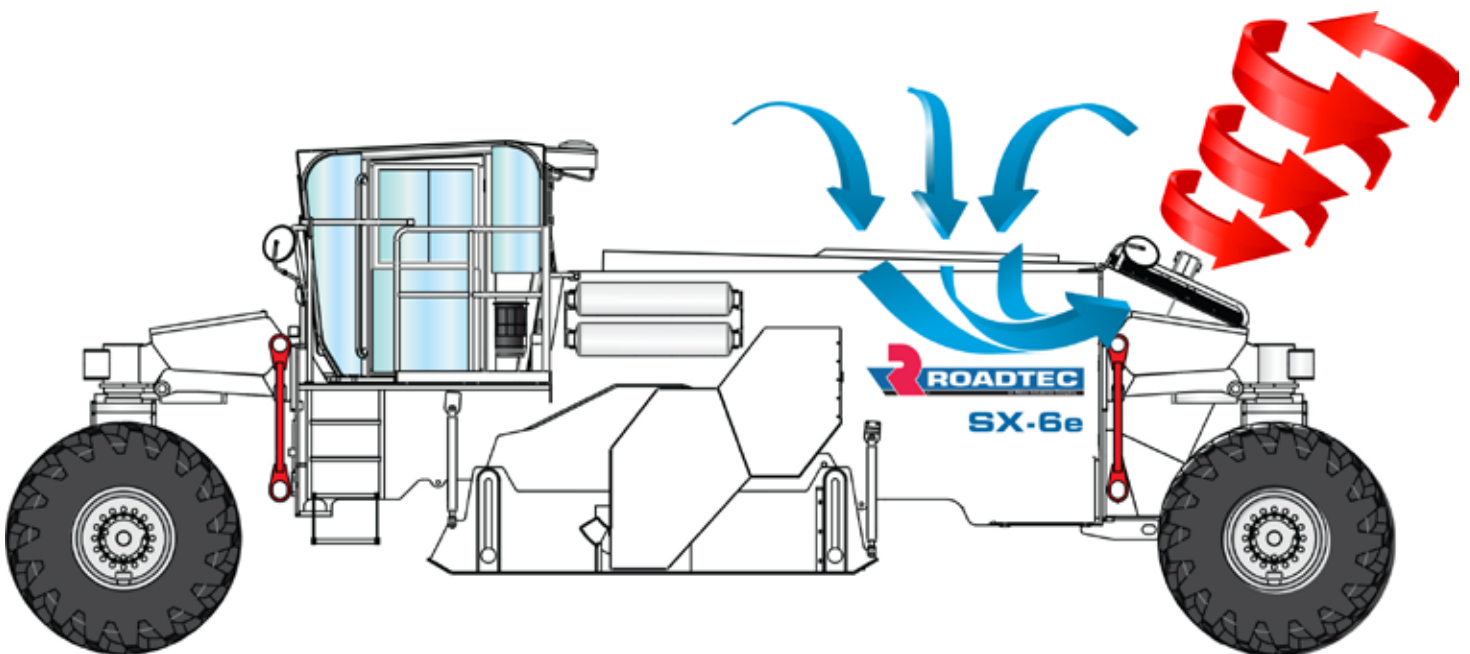





## EXCELLENT VISIBILITY, ERGONOMIC CONTROLS AND OPERATOR COMFORT INCREASE YOUR PRODUCTIVITY

### **Visibility & Operator Platform**

Designed for visibility and ease of operation, the operator's station seat slides laterally and swings 90° to help create the perfect vantage point from which to work. The operator platform also slides 18" past the right of the machine for additional visibility. A full view cab gives the operator an excellent view of the cutting edge and any obstacles that may be in the way. Mirrors on both sides provide the operator with additional viewpoints of the machine's surroundings.

### **Standard Backup Camera**

A backup camera system provides additional visibility while the machine is operated in reverse. A screen inside the cab conveniently displays the area directly behind the stabilizer as soon as reverse is selected. The back-up camera adds a level of comfort and convenience when navigating the SX-6 around other machines and obstacles.

## Controls & Steering

The machine's controls and display screen are conveniently arranged and move with the seat to allow for safe and convenient machine operation. Joystick controls and four different steering modes increase the machine's maneuverability and ease of operation.

## Comfortable & User Friendly Cab

The ergonomic design of the sealed (ROPs) certified cabin ensures operator comfort and safety. An air-conditioning and heating system along with a cab pressurizer give the operator a comfortable and dust-free environment to work in. The cabin is also built with soundproofing to keep noise levels down.



# IDEAL WEIGHT PLACEMENT AND A BALANCED FOUR-WHEEL DRIVE PROVIDE OPTIMAL POWER DISTRIBUTION

## Weight Balance & Power Allocation

Weight balance and power allocation are critical in all stabilization and reclamation applications. The weight of the SX-6 is perfectly distributed between the two axles, allowing the machine's 600 horsepower to be applied as efficiently as possible with maximum tractive effort. Four individual drive pumps that deliver 100% traction control propel the SX-6. With ideal weight placement and balanced four-wheel drive, the machine is better equipped to consistently perform in the most difficult project environments.



# CUSTOM DESIGN FEATURES AND EASY MAINTENANCE ACCESS SAVES YOU TIME ON THE JOBSITE

## Variable Geometry Cutter Housing

A variable geometry cutter housing enables the SX-6 to achieve superior cutting, sizing and mixing. The custom designed cutter housing and forward center positioned cutter provides the optimum amount of space between the cutter and housing allowing for superior material sizing and flow. Additional room behind the drum allows for exceptional mixing and incorporation of additives. Heavy duty, hydraulically adjustable front and rear doors allow for further control of sizing and material flow.

## Air-Shift Cutter Transmission

An air-shift four-speed transmission allows the quick change of cutter speeds without a loss in production on the SX-6. The operator can select the appropriate cutter speed for the current conditions without making modifications to the cutter drive, saving an enormous amount of time and effort when configuring the machine to different conditions.

## Cutter Drum & Drive

The SX-6 has a cut width of 100" (2.54m). A variety of drum options are available to obtain a cut depth of 20 inches. Heavy-duty quick change and welded bases are available along with different tooth spacing to better fit the demands of your project environments. The SX-6 cutter is driven by a mechanical v-belt drive. The multi groove v-belts are hydraulically tensioned, delivering consistent, efficient power to the cutter drum. Boltless entry to the cutter drive also provides quick and easy maintenance access.







## EASY ACCESS

- Hydraulically adjustable doors allow for better access to the engine compartment.
- Ground level, slide-out racks provide easier access to the machine's battery compartment.
- Boltless entry to the cutter drive provides quick and easy maintenance access.



### Electrical System

The SX-6 has a standard 24-volt electrical system with 105-amp alternator. CAN-based electronics with on-board and remote diagnostics allow simple troubleshooting throughout the machine.

### Lubrication Points

Grease maintenance points are clearly labeled with recommended amounts and conveniently placed around the machine to make preventative maintenance as convenient as possible.

## OPTIONS

### **Water & Emulsion Additive System**

- 500 gpm (1,893 lpm) capacity with fully automatic controls and manual override.

### **Expanded / Foamed Asphalt Additive System**

- Hot oil-jacked spray bar & foaming nozzles that pre-mix air and water with asphalt.

### **Tow Hitch**

- Rear assembly tow hitch to pull tanker.

### **20" (508 mm) Cut Depth**

- 58" (1,473 mm) diameter drum required.

### **Additional Lighting**

- (4) 24v high intensity discharge lights.

### **Additional Cameras**

### **Drum Spacing**

- 0.6" and 0.875"

### **EDGE™ Extended Equipment Warranty**

The EDGE™ Extended Equipment Warranty is an industry leading warranty that demonstrates our confidence in the quality and reliability of everything we make. This warranty goes above and beyond power train or extended engine warranties currently offered in the industry by covering more components and repairs as well as covering repairs done by the customer for a term of 3 years or 3,000 hours on the machine and 5 years or 6,000 hours on the engine. By covering most components other than wear items at full replacement cost and for a longer time period, the EDGE™ warranty gives owners an edge over their competition by lowering their operating costs.





# SPECIFICATIONS

## ENGINE

- SX-6e: Tier 4i; Cummins® QSX15 600 hp (447 kW) Diesel @ 1,800 rpm
- SX-6ex: Tier 3; Cummins® QSX-15 600 hp (447 kW) @ 1,800 rpm

## WEIGHT

- Shipping weight.....70,000 lbs (31,818 kg)
- Operating weight .....73,000 lbs (33,180 kg)

## ELECTRICAL SYSTEM

- CAN-bus serial communication systems for superior performance, reduced wiring, increased reliability & improved service and maintenance features.

## PROPEL SYSTEM

- 2-speed hydrostatic drive
- 4-wheel drive with individual pump and motor for each wheel

## SPEED

- Travel 6 mph (10 kph)
- Work 266 fpm (81 mpm)

## TIRES

- Heavy-duty, single-piece wheels prevent rim slippage and tire failure. High-flotation, deep tread 26LR28 tires.

## STEERING

- Joy stick-controlled. Four steering modes: coordinated steer, crab steer, front steer only, rear steer only.
- Turning radius 14' (4,267 mm) in cut

Cab can side-shift to the right 18" (457 mm)

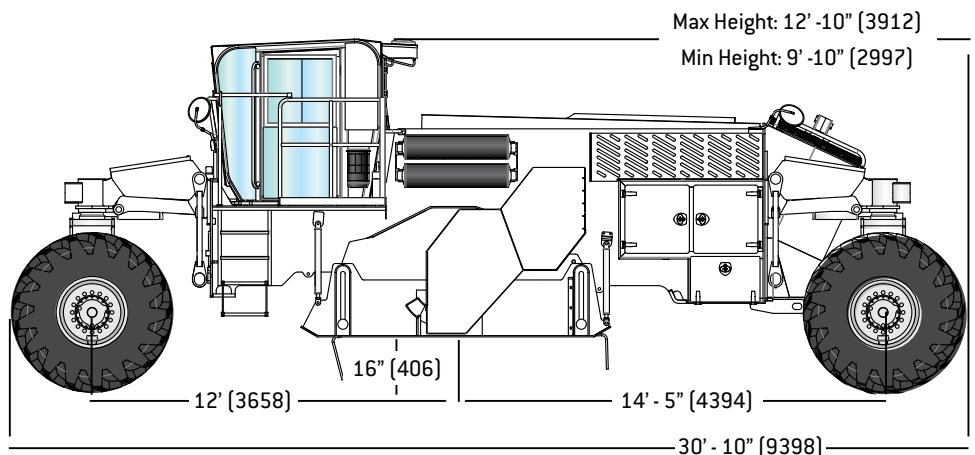
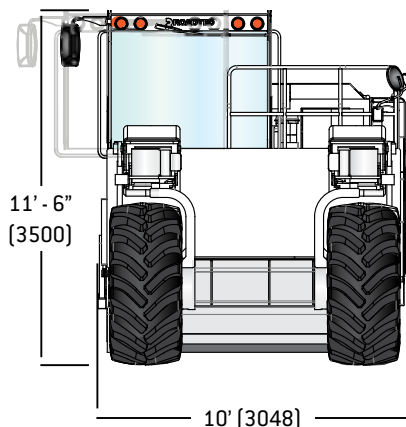

## OPERATOR STATION

- Fully enclosed and pressurized with A/C and heating system
- The cab can extend up to 18" (457 mm) past the right side of the machine

## INJECTION SYSTEM

- Water, emulsion, or foam/expanded AC
- Up to 500 gpm (1,893 lpm)

## SERVICE CAPACITIES

- Fuel Tank.....320 gal (1211 l)
- Hydraulic Fluid Tank ..... 62 gal (234 l)
- Air System ..... 30 gal (114 l)

## CUTTER SYSTEM FEATURES

### CUTTER SYSTEM

- Multi groove v-belts
- Hydraulic Clutch
- Four-speed air shift transmission
- Planetary gearbox final drive with auto belt tension

### CUTTER

- Right-hand flush cut
- Cutting width.....100" (2,540 mm)
- Cutting depth ..... 16" (406 mm) with 50" drum (1,270 mm)
- Max Cutting depth.....20" (508 mm) with 58" drum (1,473 mm)

### Cutting Speeds

- 87 rpm, 112 rpm, 138 rpm, 170 rpm



**ROADTEC.COM**

**ROADTEC** an Astec Industries Company

800 MANUFACTURERS RD • CHATTANOOGA, TN 37405 USA • 800.272.7100 • FAX 423.267.7104 • roadtec.com

12/10/14



© 2014 Roadtec, Inc. All Rights Reserved