

# GEHL®

## DL12-55 TELESCOPIC HANDLER

### PREVIEW

more lift height +  
more capacity

MAXIMIZE YOUR RETURN  
ON INVESTMENT

#### KEY FEATURES

- ✓ 12,000 lbs. (5443 kg) Rated Capacity
- ✓ 55'5" (16.8 m) Lift Height
- ✓ 115-hp Interim Tier IV John Deere Engine
- ✓ 4-Speed Powershift Transmission
- ✓ Four-Wheel Drive / Four-Wheel Steer
- ✓ Standard Foam-Filled Tires or Optional Solid Rubber Tires
- ✓ Standard Outriggers
- ✓ Exceptional Visibility and Spacious Cab
- ✓ Standard Auxiliary Hydraulics
- ✓ Adjustable Hydraulic System Controls to Fit the Comfort and Skill Level of the Operator



# DL12-55

## TELESCOPIC HANDLER

### SPECIFICATIONS

<b>CAPACITIES</b>	Lift Capacity (kg)	12,000 lbs. (5443)
	Maximum Lift Height (m)	55'5" (16.8)
	Capacity at Maximum Lift Height (kg)	5,500 lbs. (2495)
	Maximum Forward Reach (m)	40'9" (12.2)
	Capacity at Max. Forward Reach (kg)	2,000 lbs. (907)
	Max. Reach Below Grade (mm)	2'10" (864)
<b>ENGINE</b>	Manufacturer	John Deere
	Power (kW)	115 hp (86)
	Aspiration	Turbocharged
	Model	4045 Interim Tier IV
	Rated Speed	2400 rpm
<b>COMPONENTS</b>	Transmission	Dana 4-speed Powershift
	Maximum Travel Speed (km/hr)	22.8 mph (36.7)
	Selective Steering	4-wheel 2-wheel Crab
	Hydraulically Actuated Internal Wet-Disc Brakes	4-Wheel
	Parking Brake	Spring-Applied, Hydraulic Release (SAHR) on Front Axle
	Axle Manufacturer	Dana
<b>HYDRAULIC SYSTEM</b>	Pump Type	Dual Gear
	Total Capacity (L/min)	19 gpm (72) / 24 gpm (91)
	System Pressure (bar)	3,000 psi (207)
	Hydraulic Reservoir Capacity (L)	62.5 gal. (237)
<b>GENERAL SPECIFICATIONS</b>	Approximate Weight (kg)	27,500 lbs. (12,474)
	Length – Less Forks (m)	20'10" (6.35)
	Width (m)	8'3" (2.5)
	Ground Clearance (mm)	16" (406)
	Wheelbase (m)	10'8" (3.3)
	Turning Radius (m)	12'2" (3.7)
	Overall Height (m)	8'6" (2.6)
	Frame Leveling	±10°
	Fuel Capacity (L)	30 gal. (114)
<b>TIRE OPTIONS</b>	14.00 x 24 G2 16 Ply Foam Fill	
	14.00 x 24 Rock 16 Ply Foam Fill	
	14.00 x 24 Solid Rubber	

### LOAD CHARTS

Load charts are based on a 24" (610 mm) load center per ANSI/ITSEF B56.6

OUTRIGGERS DOWN

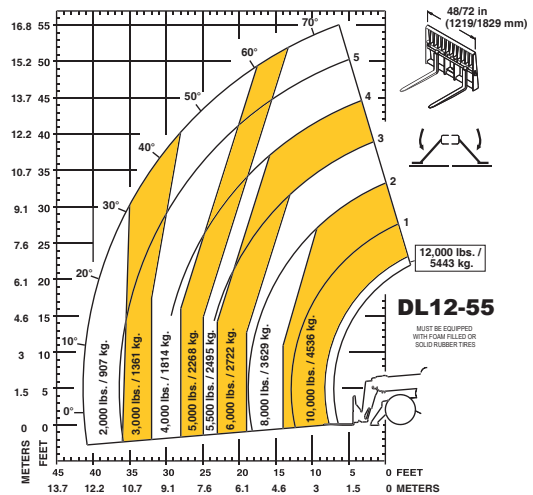

OUTRIGGERS UP

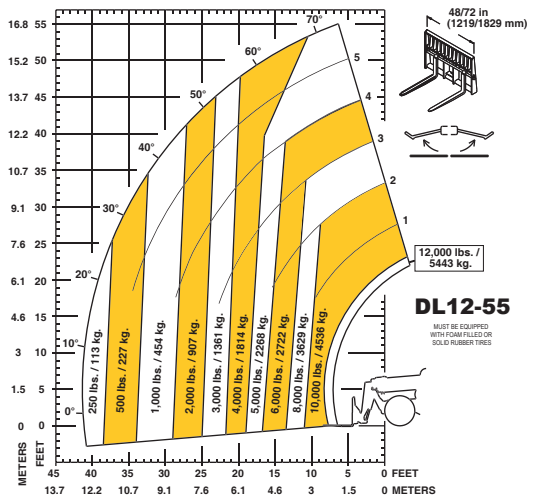

Gehl reminds users to read and understand the operator's manual before operating any equipment. Also, make sure all safety devices and shields are in place and functioning properly.

Gehl reserves the right to add improvements or make changes in features and specifications at any time without notice or obligation.

