



CAT[®] CT681 » TRUCK SPECIFICATIONS



EXTERIOR

- Curved, sloped, wraparound windshield
- Generous door opening, grab irons and skid-resistant steps
- Large, heated, cowl-mounted power mirrors
- Sealed-beam halogen headlights and LED park/turn lights
- Tow loops with 78,000-lb. rating
- Fixed grille to radiator

INTERIOR

- Wide cab design with spacious interior
- Tuned cab air suspension system
- Premium grade sound insulation
- Ergonomic dash and center stack
- Product Link asset and fleet management system
- Multiple driver seat options
- Combined standard and convex mirrors
- Tilt and telescoping leather-wrapped steering wheel
- Easy-to-reach compartments for quick access to paperwork and log books
- Overhead, under-dash and map lights
- Easy-access HVAC controls and vents
- Durable routing and clipping for long life

CHASSIS

- Set-forward axle
- 114" bumper to back of cab (BBC)
- 28" bumper to axle (BA)
- 12.25" rail size: 120,000 psi yield strength
- Above-rail radiator
- Integral front frame extension option

CAT CT13 ENGINE

- Cat CT13 ratings from 365 bhp to 430 bhp and 1,550 lb-ft peak torque
- Front Engine Power Take-Off (FEPTO)
- Advanced air management system
- High-pressure, common-rail fuel system
- Dual sequential turbochargers and high-pressure injection system
- Highly efficient Selective Catalytic Reduction (SCR) solution with upgraded in-cylinder technology and proven aftertreatment system
- Single Electronic Control Module (ECM)
- Unique engine ratings created specifically for vocational applications, resulting in the ultimate power/torque combinations
- Easy-access systems and components
- Compacted graphite iron block saves up to 500 pounds of weight compared to standard iron
- Fluid free head gasket

CAT CX31 AUTOMATIC TRANSMISSION

- Proven track record in vocational applications
- Full-power shifts and quick acceleration
- Ideal speed and torque combinations for improved fuel economy
- Two side PTO locations and Cat exclusive rear PTO
- Six forward speeds and one reverse speed
- Other transmission options available for the CT681 include the Manual and UltraShift PLUS Vocational Transmissions built by Eaton

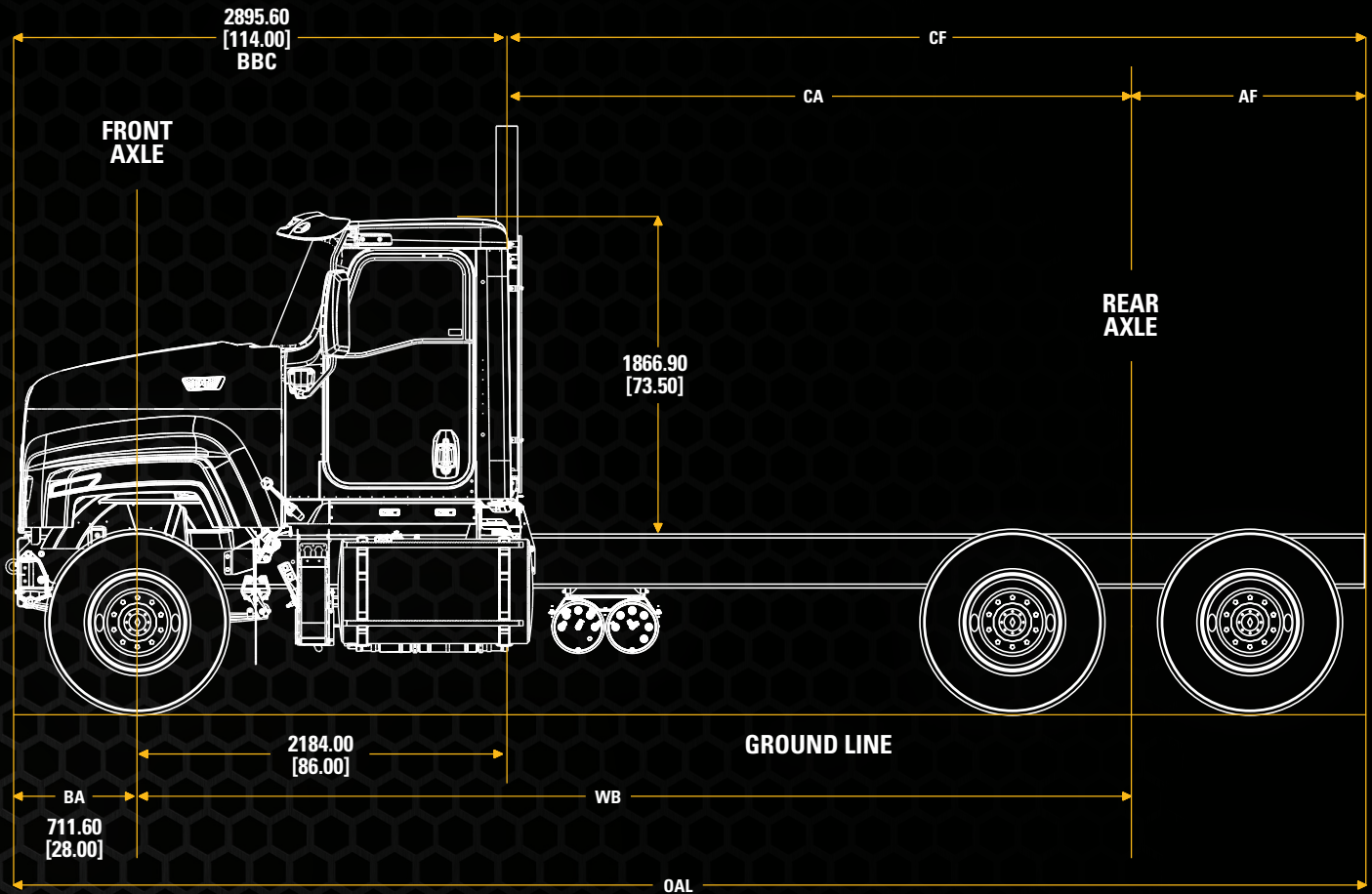

AXLES

- Meritor and Dana
- 6X4 truck configuration
- Tandems – Dana Spicer & Meritor 40,000-70,000 lbs. standard track
- Front axle – Meritor 12,000-20,000 lbs.

FRONT SUSPENSION

- Parabolic Taper Leaf for smoother ride
- Shock absorbers standard
- Two-stage Multi Leaf shackle type with shocks optional

REAR SUSPENSION

- Hendrickson suspension offerings HMX, RT/RTE, RS, R, PriMaxx
- Chalmers standard and high articulation
- Capacities from 40,000-85,000 lbs.

BRAKES

- AIR Dual System for straight truck
- Bendix anti-lock brake system, available with full vehicle wheel control system (four- or six-channel) and optional automatic traction control
- All systems meet federal stopping distance requirements
- Optional Haldex slack adjuster

FUEL TANKS

- Fuel tanks available in 80-, 100- and 120-gallon capacities
- Single left or dual under cab/back of cab options available
- Aluminum alloy construction



FOR MORE INFORMATION

VISIT DRIVECAT.COM OR TALK TO YOUR CAT DEALER TODAY TO LEARN MORE ABOUT THE CT681 AND THE REST OF THE CAT VOCATIONAL TRUCK LINE. JOIN US ONLINE TO STAY UP-TO-DATE ON THE LATEST CAT TRUCK AND INDUSTRY NEWS.



CAT VOCATIONAL TRUCKS



@CAT_TRUCK

