

## PLANETARY ANCHOR DRIVES

Suits Excavator 50-80 ton

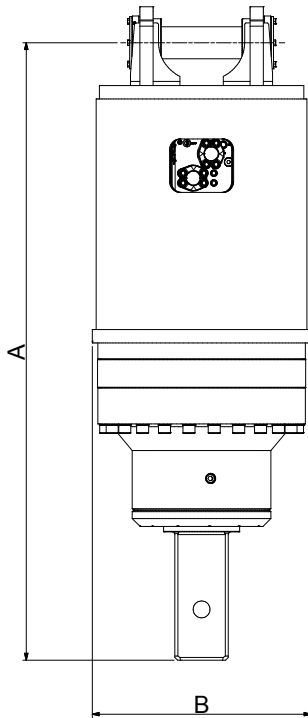

Developed in conjunction with the leading Screw Anchor/Pile installers around the world. The only true Anchor Drives available, designed & manufactured specifically for the rigours of the application. Host machine operates in the most efficient HP range, minimising wear & tear & optimising performance & returns.

### Features

- Highest volumetrically efficient motors available, ensure consistent & efficient pile installation throughout the working day
- Compact, High Quality, Australian made gearbox
- In built PRV (pressure relief valve) standard
- ECV (Energy Control relief Valve) to prevent rapid decompression of oil, caused by the reverse energy created by pile kick-back
- Engineered hood & ears for maximum strength
- Extreme duty shaft locking system
- No complex hoses, valving or filtration
- 2yr Gearbox & 1yr Motor Warranty

### Specifications

		XD 270	XD 310	XD 410	XD 500
Nominal Torque ft-lbs (Nm)		196,000 (265,000)	225,000 (310,000)	300,000 (405,000)	360,000 (490,000)
GD4 Motor	Max Flow gpm (lpm)	65 (250)	65 (250)	65 (250)	65 (250)
	Max Power hp (Kw)	127 (95)	127 (95)	127 (95)	127 (95)
TD3 Motor	Max Flow gpm (lpm)	100 (380)	100 (380)	100 (380)	100 (380)
	Max Power hp (Kw)	200 (150)	200 (150)	200 (150)	200 (150)
Max Pressure psi (bar)		3500 (240)	3500 (240)	3500 (240)	3500 (240)
Motor Type		Radial Piston	Radial Piston	Radial Piston	Radial Piston
PRV		Included	Included	Included	Included
ECV		Included	Included	Included	Included
Overall Length (A) in (mm)		95 (2410)	95 (2410)	95 (2410)	95 (2410)
Diameter (B) in (mm)		32.3 (820)	32.3 (820)	32.3 (820)	32.3 (820)
Weight (No Hitch/Oil) lbs (kg)		6345 (2878)	6345 (2878)	6345 (2878)	6345 (2878)
Shaft in (mm)		8 (200) Square	8 (200) Square	8 (200) Square	8 (200) Square





## EXCAVATORS 65GPM / 127HP

### Torque Output

Pressure PSI	XD 270		XD 310		XD 410		XD 500	
	Hi Torque Low Speed	Low Torque High Speed	Hi Torque Low Speed	Low Torque High Speed	Hi Torque Low Speed	Low Torque High Speed	Hi Torque Low Speed	Low Torque High Speed
700	39,200	20,527	45,966	24,070	60,142	31,493	72,493	37,960
800	44,800	23,459	52,532	27,508	68,734	35,992	82,849	43,383
900	50,400	26,391	59,099	30,947	77,325	40,491	93,205	48,806
1,000	56,000	29,324	65,665	34,385	85,917	44,990	103,561	54,229
1,100	61,600	32,256	72,232	37,824	94,509	49,489	113,917	59,652
1,200	67,200	35,188	78,798	41,262	103,101	53,988	124,273	65,074
1,300	72,799	38,121	85,365	44,701	111,692	58,487	134,629	70,497
1,400	78,399	41,053	91,931	48,139	120,284	62,986	144,985	75,920
1,500	83,999	43,986	98,498	51,578	128,876	67,485	155,341	81,343
1,600	89,599	46,918	105,064	55,016	137,468	71,984	165,697	86,766
1,700	95,199	49,850	111,631	58,455	146,059	76,483	176,054	92,189
1,800	100,799	52,783	118,198	61,893	154,651	80,982	186,410	97,612
1,900	106,399	55,715	124,764	65,332	163,243	85,481	196,766	103,035
2,000	111,999	58,647	131,331	68,770	171,834	89,979	207,122	108,457
2,100	117,599	61,580	137,897	72,209	180,426	94,478	217,478	113,880
2,200	123,199	64,512	144,464	75,647	189,018	98,977	227,834	119,303
2,300	128,799	67,444	151,030	79,086	197,610	103,476	238,190	124,726
2,400	134,399	70,377	157,597	82,524	206,201	107,975	248,546	130,149
2,500	139,999	73,309	164,163	85,963	214,793	112,474	258,902	135,572
2,600	145,599	76,242	170,730	89,401	223,385	116,973	269,258	140,995
2,700	151,199	79,174	177,296	92,840	231,976	121,472	279,614	146,417
2,800	156,799	82,106	183,863	96,278	240,568	125,971	289,971	151,840
2,900	162,399	85,039	190,429	99,717	249,160	130,470	300,327	157,263
3,000	167,999	87,971	196,996	103,155	257,752	134,969	310,683	162,686
3,100	173,599	90,903	203,562	106,594	266,343	139,468	321,039	168,109
3,200	179,199	93,836	210,129	110,032	274,935	143,967	331,395	173,532
3,300	184,799	96,768	216,695	113,471	283,527	148,466	341,751	178,955
3,500	195,999	102,633	229,829	120,348	300,710	157,464	362,463	189,800

Output speed and torque specifications are THEORETICAL. Speed and torque output are dependent on the overall system efficiencies associated with the prime movers hydraulic system. This document should be used for information and comparative purposes only. When determining criteria, & application specific information is required, please contact DIGGA.

## EXCAVATORS 65GPM / 127HP

### Speed Output

Flow GPM	XD 270		XD 310		XD 410		XD 500	
	Hi Torque Low Speed	Low Torque High Speed	Hi Torque Low Speed	Low Torque High Speed	Hi Torque Low Speed	Low Torque High Speed	Hi Torque Low Speed	Low Torque High Speed
8	0	1	0	1	0	1	0	0
11	1	1	1	1	0	1	0	1
14	1	1	1	1	0	1	0	1
17	1	2	1	2	1	1	1	1
20	1	2	1	2	1	1	1	1
23	1	2	1	2	1	2	1	1
26	1	3	1	2	1	2	1	1
29	2	3	1	3	1	2	1	2
32	2	3	1	3	1	2	1	2
35	2	4	2	3	1	2	1	2
38	2	4	2	3	1	3	1	2
41	2	4	2	4	1	3	1	2
44	2	5	2	4	2	3	1	2
47	3	5	2	4	2	3	1	3
50	3	5	2	4	2	3	1	3
53	3	6	2	5	2	4	2	3
56	3	6	3	5	2	4	2	3
59	3	6	3	5	2	4	2	3
62	3	6	3	6	2	4	2	4
65	4	7	3	6	2	4	2	4

**Safe & Secure optional  
storage & transport  
cradles available**

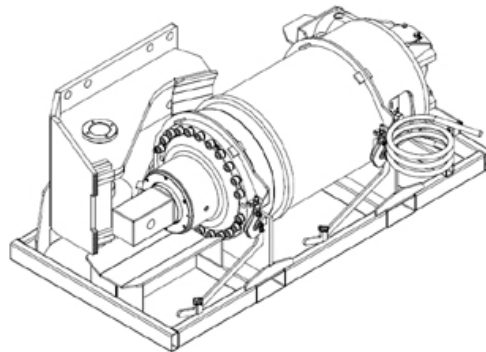

Output speed and torque specifications are THEORETICAL. Speed and torque output are dependent on the overall system efficiencies associated with the prime movers hydraulic system. This document should be used for information and comparative purposes only. When determining criteria, & application specific information is required, please contact DIGGA.



## EXCAVATORS 100GPM / 200HP

### Torque Output

Pressure PSI	XD 270		XD 310		XD 410		XD 500	
	Hi Torque Low Speed	Low Torque High Speed	Hi Torque Low Speed	Low Torque High Speed	Hi Torque Low Speed	Low Torque High Speed	Hi Torque Low Speed	Low Torque High Speed
700	38,551	19,276	45,205	22,603	59,147	29,573	71,293	35,646
800	44,058	22,029	51,663	25,831	67,596	33,798	81,478	40,739
900	49,566	24,783	58,121	29,060	76,046	38,023	91,662	45,831
1,000	55,073	27,536	64,579	32,289	84,495	42,248	101,847	50,924
1,100	60,580	30,290	71,036	35,518	92,945	46,472	112,032	56,016
1,200	66,087	33,044	77,494	38,747	101,394	50,697	122,217	61,108
1,300	71,595	35,797	83,952	41,976	109,844	54,922	132,401	66,201
1,400	77,102	38,551	90,410	45,205	118,294	59,147	142,586	71,293
1,500	82,609	41,305	96,868	48,434	126,743	63,372	152,771	76,385
1,600	88,117	44,058	103,326	51,663	135,193	67,596	162,955	81,478
1,700	93,624	46,812	109,784	54,892	143,642	71,821	173,140	86,570
1,800	99,131	49,566	116,242	58,121	152,092	76,046	183,325	91,662
1,900	104,638	52,319	122,699	61,350	160,541	80,271	193,510	96,755
2,000	110,146	55,073	129,157	64,579	168,991	84,495	203,694	101,847
2,100	115,653	57,827	135,615	67,808	177,440	88,720	213,879	106,939
2,200	121,160	60,580	142,073	71,036	185,890	92,945	224,064	112,032
2,300	126,668	63,334	148,531	74,265	194,339	97,170	234,248	117,124
2,400	132,175	66,087	154,989	77,494	202,789	101,394	244,433	122,217
2,500	137,682	68,841	161,447	80,723	211,238	105,619	254,618	127,309
2,600	143,190	71,595	167,904	83,952	219,688	109,844	264,803	132,401
2,700	148,697	74,348	174,362	87,181	228,138	114,069	274,987	137,494
2,800	154,204	77,102	180,820	90,410	236,587	118,294	285,172	142,586
2,900	159,711	79,856	187,278	93,639	245,037	122,518	295,357	147,678
3,000	165,219	82,609	193,736	96,868	253,486	126,743	305,541	152,771
3,100	170,726	85,363	200,194	100,097	261,936	130,968	315,726	157,863
3,200	176,233	88,117	206,652	103,326	270,385	135,193	325,911	162,955
3,300	181,741	90,870	213,109	106,555	278,835	139,417	336,096	168,048
3,500	192,755	96,378	226,025	113,013	295,734	147,867	356,465	178,232

Output speed and torque specifications are THEORETICAL. Speed and torque output are dependent on the overall system efficiencies associated with the prime movers hydraulic system. This document should be used for information and comparative purposes only. When determining criteria, & application specific information is required, please contact DIGGA.



EXCAVATORS 100GPM / 200HP

Speed Output

Flow GPM	XD 270		XD 310		XD 410		XD 500	
	Hi Torque Low Speed	Low Torque High Speed	Hi Torque Low Speed	Low Torque High Speed	Hi Torque Low Speed	Low Torque High Speed	Hi Torque Low Speed	Low Torque High Speed
8	0	1	0	1	0	1	0	0
11	1	1	1	1	0	1	0	1
14	1	2	1	1	1	1	0	1
17	1	2	1	2	1	1	1	1
20	1	2	1	2	1	1	1	1
23	1	3	1	2	1	2	1	1
26	1	3	1	2	1	2	1	2
29	2	3	1	3	1	2	1	2
32	2	4	2	3	1	2	1	2
35	2	4	2	3	1	3	1	2
38	2	4	2	4	1	3	1	2
41	2	5	2	4	1	3	1	2
44	2	5	2	4	2	3	1	3
47	3	5	2	4	2	3	1	3
50	3	6	2	5	2	4	2	3
53	3	6	3	5	2	4	2	3
56	3	6	3	5	2	4	2	3
59	3	7	3	6	2	4	2	4
62	3	7	3	6	2	4	2	4
65	4	7	3	6	2	5	2	4
68	4	8	3	6	2	5	2	4
71	4	8	3	7	3	5	2	4
74	4	8	4	7	3	5	2	4
77	4	9	4	7	3	6	2	5
80	4	9	4	8	3	6	2	5
83	5	9	4	8	3	6	2	5
86	5	10	4	8	3	6	3	5
89	5	10	4	8	3	6	3	5
92	5	10	4	9	3	7	3	6
95	5	11	5	9	3	7	3	6
98	5	11	5	9	4	7	3	6
101	6	11	5	10	4	7	3	6

Output speed and torque specifications are THEORETICAL. Speed and torque output are dependent on the overall system efficiencies associated with the prime movers hydraulic system. This document should be used for information and comparative purposes only. When determining criteria, & application specific information is required, please contact DIGGA.