

168HP | 3.7 – 4.2 yd<sup>3</sup>  
BUCKET CAPACITY

 **Kawasaki**

**70Z71**



**ONE FOCUS. COMPLETE SOLUTIONS.**

# INTRODUCING A NEW E.P.I.C. GENERATION

## 70Z7

### 70Z7 FEATURES:

- Fuel efficient Cummins engine
- Powerful
- Total redesign, stylish
- Comfortable cab
- Great visibility
- Easy read LCD display
- Smooth shifting
- Quiet

### EFFICIENT. POWERFUL. INTELLIGENT. COMFORTABLE.

Kawasaki pioneered the Z-Link design to provide unmatched utility, high breakout force and efficiency in its loaders. The Z7 generation implements brand-new patented technology, industry exclusive innovation, and input from owners and operators all over the world. We've engineered the Z7 series from the ground up!

#### EFFICIENT

Quick Cycle functions and PowerTrain Efficiencies work together through the IntelliTech Operating System to improve operating efficiency and reduce operating costs.

#### POWERFUL

Custom Operating Power Modes, made available through the IntelliTech Operating System, maximize a High Engine Power Rating to provide power on demand.

#### INTELLIGENT

The Kawasaki IntelliTech Operating System uses logic and intelligence to adjust the operating characteristics of the loader. Our intuitive system captures every aspect of working conditions and operating demands to adjust the powertrain and hydraulics for best application requirements. All of the IntelliTech features are designed to maximize performance.

#### COMFORTABLE

The new Z7 operator compartment features a low-profile dash, full-length glass doors, panoramic front window and well-organized storage areas — plus much more. We have total operator comfort in mind!





## DEFINING A NEW STANDARD

Kawasaki defines a new standard in production class wheel loaders with the introduction of the 70Z7 — a model that reflects the advanced engineering required to improve operating efficiencies while lowering operating costs through a highly intuitive, patented technology, the IntelliTech System.

IntelliTech is a family of technological innovations by Kawasaki to enhance the performance of the Z7 loader series. It is a comprehensive package of features that affects all phases of the wheel loader application.

These features use logic or intelligence to adjust the operating characteristics of the machine, sensing the working conditions and adjusting the powertrain and hydraulics to best match application or environmental requirements. Many of the IntelliTech operations are automatic, while others allow the operator to select functions appropriate for the application or work environment.

- 24-Hour Parts Service
- In House Rebuild Center
- Flexible Warranty Programs
- Custom Dealer Service Programs



*KCMA provides a totally focused approach to supporting your business. From carefully designed programs and services, to engineered special applications options, the 70Z7 wheel loader is ready to tackle the most demanding applications and environments.*





# EFFICIENT.

Efficiency is getting the job done with the least amount of waste. The Z7s are very efficient loaders. The hydraulic system is designed for maximum performance and efficiency. The systems and controls allow for efficient operation. And servicing is efficient and reduces operating costs even further.

## EFFICIENT HYDRAULICS

- Industry Exclusive, open center system for better feel and response
- Fuel efficient, load sensing, piston pump hydraulics
- Excavator style system, proven performance
- Efficient, proven Z-linkage for excellent digging performance

## EFFICIENT OPERATION

- Down Shift Switch allows for quick downshifting to meet operating conditions
- Shift Hold Button allows for holding in range to meet operating conditions
- AutoMode provides for Automatic 1st–5th, 2nd–5th or manual for optimal operation
- Normal and Power modes match the full range of demand
- Quick Power button allows for momentary high power demand

## EFFICIENT SERVICING

- Extended Lube Intervals from patented HN bushings — up to 500 hours
- Extended Hydraulic Oil Change Interval — 4000 hours when using KCM SuperEX46 fluid
- Extended Engine Oil Change Interval — 500 hours when using low ash, CJ-4 oil
- Accessible filters, ground level fueling, tank sight gauges, grouped grease fittings





# POWERFUL.

Power and productivity are what Kawasaki loaders are famous for. The Z7 has moved to another level in this area. Strong, responsive engines provide the power to get the job done. Powerful hydraulics make the work easy and the productivity high.

## POWERFUL ENGINE

- Cummins QSB6.7 Diesel with a big 168 net horsepower provides excellent power
- Tier 4i Certified, clean
- Reliable
- Fuel Efficient
- Responsive
- Adapted EGR technology reduces NOX and Particulate matter.
- Engineered with no DPF, requires No Regeneration

## POWERFUL HYDRAULICS

- Reliable piston pump
- Excellent breakout force
- Fast, Responsive
- Increased Steering Power

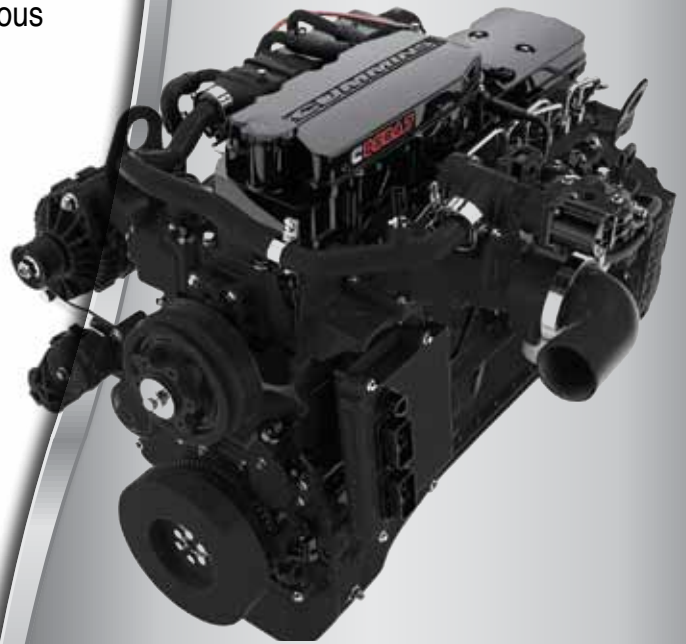

# INTELLIGENT.



Intelligence in a wheel loader means systems that adjust to the working conditions to improve efficiency and productivity. The IntelliTech system is a family of features that optimize the performance of the machine in any working condition.

## INTELLITECH SYSTEM

- Patented IntelliDig system balances Rimpull force and Hydraulic digging force to match conditions
- QuickCycle system speeds V-loading cycles
- FlexShift varies the shift points of the transmission to match working conditions

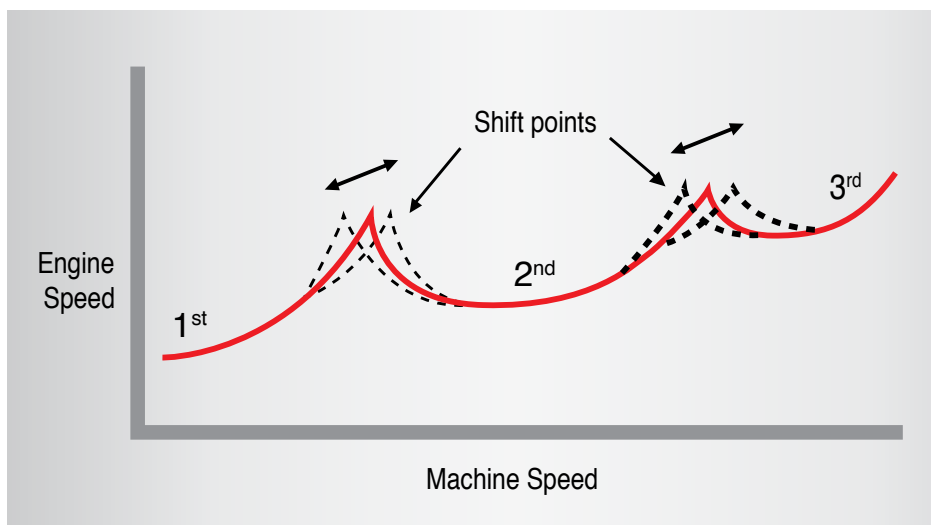



# INTELLIGENT.



## INTELLITECH SYSTEM

- Efficient Acceleration prevents wasted energy from over-accelerating and provides added power for fast acceleration
- Shockless Declutch provides smooth declutch function for level or slope operations
- Automatic Reversible Cooling Fan is controlled by multiple inputs for optimum operation
- Aerodynamic Fan blade design for quiet operation
- Auto Idle Shut Down senses excessive idling and shuts down engine to reduce fuel consumption.



# COMFORTABLE.

A comfortable operator is a productive operator. In the Kawasaki Z7s the operator comfort is outstanding. Quiet, convenient, clean, and designed for optimum operator comfort, safety, and productivity.

## COMFORTABLE CAB

- Large, quiet, well-sealed ROPS cab with great visibility in all directions
- Deluxe, ergonomic air suspension seat can be equipped with heated cushions
- Tilt/Telescoping steering column with pop-up pedal for convenient entry and exit
- High Visibility front dash design
- Excellent ventilation from sliding side windows and full-length glass, latch-back doors
- Adjustable side console to fit operator preference
- Standard AM/FM/CD/WB with AUX outlet and dual speakers
- Thermostatically controlled HVAC system for year-round climate control





# COMFORTABLE.

Improved Controllability. The full color LCD multi function instrument panel clearly provides information derived from IntelliTech, including machine operation and settings, plus HVAC controls, and fluid pressures. The monitor is very easy to see, as well as comprehend – the operator has several languages to choose from!

## CONVENIENT CONTROLS

- Multi-function instrument panel provides information and allows for control, adjustments and alerts
- Fingertip, Pilot-assisted hydraulic controls can be single or dual lever
- The Pilot controls, available in single or dual lever, also contain fingertip controls for the DSS (Downshift Switch), Quick Power Button, and Horn.
- An alternate Shift Hold Button is conveniently located in the hydraulic control console, along with the elevated forward/reverse switch.
- The adjustable arm console contains rocker switches for convenient selection of the "Power Mode," "1st Gear Activation," "Variable Declutch," "Control Lever Lock" and optional "Ride Control."
- Adjustable Side console to fit operator preference and "Dual Lift Arm Kick-Out"
- 12V outlet and 24V lighter outlet, dual interior lights





# SERVICE SIMPLIFIED

## EASY ACCESS

- Angled Ladders
- Wide-Access Engine Compartment Doors, Gull Wing
- Battery Disconnect
- Easy Access Battery Box
- Grouped Lube Points
- Ground Level Fluid Check Points
- Ground Level Fueling
- Autolube, Optional
- Automatic Reversible Cooling Fan, standard

## EXTENDED SERVICE INTERVALS

- HN Bushings impregnated with high viscosity oil extend lubrication period to 500 hours on loader linkage pins
- Extended Hydraulic Oil Change Interval
- Extended Engine Oil Change Interval





# BUCKET DATA

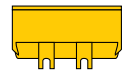
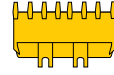
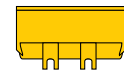
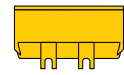

			Standard Boom			High Lift Boom
			General Purpose		Material Handling	General Purpose
			Straight Edge With Bolt-on Cutting Edge 	Straight Edge With Teeth & Segments 	Straight Edge With Bolt-on Cutting Edge 	Straight Edge With Bolt-on Cutting Edge 
Capacity	Heaped	yd <sup>3</sup> (m <sup>3</sup> )	3.7 (2.8)	3.7 (2.8)	4.2 (3.2)	3.7 (2.8)
	Struck	yd <sup>3</sup> (m <sup>3</sup> )	3.3 (2.5)	3.3 (2.5)	3.5 (2.7)	3.3 (2.5)
Maximum dumping clearance		ft-in (mm)	8'11 <sup>7</sup> / <sub>8</sub> " (2,740)	8'8 <sup>3</sup> / <sub>8</sub> " (2,650)	8'11 <sup>1</sup> / <sub>2</sub> " (2,730)	10'4" (3,150)
Dumping reach (to front of bucket edge or tooth)		ft-in (mm)	3'8 <sup>1</sup> / <sub>8</sub> " (1,120)	3'11 <sup>1</sup> / <sub>4</sub> " (1,200)	3'8 <sup>7</sup> / <sub>8</sub> " (1,140)	4'2" (1,270)
Max. hinge pin height		ft-in (mm)	12'10 <sup>3</sup> / <sub>8</sub> " (3,920)	12'10 <sup>3</sup> / <sub>8</sub> " (3,920)	12'10 <sup>3</sup> / <sub>8</sub> " (3,920)	14'2 <sup>1</sup> / <sub>8</sub> " (4,320)
Digging depth (with bucket level)		ft-in (mm)	3 <sup>1</sup> / <sub>2</sub> " (90)	4 <sup>3</sup> / <sub>8</sub> " (110)	3 <sup>1</sup> / <sub>2</sub> " (90)	6 <sup>3</sup> / <sub>4</sub> " (170)
Breakout force		lb (kN)	25,180 (112)	22,930 (102)	24,500 (109)	22,930 (102)
Bucket tilt-back angle	at ground level	degree	44°	44°	44°	45°
	at carry position	degree	50°	50°	50°	50°
Overall	Length	ft-in (mm)	25'11 <sup>3</sup> / <sub>8</sub> " (7,910)	26'5" (8,050)	26'1 <sup>1</sup> / <sub>2</sub> " (7,940)	27'7 <sup>1</sup> / <sub>8</sub> " (8,410)
	Height (to top of Cab/ROPS)	ft-in (mm)	10'9 <sup>1</sup> / <sub>8</sub> " (3,280)	10'9 <sup>1</sup> / <sub>8</sub> " (3,280)	10'9 <sup>1</sup> / <sub>8</sub> " (3,280)	10'9 <sup>1</sup> / <sub>8</sub> " (3,280)
	Height (bucket fully raised)	ft-in (mm)	17'4 <sup>5</sup> / <sub>8</sub> " (5,300)	17'4 <sup>5</sup> / <sub>8</sub> " (5,300)	17'5 <sup>1</sup> / <sub>2</sub> " (5,320)	18'8 <sup>3</sup> / <sub>8</sub> " (5,700)
	Width (outside tire)	ft-in (mm)	8'6 <sup>3</sup> / <sub>4</sub> " (2,610)	8'6 <sup>3</sup> / <sub>4</sub> " (2,610)	8'6 <sup>3</sup> / <sub>4</sub> " (2,610)	8'6 <sup>3</sup> / <sub>4</sub> " (2,610)
	Width (outside bucket)	ft-in (mm)	8'11 <sup>1</sup> / <sub>2</sub> " (2,730)	9'1" (2,770)	8'11 <sup>1</sup> / <sub>2</sub> " (2,730)	8'11 <sup>1</sup> / <sub>2</sub> " (2,730)
Tread		ft-in (mm)	6'8 <sup>3</sup> / <sub>4</sub> " (2,050)	6'8 <sup>3</sup> / <sub>4</sub> " (2,050)	6'8 <sup>3</sup> / <sub>4</sub> " (2,050)	6'8 <sup>3</sup> / <sub>4</sub> " (2,050)
Wheel base		ft-in (mm)	10'2" (3,100)	10'2" (3,100)	10'2" (3,100)	10'2" (3,100)
Clearance Circle (bucket carry position)	at outside of bucket	ft-in (mm)	40'10 <sup>1</sup> / <sub>2</sub> " (12,460)	41'2 <sup>1</sup> / <sub>2</sub> " (12,560)	40'10 <sup>1</sup> / <sub>2</sub> " (12,460)	42'2 <sup>1</sup> / <sub>4</sub> " (12,860)
	at outside tire	ft-in (mm)	36'7 <sup>3</sup> / <sub>8</sub> " (11,160)	36'7 <sup>3</sup> / <sub>8</sub> " (11,160)	36'7 <sup>3</sup> / <sub>8</sub> " (11,160)	36'7 <sup>3</sup> / <sub>8</sub> " (11,160)
Minimum ground clearance		ft-in (mm)	1'3 <sup>1</sup> / <sub>2</sub> " (395)	1'3 <sup>1</sup> / <sub>2</sub> " (395)	1'3 <sup>1</sup> / <sub>2</sub> " (395)	1'3 <sup>1</sup> / <sub>2</sub> " (395)
Full articulation angle		degree	40°	40°	40°	40°
Operating weight (with ROPS Cab)		lb (kg)	31,750 (14,400)	31,810 (14,430)	31,790 (14,420)	32,170 (14,590)
Static Tipping Load (with ROPS cab)	Straight	lb (kg)	26,410 (11,980)	25,970 (11,780)	26,170 (11,870)	20,610 (9,350)
	Full turn	lb (kg)	22,800 (10,340)	22,400 (10,160)	22,550 (10,230)	17,660 (8,010)

The weight and load figure includes optional counterweight, enclosed ROPS Cab, air conditioner, 20.5-25-12 (L-2) tires, full fuel tank and operator.

Materials and specifications are subject to change without notice and without obligation on the part of the manufacturer. The specifications supplied, while believed to be completely reliable, are not to be taken as warranty for which we assume legal responsibility.

**WEIGHTS AND DIMENSIONS**

		Operating Weight	Tipping Load			Overall Width (Outside Tire)	Overall Height	Overall Length
			Straight	Full Turn				
Remove ROPS Cab (for transport only)	lb (kg)	-1,190 (-540)	-1,100 (-500)	-900 (-450)	in (mm)		-5 1/2 (-140)	
Remove Optional Counterweight	lb (kg)	-680 (-310)	-1,740 (-790)	-1,540 (-700)	in (mm)			-3 1/8 (-80)
Tires: 20.5-25-12PR (L-3)	lb (kg)	+265 (+120)	+200 (+90)	+180 (+80)	in (mm)			
23.5-25-12PR (L-2)	lb (kg)	+1,410 (+640)	+1,060 (+480)	+940 (+425)	in (mm)	+3 1/2 (+90)	+2 9/8 (+60)	-2 1/8 (-55)
23.5-25-12PR (L-3)	lb (kg)	+1,830 (+830)	+1,370 (+620)	+1,210 (+550)	in (mm)	+3 1/2 (+90)	+2 9/8 (+60)	-2 1/8 (-55)

**BUCKET SELECTION CHART**

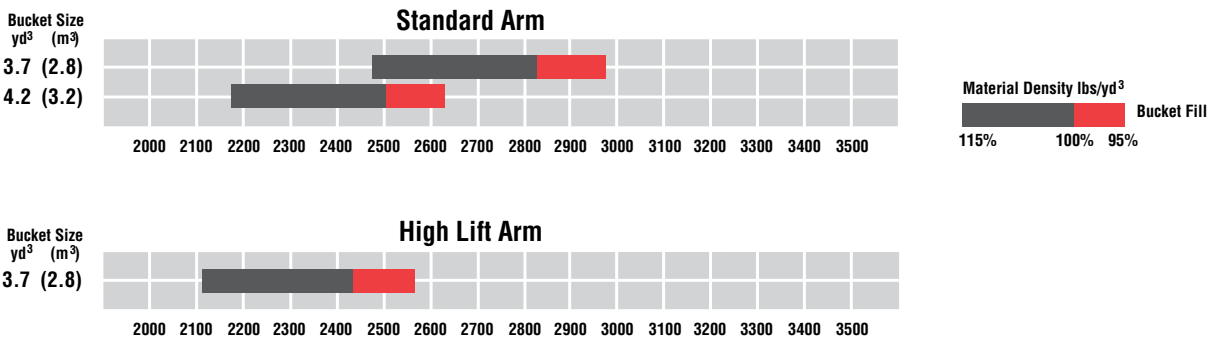

**OPTIONS**



**Quick Coupler, Traditional Plate Fabricated**

- For use with JRB 416 Attachments

**Quick Coupler, Full Cast**

- Full Cast, High Strength
- Versatile, Picks up JRB 416 and ISO attachments
- Increased Visibility



## DIMENSIONS

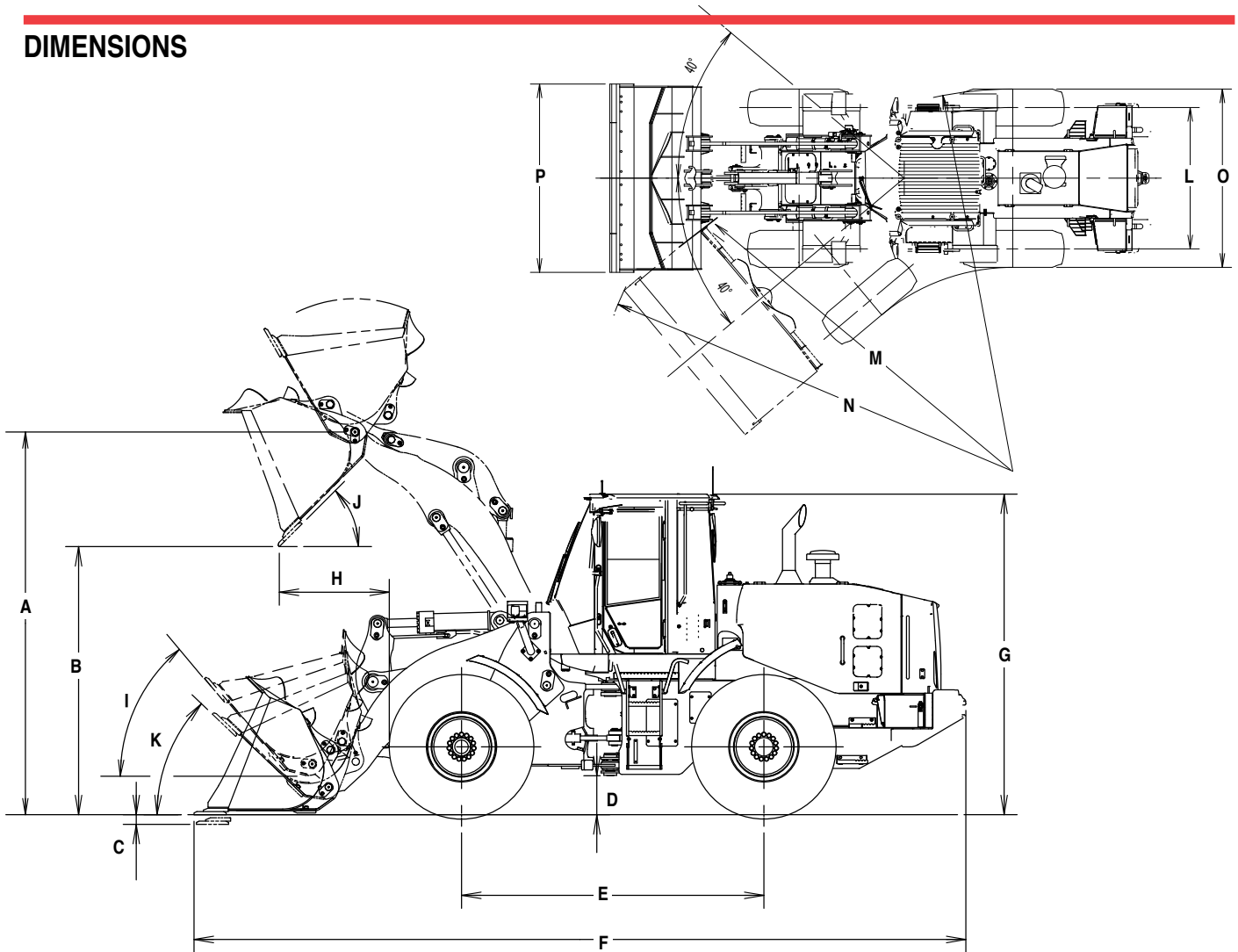

<b>A</b>	Hinge-Pin Height – Standard	12' 10 <sup>3</sup> / <sub>8</sub> "	3,920 mm
	Hinge-Pin Height – High-Lift	14' 2 <sup>1</sup> / <sub>8</sub> "	4,320 mm
<b>B</b>	Dumping Clearance	8' 11 <sup>7</sup> / <sub>8</sub> "	2,740 mm
	Dumping Clearance – High Lift	10' 4"	3,150 mm
<b>C</b>	Digging Depth	3' 1 <sup>1</sup> / <sub>2</sub> "	90 mm
<b>D</b>	Ground Clearance With 20.5-25 (See Tire Option Chart for Other Tires)	1' 3 <sup>1</sup> / <sub>2</sub> "	395 mm
<b>E</b>	Wheelbase	10' 2"	3,100 mm
<b>F</b>	Overall Length	25' 11 <sup>3</sup> / <sub>8</sub> "	7,910 mm
<b>G</b>	Height to Top of Cab/ROPS	10' 9 <sup>1</sup> / <sub>8</sub> "	3,280 mm
<b>H</b>	Dumping Reach – Standard	3' 8 <sup>1</sup> / <sub>8</sub> "	1,120 mm
<b>I</b>	Tilt-Back @ Carry	50°	50°
<b>J</b>	Dump Angle @ Maximum Lift	45°	45°
<b>K</b>	Tilt-Back @ Ground	44°	44°
<b>L</b>	Tread	6' 8 <sup>3</sup> / <sub>4</sub> "	2,050 mm

**Clearance Circle** – All dimensions are approximate and based on 20.5-25 (L-2) tires.

<b>M</b>	Clearance Circle to Outside of Tires	36' 7 <sup>3</sup> / <sub>8</sub> "	11,160 mm
<b>N</b>	Clearance Circle to Outside of Bucket	40' 10 <sup>1</sup> / <sub>2</sub> "	12,460 mm
<b>O</b>	Width Over Tires	8' 6 <sup>3</sup> / <sub>4</sub> "	2,610 mm
<b>P</b>	Width to Outside Bucket	8' 11 <sup>1</sup> / <sub>2</sub> "	2,730 mm

<b>ENGINE</b> (EPA Tier 4 Interim/EU Stage IIIB certified)	
Gross Power (SAE J1995)	173 HP/2,200 RPM (129 kW/2200RPM)
Net Power (SAE J1349) ISO 9249	168 HP/2,200 RPM (125 kW/2200RPM)
Make/Model	CUMMINS QSB6.7 diesel engine
Type	4-cycle, water-cooled, direct injection with turbocharger and air cooled intercooler
Fuel Type	#2 Diesel (Requires ultra-low sulfur fuel.)
Fuel Injection Pump	Electronically controlled, common rail type
Governor	All speed electrical type
Cooling Module Type	Hydraulic-driven, suction-type fan, pressurized radiator
Number of cylinders	6
Bore and stroke	4.213" x 4.882" (107mm x 124mm)
Total displacement	408.2 in <sup>3</sup> (6.69 liters)
Alternator	AC24V – 1.56 kW (65 amp)
Air Cleaner	Dry type (double element)
Starter Motor	DC 24V 7.8 kW (10.5 HP)
Battery	12V – 140AH (1,146 CCA), 2 units

<b>TORQUE CONVERTER AND TRANSMISSION</b>	
Torque converter	3 elements, single-stage, 1-phase
Transmission	Countershaft type, Full power shift
Speeds: Forward	1st: 3.7 MPH (5.9 km/hr) 2nd: 7.1 MPH (11.5 km/hr) 3rd: 10.8 MPH (17.4 km/hr) 4th: 15.7 MPH (25.3 km/hr) 5th: 23.9 MPH (38.5 km/hr)
Speeds: Reverse	1st: 3.9 MPH (6.2 km/hr) 2nd: 7.5 MPH (12.1 km/hr) 3rd: 16.5 MPH (26.5 km/hr)

<b>SYSTEMS REFILL CAPACITY</b>		
LOCATION	GALLONS	LITERS
Fuel tank (diesel fuel)	62.1	235
Engine lubricant (including oil pan)	6.6	25
Engine coolant	7.4	28
T/M & T/C	5.5	21
Axle (front/rear)	8.2/9.0	31/34
Hydraulic oil tank	26.4	100
Hydraulic system (including hydraulic tank)	39.6	150

<b>HYDRAULIC AND STEERING SYSTEM</b>		
Steering type	Articulated frame steering	
Steering mechanism	Hydraulic power steering unit, direct operated type	
Lift (boom) cylinder	Two (2) double-acting piston type: 4.921" x 30.118" (125mm x 765mm)	
Tilt (bucket) cylinder	One (1) double-acting piston type: 5.905" x 19.488" (150mm x 495mm)	
Steering cylinder	Two (2) double-acting piston type: 2.756" x 17.401" (70mm x 442mm)	
Main oil pump	Variable piston type: 55.5 GPM/710 PSI @ 2200 RPM (210 LPM/4.9MPa @ 2200 RPM)	
Pilot oil pump	Gear type: 9.3 GPM/566 PSI @ 2200 RPM (35.1 LPM/3.9 MPa @ 2200 RPM)	
Relief valve set pressure	Loading	3,974 psi, 27.4 MPa (280 kg/cm <sup>2</sup> )
	Steering	3,684 psi, 25.4 MPa (280 kg/cm <sup>2</sup> )
HYDRAULIC CYCLE TIME* front end loading, Z bar linkage system		
Lifting time (at full load)	5.9 sec.	
Lowering time (empty)	3.6 sec.	
Bucket dumping time	1.3 sec.	
TOTAL	10.8 sec.	

\* Measured in accordance with SAE J732C

<b>AXLE SYSTEM</b>	
Drive system	4-wheel drive
Front and rear axle	Semi-floating type
Tires	20.5 x 25-12PR (L-2) (L-3)
	23.5 x 25-12PR (L-2) (L-3)
Reduction and differential gear	Spiral bevel gear, limited slip, single stage reduction
Final reduction gear	Inboard mounted, internal planetary gear
Oscillation angle	±12°

<b>BRAKE SYSTEM</b>	
Service brakes	4-wheel, wet multiple disc brake. Controlled by full hydraulic system. Dual circuit.
Parking/Emergency brake	Spring-applied, oil pressure-released. Located on driveline.



## STANDARD EQUIPMENT

### Engine

Air cleaner, double element  
 Auto Idle Shut Down  
 Cold Start (Intake Air Heater)  
 Cooling Fan, Automatic Reversible  
 EGR System  
 Fuel filter

Fuel Pre-Filter, w/water separator  
 Cummins QSB6.7 diesel engine  
 VGT (Variable Geometry Turbocharger)  
 Work mode selector

### Powertrain

Brakes, Service  
 Enclosed Wet Disc  
 Dual System  
 Inboard Mounted  
 Brake, Parking  
 Spring Applied  
 Oil Pressure Released  
 Dry Disc Type  
 Differential, Limited Slip (F/R)  
 Down-Shift switch  
 Drive shafts, Low maintenance

1st speed hold switch on side console  
 F-R direction selector (2-Column mounted/HYD-control lever mounted)  
 Quick Power switch  
 Transmission, Automatic w/load sensing system.  
 Transmission declutch (3-position L/H/Off)  
 Transmission mode selection (3-position AUTO1/MAN/AUTO2)  
 Universal Joints, Sealed

### Hydraulic System

Boom Kick-Out, Dual (Operator adjustable in Cab)  
 Bucket Positioner  
 Control Lever, Single, Pilot-assisted  
 Control lever lock (Electric)  
 Control Valve, 2-spool, Tandem Control

Pump, Variable Displacement, Load-sensing  
 Steering, Pilot  
 System; Open-Center, High-Pressure, Load-sensing  
 Valve, Anti-Drift

### Electrical

24-volt electrical system  
 Back-up alarm  
 Batteries (2), 12V, 1,146 CCA  
 Battery disconnect switch  
 Converter, 12V/15 Amp  
 Horn, Dual Electric  
 Instrument Panel, LCD, Monochrome

Lights:  
 2 Headlights (Halogen)  
 2 Forward Working Lights (Halogen)  
 4 Rear Working Lights (Halogen)  
 2 Stop/Tail/Backup (LED)  
 Turn signal w/4-way flashers/Marker

### Cab

ROPS Cab: Enclosed cab with sound suppression, front & rear wipers and washers, two rear view and side mirrors, tinted glass, full view latch-back doors, sliding side windows.  
 Accessory Outlet, 12V,  
 Adjustable Armrest/Console, (fore/aft sliding)  
 Air Conditioner/Heater/Pressurizer  
 AM/FM/CD/WB radio with AUX input  
 Ashtray  
 Cab Dome Lamps (2)  
 Cigarette Lighter, 24V

Coat Hook  
 Cup Holder (2)  
 Floormat, Sweep-out  
 Retractable seat belt (3 inch)  
 ROPS/FOPS Certified  
 Seat, Air Suspension, fabric  
 Steering Column, Telescoping and Tilting w/quick-release pedal  
 Storage Box (Heated/Cooled)  
 Storage Tray  
 Sun Visor

### Alarms, Gauges and Indicators

Alarms(Visual & Audible)  
 Air cleaner element  
 Axle oil temperature  
 Battery discharge warning  
 Boost temperature/ Boost temperature difference  
 Brake oil low pressure  
 EGR gas temperature  
 Engine oil low pressure  
 Engine warning  
 Fuel temperature  
 Fuel filter (Plugged Filter)  
 Fuel filter (Water in fuel)  
 Hydraulic oil level  
 Hydraulic oil temperature  
 Intake Air temperature  
 Main pump oil pressure  
 Overheat (Engine coolant)  
 Transmission warning  
 Gauges  
 Brake oil pressure  
 Engine coolant temperature  
 Fuel gauge

Speedometer  
 Tachometer  
 Transmission oil temperature  
 Indicators  
 Air conditioner display  
 Boom Kick-Out, Dual  
 Cold Start  
 Control lever lock  
 Declutch  
 Fan reverse rotation  
 F-N-R Selection  
 F-N-R Switch Enable  
 High beam  
 ECO-Operating Status  
 Work mode (Normal, Power)  
 Parking brake  
 Shift hold  
 Time/Operating hour/ODO  
 Transmission mode and status  
 Turn signal w/4-way flashers/Marker  
 Work light

### Others

Articulation locking bar  
 Counterweight  
 Drawbar  
 Fenders, Front, w mudflap  
 Fenders, Rear, Deck-type, w mudflap  
 Ladders, Inclined  
 Lifting eyes

Linkage Pins, HN Bushing  
 Neutral Safety Start  
 Rear Grill, hinged  
 Steps, rear  
 Vandalism protection  
 Z-bar loader linkage

## OPTIONAL EQUIPMENT

Autolube  
 Belly Guard, Transmission  
 Bolt-On Cutting Edge & Segments  
 Bucket Teeth  
 Camera, Rear View

Counterweight, Optional  
 Dual Lever Hydraulic Control  
 Fenders, Rear, Full, w mudflap  
 HID Work Lights  
 High Lift Boom Arm

Hydraulic System, 3 Spool Valve  
 LED Work Lights  
 Pre-cleaner (turbine type)  
 Quick Coupler & Attachments

Quick Coupler, Full Cast  
 Ride Control, Automatic  
 Seat, Heated  
 Secondary Steering

# ONE FOCUS. COMPLETE SOLUTIONS.

## THE KAWASAKI DIFFERENCE

It's the Kawasaki difference customers across North America look to — power, performance, reliability and a rich history of providing innovative solutions. Through its long-term commitment to maintaining a leadership position in technology, service and support, dedicated focus on a single product line and unsurpassed track record, Kawasaki continues to deliver. This means real benefits to your business: efficiency, increased production, reduced operating costs, comfort and across-the-board quality support.

- Dedicated Focus on Producing Wheel Loaders Since 1962
- Engineered Specialty Applications Packages
- Extensive Training at the KCMA Corporation Training Center and at Customer and Dealer Locations
- Flexible Warranty Programs
- Fully Equipped, in-house Rebuild Center
- 24-Hour Parts Shipments
- Carefully Designed Programs and Services

- Solid Partnerships with Knowledgeable, Experienced, Independent Dealers

## HISTORY

KCMA's parent company, Kawasaki Heavy Industries, has been a global leader for more than 100 years at providing comprehensive solutions and quality, top-performing products. From aerospace to infrastructure to construction equipment, Kawasaki Heavy Industries sets the standard — all the while raising the bar.

## FOCUS

Thanks to Kawasaki's total focus on articulated wheel loaders, your Kawasaki wheel loader is ready to tackle the most demanding applications and environments.

Even more, KCMA's fully equipped rebuild center, located in Kennesaw, Georgia, goes steps further by staffing skilled technicians armed with the in-depth knowledge and specialized equipment required to provide customers with first-class support.



## INNOVATION

Working with end users across the globe, KCM engineers stay up to speed on reviewing wheel loader needs. The result: Kawasaki leads the way in responding to new industry demands with complete solutions, engineering and manufacturing Kawasaki wheel loaders that are up to the task — and your expectations.

## KAWASAKI WHEEL LOADERS

- 15 Models
- .78–13.5 cu.yd.
- 45 HP–720 HP



**KCM**  
KCMA Corporation

2140 Barrett Park Drive • Suite 101  
Kennesaw, Georgia 30144  
[www.Kawasakiloaders.com](http://www.Kawasakiloaders.com)  
Tel: 770-499-7000  
Fax: 770-421-6842

Part# 70Z7 BROCH (10/2013)