

50/345

Articulating Crane



► 50/345 Articulating Crane

IMT® 50/345 articulating cranes feature hexagonal booms for greater strength and stability while providing a maximum horizontal boom reach of 70 ft (21.4 m) and a max lifting capacity of 22,840 lb (10,360 kg). That's a lot of lifting power for articulating cranes that require minimal mounting space and offer the versatility to maneuver around difficult job sites.

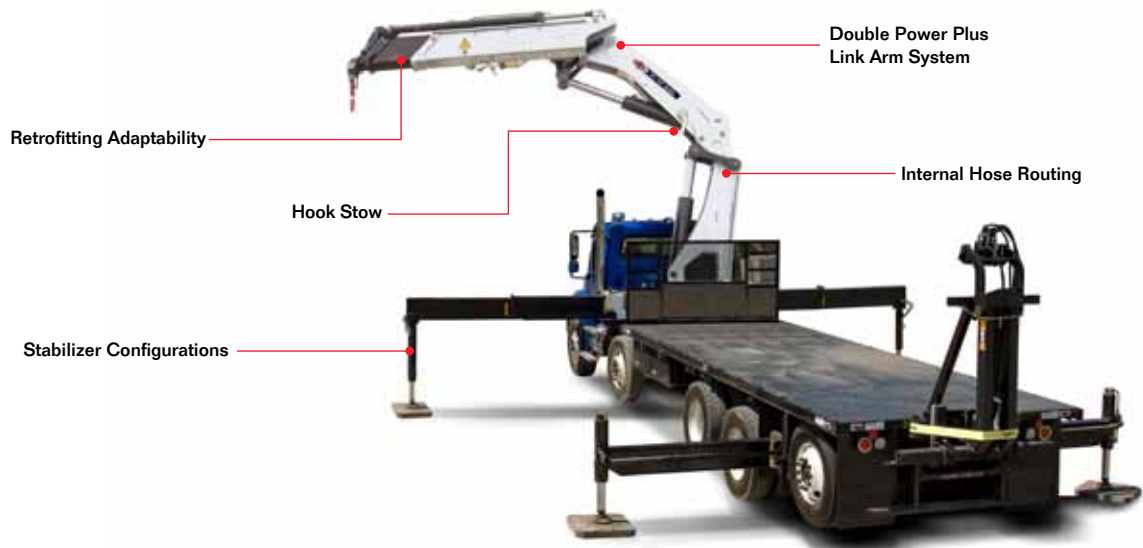

50/345 Specifications

	2 - Hydraulic	3 - Hydraulic	4 - Hydraulic	5 - Hydraulic
Crane Rating*	345,015 ft-lb (47.7 tm)	334,165 ft-lb (46.2 tm)	331,995 ft-lb (45.9 tm)	323,315 ft-lb (44.7 tm)
Max Horizontal Reach	26' 11" (8.2 m)	33' 6" (10.2 m)	40' 4" (12.3 m)	47' 3" (14.4 m)
Max Vertical Reach	35' 4" (10.8 m)	42' 4" (12.9 m)	49' (15 m)	56' 3" (17.1 m)
Max Capacity	22,840 lb (10,360 kg)	22,155 lb (10,050 kg)	21,540 lb (9770 kg)	20,965 lb (9510 kg)
Max Cap @ Max Reach	12,675 lb (5750 kg)	9680 lb (4390 kg)	7585 lb (3440 kg)	5975 lb (2710 kg)
Crane Weight **	8180 lb (3710 kg)	8820 lb (4000 kg)	9415 lb (4270 kg)	9965 lb (4520 kg)
Hook Approach				
Vertical	9' 5" (2.9 m)	9' 1" (2.8 m)	8' 11" (2.7 m)	8' 9" (2.7 m)
Horizontal	3' 11" (1.2 m)	4' 1" (1.2 m)	4' 3" (1.3 m)	4' 5" (1.4 m)

Center of Gravity - Stored

Vertical	3' 1" (92.7 cm)	3' 1" (92.7 cm)	3' 2" (94.5 cm)	3' 2" (94.5 cm)
Horizontal (C/L Rotation to Bridge)	14.5" (36.8 cm)	14.5" (36.8 cm)	14.3" (36.3 cm)	14.1" (35.8 cm)

	6 - Hydraulic	7 - Hydraulic	8 - Hydraulic
Crane Rating*	315,360 ft-lb (43.6 tm)	313,910 ft-lb (43.4 tm)	306,680 ft-lb (42.4 tm)
Max Horizontal Reach	54' 9" (16.7 m)	62' 4" (19 m)	70' 3" (21.4 m)
Max Vertical Reach	63' 2" (19.3 m)	71' 2" (21.7 m)	78' 11" (24.1 m)
Max Capacity	20,435 lb (9270 kg)	19,930 lb (9040 kg)	19,490 lb (8840 kg)
Max Cap @ Max Reach	4740 lb (2150 kg)	3815 lb (1730 kg)	3085 lb (1400 kg)
Crane Weight **	10,405 lb (4720 kg)	10,805 lb (4900 kg)	11,190 lb (5075 kg)
Hook Approach			
Vertical	8' 7" (2.6 m)	8' 5" (2.6 m)	8' 3" (2.5 m)
Horizontal	4' 7" (1.4 m)	4' 9" (1.5 m)	4' 11" (1.5 m)

Center of Gravity - Stored

Vertical	3' 2" (94.5 cm)	3' 3" (97.5 cm)	3' 3" (97.5 cm)
Horizontal (C/L Rotation to Bridge)	13.9" (35.3 cm)	13.7" (34.8 cm)	13.5" (34.3 cm)

* Crane rating (ft-lb) is the rated load (lb) multiplied by the respective distance (ft) from centerline of rotation with all extensions retracted and the inner and outer booms in a horizontal position, per ANSI B30.22. ** Crane weight is for standard crane with tank & 8-bolt long mounting kit. Does not include stabilizers, tank or oil.

Standard Features

- Radio remote control
- Double link arm system
- Application-specific product offering
- Superior lift-to-weight ratio
- Long-reach capabilities
- Hexagonal booms for superior reach and maximum control
- Internal hose routing
- 15° overbending on outer boom

Options

- Various stabilizer configurations
- Boom mounted winch
- Floodlight on outer boom
- Boom tip functions for hydraulic attachments
- Oil cooler

Specifications

Stabilizer Pad Diameter	8" (20.3 cm)
Crane Storage Height	7' 10" (2.4 m)
Mounting Space***	3' 11" (1.2 m)
Rotational Torque	36,880 ft-lb (5.1 tm)
Rotation	Infinite
Optimum Pump Performance	21.1 gpm (80 L/min)
System Pressure	5295 psi (365 bar)
Oil Reservoir Capacity	66 gal (250 L)
Stabilizer Extension Span	
Minimum (2 beams - 64" [162.6 cm] long)	18' 3" (5.6 m)
Maximum (2 beams - 108" [274.3 cm] long)	25' 6" (7.8 m)
Stabilizer Weights	
Stabilizer Beam 64" (162.6 cm)	410 lb (185 kg)
Stabilizer Beam 81" (205.8 cm)	630 lb (285 kg)
Stabilizer Beam 108" (274.3 cm)	685 lb (310 kg)
Stabilizer Cylinder, 1x swing-up	145 lb (65 kg)
Stabilizer Cylinder, 1x hydraulic swing-up	160 lb (72 kg)

*** Maximum swing clearance radius required is 29" (73.7 cm) at 8' 6" (2.6 m) from top of chassis frame

Minimum Chassis Specifications

Front Axle Rating (GAWR)	20,000 lb (9070 kg)
Rear Axle Rating (GAWR)	46,000 lb (20,865 kg)
Resistance to Bending Moment Minimum	5,175,000 in-lb (596,224 kg-m)

Hexagonal Boom Design

A wide hexagonal profile with large bearing surfaces ensures greater strength and stability for horizontal and vertical spans — even when working in extreme positions with long reaches. Plus, it's protected by powdercoat paint that never fades, flakes, or corrodes.



Internal Hose Routing

Fed internally through protective nylon drag chains or roller guides, all hoses are equipped with sturdy, high-pressure swivel couplings to prevent them from twisting.



Overbending

Overbending between the main boom and jib provides greater flexibility when working under power wires and more potential for high lifting in narrow passages. It also lowers the total height when the loader is stowed over the truck body.



Stow Bracket Innovation

The stow bracket is designed to secure the boom for transport position but not allow for bracket damage. Unlike systems with rigid fixed brackets, the "J" hook will pivot if an incorrect movement is attempted.

► 50/345 Capacity Charts

50/345 K2

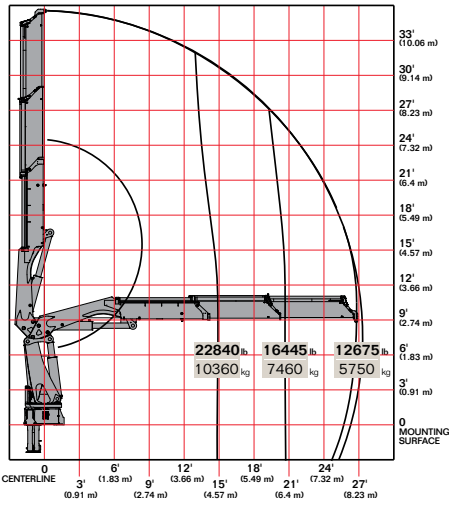

50/345 K3

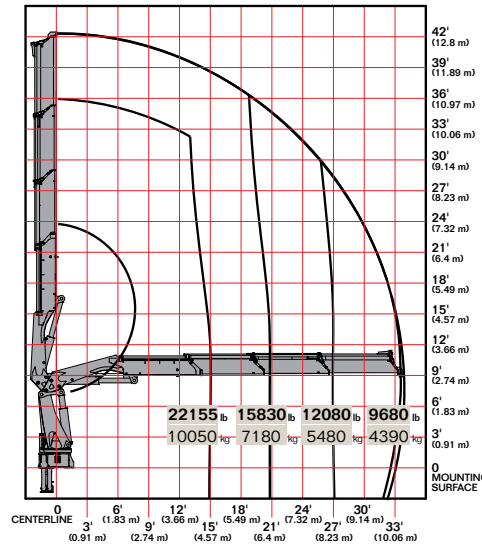

50/345 K4

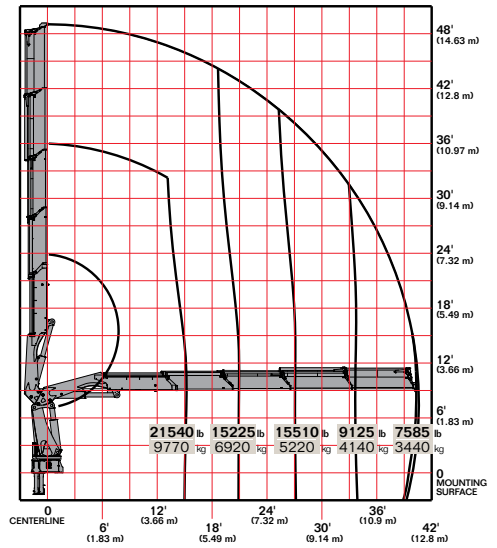

50/345 K5

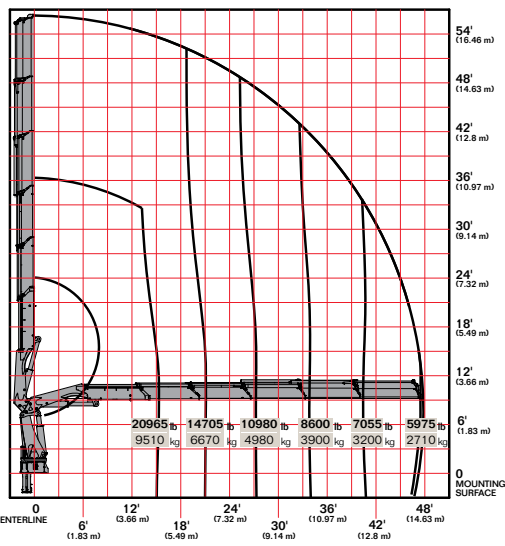

50/345 K6

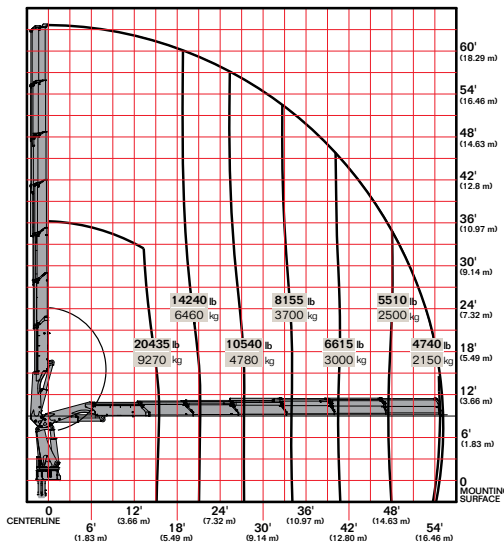

50/345 K7

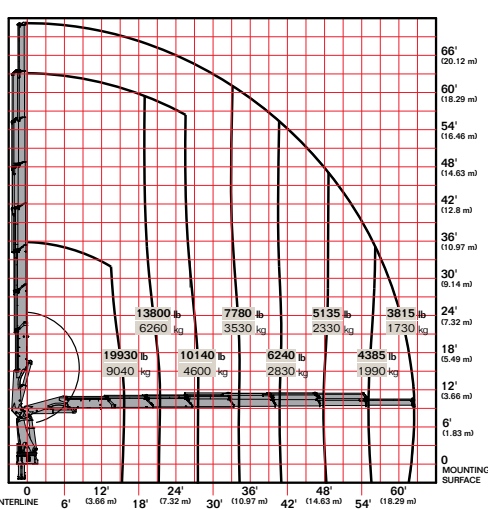

50/345 K8

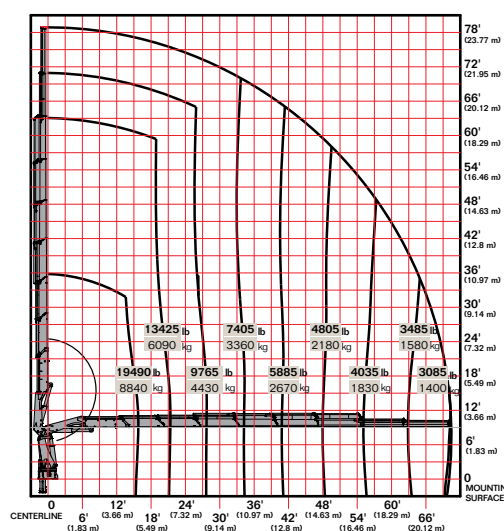

Limit working loads to those shown. Deduct the weight of load-handling devices.

► 50/345 Lifting Capacity

50/345 - 2 Hydraulic

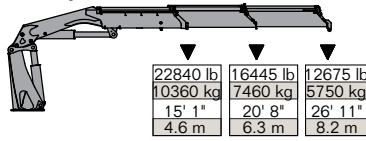

50/345 - 3 Hydraulic

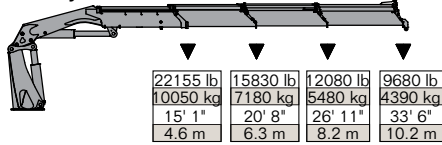

50/345 - 4 Hydraulic

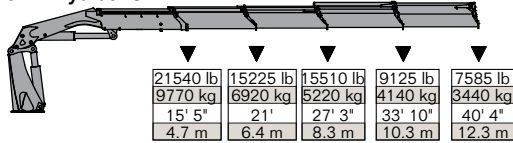

50/345 - 5 Hydraulic

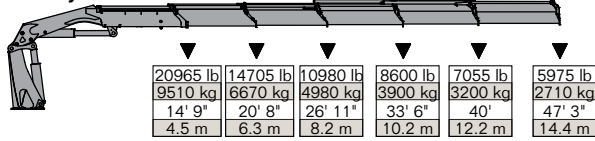

50/345 - 6 Hydraulic

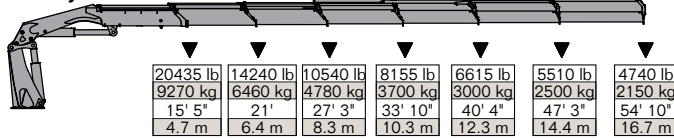

50/345 - 7 Hydraulic

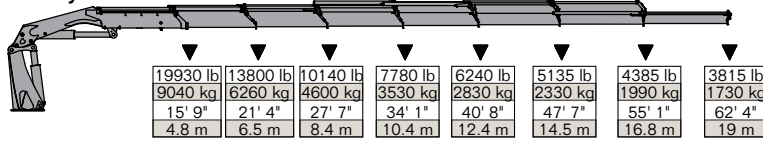

50/345 - 8 Hydraulic

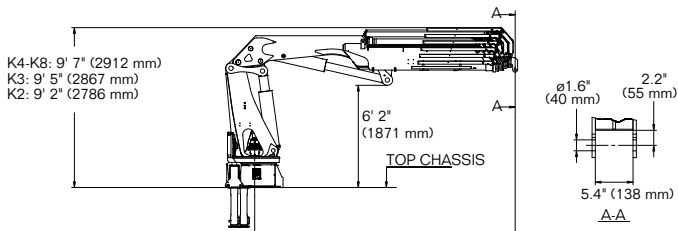
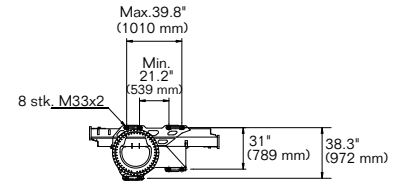
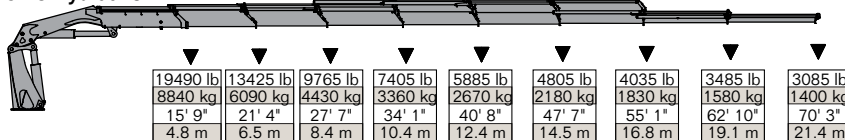

- K8: 15' 11" (4860 mm) max. 70' 7" (21,510 mm)
- K7: 15' 10" (4817 mm) max. 62' 10" (19,140 mm)
- K6: 15' 8" (4770 mm) max. 55' 2" (16,820 mm)
- K5: 15' 6" (4720 mm) max. 47' 5" (14,450 mm)
- K4: 15' 4" (4680 mm) max. 40' 6" (12,350 mm)
- K3: 15' 3" (4640 mm) max. 33' 10" (10,310 mm)
- K2: 15' (4560 mm) max. 27' 2" (8270 mm)

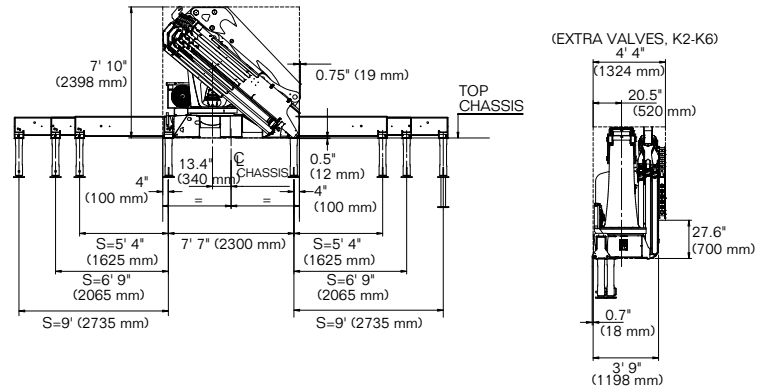

Power Source

- Standard integral-mounted piston hydraulic pump and PTO application

Cylinder Holding Valves

- Integral-mounted counterbalance valves or load-holding check valves
- Prevention of sudden cylinder collapse in case of hose failure

Rotation System

- 360 degree continuous rotation through planetary gear box
- 29,500 ft-lb (4.1 tm) rotational high-torque hydraulic motor
- Hydraulic brake included

Hydraulic System

- Open-centered system — closed optional
- Regeneration system on extension cylinder to ensure quick deployment
- Hydraulic oil reservoir, air breather, replaceable return-line filter, and control valve with levers

Overload System

- Load-limiting capability for boom functions
- Rated capacity limitation (RCL) 5300 blocks load-increasing functions when full capacity is attained



Nothing Says Commitment Like The Diamond.™

IMT has been meeting the needs of our customers for over 50 years and none of it would have been possible without a distributor network that's second to none. IMT distributors offer fast, knowledgeable service and the ability to help customers find the right product for every application. When you're looking for reliable equipment and dependable service, remember IMT.



An Oshkosh Corporation Company

Iowa Mold Tooling Co., Inc.
500 Highway 18 West
Garner, Iowa 50438
800-247-5958 • www.imt.com