

# Quest Oil-Fired CHH-300

## Installation, Operation and Maintenance Instructions

– Read and Save These Instructions –



### **! WARNING**

This appliance is equipped with a Blocked-Flue shutoff device. If any part of the flue-gas passageway in the combustion chamber, exhaust pipe or rain cap should become blocked or adversely restricted, a pressure sensing switch (Fig.24 pg.10) will break the electrical control circuit and not allow the burner to run. There is a “Manual Reset” button on this switch that will have to be reset before re-firing can occur. If the burner fails to start after resetting once, call a qualified service technician to clean the flue passageways and/or replace the switch. Cleaning instructions can be found in Section (6.1 G) of the Maintenance section of this manual.



Intertek  
3103897



**Therma-Stor<sup>®</sup> LLC**  
Driven by performance. Powered by design.™

4201 Lien Rd.  
Madison, WI 53704  
[www.QuestProtect.com](http://www.QuestProtect.com)

Phone 608-237-8400  
Toll-Free 1-866-413-5214  
[sales@QuestProtect.com](mailto:sales@QuestProtect.com)



# Quest Oil Fired CHH-300 Installation, Operation and Maintenance Instructions

Table of Contents	Page
1. System Description & Features .....	3
1.1 Description .....	3
1.2 Features .....	3
2. Safety .....	4
2.1 General Safety Guidelines.....	4
2.2 Safety Devices and Clearances .....	5
2.3 Heat Transfer Fluid .....	5
3. Specifications.....	5
3.1 Construction Specifications.....	5
3.2 Dimensions & Capacities Chart.....	6
3.3 Oil Burner & Fuel Specifications .....	6
3.4 Circulation Pump.....	7
3.5 Electrical Requirements for Complete System.....	8
3.6 Gauges & Indicator Lights .....	8
3.7 Controls & Electrical .....	9
3.8 Control, Switch, & Gauge Identification .....	10
4. Setup.....	12
4.1 Positioning Equipment on the job.....	12
4.2 Hose & Accessory Connections.....	12
4.3 Charging the Fluid System.....	14
4.4 Oil Burner Installation & Setup.....	15
5. Operation.....	15
5.1 Startup .....	15
5.2 Shutdown.....	16
6. Maintenance .....	17
6.1 Service Instructions & Checks .....	17
6.2 Maintenance Frequency Chart.....	20
7. Troubleshooting .....	21
7.1 Fault Determination .....	21
7.2 Burner Internal Faults .....	23
7.3 Electrical Schematics.....	24
Warranty .....	27

Serial No. \_\_\_\_\_

Purchase Date \_\_\_\_\_

Dealer's Name \_\_\_\_\_



## 1. System Description & Features



1: CHH-300, Pump End



2: CHH-300, Burner End

### 1.1 Description

- The CHH is a fuel burning appliance, designed to heat fluid “on demand” and provide pumped circulation of the fluid for use in various portable hydronic applications.
- The CHH provides a central source of hot “heat transfer fluid” (HTF) for use with dependent heat exchangers such as:
  - Fan coils for heating and drying of structures.
  - Multi-circuit line heat exchange hose or tubing for ground thawing, concrete curing, snow melting and slab heating.
  - Custom hydronic heat exchange accessories and applications.
- CHH oil-fired units are designed to burn #1 or #2 light diesel fuel or heating oil.
- Pumping and combustion control are achieved with electrical components. The CHH-300 requires a 120 volt, 20 amp, 3-wire grounding circuit.
- The CHH is designed for consistently-efficient outdoor operation.

### 1.2 Features

- All exposed components are made of non-corrosive materials such as stainless steel, brass or aluminum.
- The “HTF” circuit includes an open, atmospherically-vented expansion tank, which effectively eliminates the system from pressure vessel classification.



- The control system includes a sequence of status indicator lights which provide a quick function check and trouble-shooting aid for the operator.
- The combustion chamber/heat exchanger is completely fabricated from stainless steel and is not susceptible to corrosion. Temperature turn-down for prolonged periods of operation (such as for concrete curing) will not harm the chamber.
- For security and environmental protection, all valves, controls, burner, pump, filters, "HTF" tank filler and fuel tank filler are either secured behind lockable access doors or are self-lockable.
- An optional stainless steel diesel-fuel tank is available for the CHH-300 or it can be connected to a suitable user-provided fuel tank.
- An electric "Pre-heater" ensures continued clean lighting and combustion of diesel/light oil, even in the coldest of climatic conditions.
- Temperature gauges, pressure gauge, system status indicator lights, "HTF" tank level gauge and fuel tank level gauge are visible to the operator even when the system is securely locked down.
- The CSA/UL approved burner, comes with a permanently installed pressure gauge to simplify adjustment of fuel pressure when setting up the burner.
- Door handles and hose connection couplers for the external HTF circuit are recessed so as not to create "snag-points" when moving, shipping or delivering the unit.

## 2. Safety

### CAUTION

#### 2.1 General Safety Guidelines:

##### **CAUTION! This is a fuel burning appliance.**

- Some surfaces will become **EXTREMELY HOT!**
- When using the fuel oil **the chance of FIRE or EXPLOSION always exists!** Always follow safe-operating practices and comply with local fire and fuel handling codes.
- Before attempting to setup or operate this equipment, it is imperative that the operator reads and understands all the information in this manual.
- Untrained people should not attempt to operate this equipment until they receive proper instruction.
- Maintain instructional and safety labels. Replace damaged labels.
- Observe all posted warnings and cautions.
- Always wear suitable protective clothing and accessories such as safety glasses, leather gloves, certified work boots and hard hat when working with or operating this equipment.
- Keep children, pets and all untrained bystanders clear from the heater and accessories.



## 2.2 Safety Devices and Clearances

- All safety devices must be in place and functioning properly when the equipment is in operation.
- All hydronic heater panels and doors must be kept closed when the system is operating.
- The flue-gas exhaust pipe and rain-cap requires a minimum of 6" (152 mm) clearance, from any type of combustible material.
- Clearance from any obstructive objects must be maintained to a minimum of 36" (914 mm) from both ends of the Hydronic Heater.
- Do not allow anything to obstruct the "combustion air intake".

## 2.3 Heat Transfer Fluid

**Precautions and measures to follow when working with "heat transfer fluid" (Inhibited aqueous propylene glycol).**

- Ventilation - Good general ventilation should be sufficient for most conditions.
- Respiratory protection - No respiratory protection should be needed.
- Skin protection - For brief contact, no precautions other than clean body-covering clothing should be needed.
- Use impervious gloves when prolonged or frequently repeated contact should occur.
- Eye protection - Use safety glasses.

### **First aid measures.**

- Eyes - Flush eyes with plenty of water.
- Skin - Wash off in flowing water or shower.
- Ingestion - Induce vomiting if large amounts are ingested. Consult medical personnel.
- Inhalation - Remove to fresh air if effects occur. Consult a physician.
- Note to physician - No specific antidote. Supportive care. Treatment based on judgement of the physician in response to reactions of the patient.

## 3 Specifications

### 3.1 Construction Specifications

- The "CHH" includes an aluminum "enviro-containment" base, with fork-lift pockets.
- The exterior enclosure panels are made of stainless steel.
- The framework for the enclosure and the base are built of structural aluminum. A top center hoisting hook is included.
- Primary access for operation and service is provided for through hinged, lockable doors at the two ends of the enclosure.



# Quest Oil Fired CHH-300 Installation, Operation and Maintenance Instructions

- Both side panels and both roof panels are fastener-attached for potential removal.
- Then combustion chamber/heat exchange section is fabricated from stainless steel.
- Access for cleaning the chamber is from the burner end with minimal disassembly required. The procedure consists of removing the burner and inside chamber section.
- Temperature turn-down and condensing within the chamber can not harm the chamber.
- The exhaust flue for the burner exits through the roof of the enclosure. The exposed roof flashing is made from aluminum. The rain cap and flue pipe are made of stainless steel.

## 3.2 Dimensions and Capacities

Length of Cabinet	inches (millimeters)	72 (1829)
Width of Cabinet	inches (millimeters)	22 (559)
Width with Fuel Tank	inches (millimeters)	31 (787)
Height of Cabinet	inches (millimeters)	48 (1219)
Height to Top of Rain Cap	inches (millimeters)	58 (1473)
Heat Transfer Fluid Capacity	US gallons (liters)	20 (76)
Fuel Tank Capacity	US gallons (liters)	116 (439)
Weight without Fuel Tank	pounds (kilograms)	600 (272)
Weight with Fuel Tank Empty	pounds (kilograms)	800 (363)
Weight with Fuel Tank Full	pounds (kilograms)	1700 (771)

## 3.3 Oil Burner and Fuel Specifications (Fig. 3)

- The “oil burner” is a pressure-atomization type with direct spark ignition manufactured by Riello Burners.
- #1 or #2 light heating oil or diesel fuel may be used.
- A gauge is connected to a pressure-tap port on the fuel pump of the burner to aid in setting the burner and monitoring performance (Fig. 26).
- A fuel filter is mounted inside the enclosure (Fig.5).
- Supply and return fuel lines are equipped with quick couplers for ease of connection to a fuel tank.
- An optional “diesel fuel pre-heater” (Fig. 6) is available for use in cold climate areas where winter temperatures get down to levels that could cause diesel fuel to gel. This fuel heater clips around the fuel filter and connects to a 120V outlet in the control panel. A built-in thermostat maintains the temperature of fuel flowing through the filter at around room temperature.

Riello Burner Model	Light Oil	40-F10
Operational Mode		single stage
Electrical Characteristics	V / A / Hz / Ph	120 / 2.0 / 60 / 1
Nozzle: Delavan Part #		1.65-60 <sup>o</sup> B
Fuel Pump Pressure: factory setting	PSI (kilopascals)	180 (1241)
Turbulator Head: factory setting	#	3.0
Air Gate: factory setting	#	4.2
Fuel Input Rate: factory set	USGPH (liters/Hr)	2.2 (8.3)
Heat Input: based on 140,000 Btu per USG	Btu/H (Watts)	308,000 (90,244)
Heat Output @ 80% net efficiency	Btu/H (Watts)	246,400 (72,195)



# Quest Oil Fired CHH-300 Installation, Operation and Maintenance Instructions



**3: Oil/Diesel Burner**



**4: Fuel Filter & Valve**



**5: Diesel Fuel Heater**

## 3.4 Circulation Pump (Fig. 6)

- The HTF circulation pump is a stainless steel, direct drive centrifugal type.
- The pump is located inside the enclosure at the opposite end of the burner and can be accessed through a hinged lockable door (Fig. 1).
- A panel-mounted pressure gauge is connected to the output side of the HTF pump by means of a 1/8" ID hydraulic hose and fittings (Fig. 25).

Goulds Pump Model		1ST1E4C4
Impeller Diameter	inches (millimeters)	5.1875 (132)
Motor Horsepower	HP (Watts)	1.0 (746)
Voltages pump can run on	Volts	120/240
Full Load Amp Rating - Franklin motor	Amps	10.4/5.2
- Emerson motor	Amps	12.3/6.2
System Design Flow Rate	USGPM (liters/sec)	30 (1.89)
System Design Operating Pressure	PSI (kilopascals)	35 (241)



**6: Fluid circulation Pump**

## 3.5 Electrical Requirements for Complete System

Supply Voltage	Volts	120
Circuit Amperage	Amps	20
Hertz	HZ	60
Phase	PH	single-
Control Circuit Voltage	Volts	120
Power Inlet - NEMA Twistlock		L5-20P



7: Power Inlet Plug

## 3.6 Gauges and Indicator Lights

- A cluster of gauges and status-indicator lights are located inside the UL approved control panel. This panel is located behind the burner access door near the top (Fig. 2). These gauges and lights are visible from the exterior through plexi-glass windows in the access door and the control panel door.
- A digital gauge (Fig. 14) monitors each of the following:
  - HTF supply temperature.
  - HTF return temperature.
- A digital hours meter (Fig. 14) logs system run-time.
- A series of 6, LED indicator lights (Fig. 15) illuminate in sequence as each of the following scenarios is proven:
  - #1 - 120 volt control power is present - clear lens.
  - #2 - HTF level is adequate in reservoir - green lens.
  - #3 - Auto reset high temp switch has not interrupted the circuit - green lens.
  - #4 - High limit control has not interrupted the circuit - green lens.
  - #5 - High pressure switch has not interrupted the circuit - green lens.
  - #6 - Aquastat is calling for heat - green lens.





**8: Control Panel, Outer**



**9: Control Panel, Inner**

## 3.7 Controls and Electrical

- The UL approved electrical box, located inside the enclosure, above the burner, houses specific electrical components, besides the lights and gauges, and serves as a junction box for cords going to and from remote electrical components (Fig. 8 & Fig. 9).
- The following components are part of and are located in the UL approved box:
  - Main power disconnect (Fig. 11).
  - Pump ON/OFF switch (Fig. 12).
  - Burner circuit ON/OFF switch (Fig. 13).
  - Main system breaker (Fig. 16).
  - Pump circuit breaker (Fig. 16).
  - Burner circuit breaker (Fig. 16).
  - Power disconnect switch (Fig. 17).
  - Temperature gauge transformers 6VDC (Fig. 18).
  - LED lights - 120 volt (Fig. 15).
  - Hours meter - 120 volt (Fig. 14).
  - Terminal blocks (Fig. 20).
  - Contactors (Fig. 19).
  - Electronic operating controller (Fig. 10).
- The following items are remotely connected to cords that exit from the control panel: (see chart below for details of these components)
  - Main power male inlet-plug (twist lock) (Fig. 7).
  - Low water cut-off switch (mounted on HTF reservoir) (Fig. 21).
  - High Temp Auto switch (mounted in HTF plumbing circuit).
  - High Temp Limit switch (mounted in HTF plumbing circuit) (Fig. 23).

- High pressure switch (Fig. 24).
- Diesel fuel pre-heater (Fig. 5).
- HTF circulating pump (Fig. 6). (see pump chart above for details)
- Burner (Fig. 3). (see burner chart above for details)

## 3.8 Control, Switch & Gauge Identification

- Mounted on Control Panel



10: Operator, Digital



11: Main Power Switch Knob



12: Pump Switch



13: Burner Switch



14: Temperature Gauges & Hour Meter

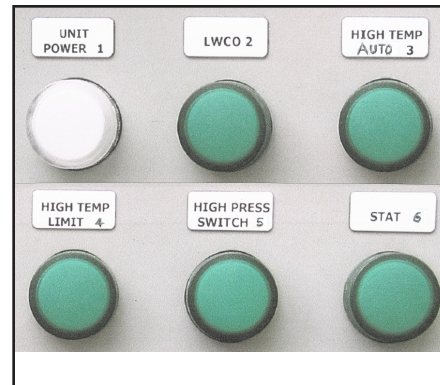

15: LED Indicator Lights

# Quest Oil Fired CHH-300 Installation, Operation and Maintenance Instructions

- Mounted Behind Control Panel



16: Circuit Breakers



17: Main Power Switch Body



18: Transformers for Digital Temp. Gauges

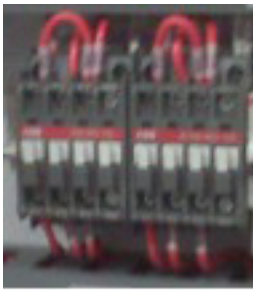

19: Contactors



20: Terminal Blocks

- Mounted Remotely on Plumbing Circuit



21: Low Water Cutoff



22: Auto High Temp Switch



23: High Temp Limit Switch



24: High Pressure Switch

- Pump and Burner Pressure Gauges



25: Pump Pressure Gauge (PSI)



26: Fuel Oil Pressure Gauge (PSI)

## 4. Setup

### 4.1 Positioning Equipment on the Job

Before choosing the location to place the central hydronic heater on a job site, several factors should be considered.

- If possible, the CHH should be placed at a central position that will minimize and equalize the lengths of hoses. This helps to ensure maximized and equalized HTF flow.
- Convenient access to a suitable electrical connection, if site power is to be used. 120V, 1PH, 60Hz, 20A, 3-wire grounding is required.
- Convenient access to bulk truck re-fueling.
- Do not locate in the path of job site traffic.
- Avoid locations that will expose the CHH to intense dust or other sources of air contamination. Clean flowing air is essential to maintain clean combustion.
- Observe all requirements listed in the “Instructions for Installation” document provided with this unit.

### 4.2 Hose and Accessory Connections

In order to make use of the heated fluid, it is necessary to lay out a circuit of hoses to; distribute the hot fluid, transfer it's heat to another medium and return the cooled fluid to the CHH for re-heating (Fig. 27).

- Primary 1” hoses are used from the CHH quick-connect couplings (Fig. 28) to feed a manifold for either multiple fancoils in air heating situations (Fig. 30) or multiple 5/8” hose circuits for ground thawing, concrete curing, slab heating or snow melting (Fig. 31).
- Use only “approved hose” as supplied by ThermaStor. Otherwise, compatibility issues may arise.
- Hoses are pre-charged with the recommended mixture of water and propylene glycol and are equipped with hydraulic-style quick couplers. Every hose has a male connector on one end and a female connector on the other end; therefore any hose can be used for either the supply side or the return side of the hose circuit.
- Route hoses to achieve minimum chance of damage from traffic of any kind and at the same time minimize the overall circuit length.
- Provide protection from “Kinking” of hoses that would restrict flow.
- When connecting Quick couplers, ensure that the connections are “fully engaged” and snapped into place or flow will not take place through the coupler connection.
- For longer term, building heating projects it is advised to insulate all hose sections located outdoors, between the CHH-300 and the exterior building wall. Special “insulating wraps” are available for this purpose.



## Quest Oil Fired CHH-300 Installation, Operation and Maintenance Instructions

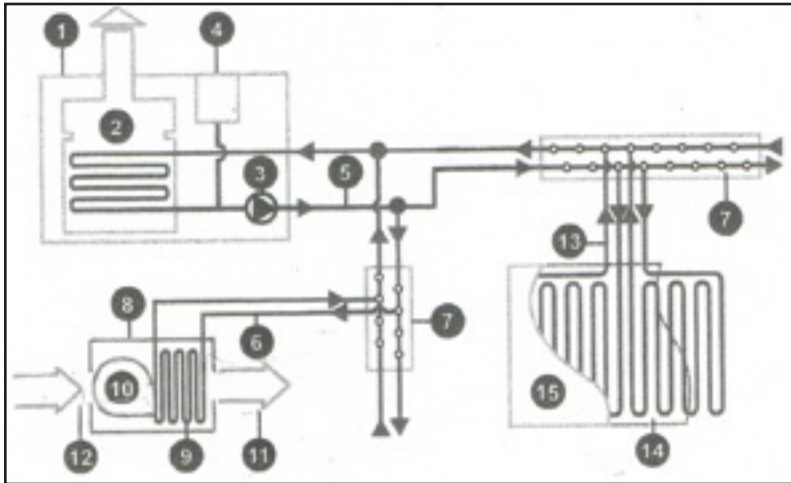

27: Layout for Fluid Distribution

1. Central Hydronic Heating Unit
2. Burner & Heat Exchanger
3. Circulating Pump
4. Reservoir for Expansion & Filling
5. Primary Fluid Hoses, 1"
6. Secondary Fluid Hoses, 3/4" or 1"
7. Manifold for Multiple Connections
8. Fancoil Heat Exchanger
9. Heat Transfer Coil
10. Air Moving Fan
11. Heated Supply Air
12. Intake Air
13. Hose Grid Line Heat Exchanger 5/8"
14. Vapor Barrier
15. Insulated Tarps



# Quest Oil Fired CHH-300 Installation, Operation and Maintenance Instructions



28: Hoses Connected to CHH Unit



29: Fancoil Connected to CHH Unit

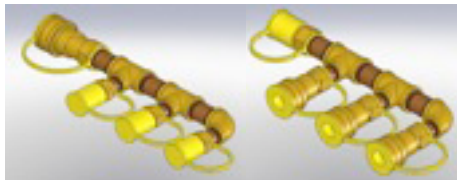

30: Manifolds for Fancoils - Supply & Return

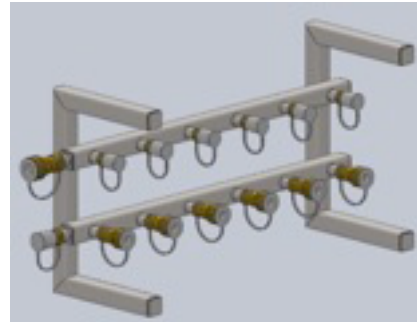

31: Manifold for Thaw & Cure

## 4.3 Charging the Fluid System



32: HTF Level Gauge & Vented Filler Cap



33: HTF Circuit Valves, Y-strainer & High Temp. Limit

- The CHH-300, all hose and all accessories are shipped pre-charged with the “approved blend” of heat transfer fluid (HTF). The required fluid is a 50% blend of Inhibited propylene glycol and de-mineralized neutral PH (#7)water. This provides freeze protection to -29°F (-34°C). The HTF provided with a new system and accessories is marketed as DowFrost. Use of any other product that cannot be proven to be equal in all respects will void warranty of the system.

# Quest Oil Fired CHH-300 Installation, Operation and Maintenance Instructions

- Check the HTF level gauge (Fig. 32). The reservoir should be 1/4 to 1/2 full when the system is cold. Add approved fluid, if necessary, at the vented filler cap (Fig. 32).
- Connect all primary hoses from the CHH-300 to the distribution manifold.
- Place all fancoils in the desired locations and route all the hoses to them OR lay out all hose grid circuits for ground thaw or concrete curing.
- Connect hoses from the manifold to ONE fancoil or ONE thaw/cure loop ONLY.
- Open 2 HTF circuit valves (Fig. 33). Turn ON the circulating pump switch (Fig. 12) and let the fluid circulate until all the air is eliminated from the first branch circuit. Air has been purged when steady pressure of 30 to 35 PSI is observed at the glycol pressure gauge (Fig. 25).
- Connect each fancoil or thaw/cure loop, in turn, one at a time, in the same manner as above. When all are connected and the pressure gauge maintains steady pressure, the system is charged and ready for use.
- Check the HTF level again and top up if necessary 1/4 to 1/2 full).

## 4.4 Oil Burner Installation and Setup (Fig. 3)

- Refer to the Riello Burner 40-F10 manual (which is included with this package) for detailed information and instruction.
- Specific burner settings for the CHH-300 are as follows.

Riello Burner Model		40-F10
Nozzle: Delavan Part #		1.65-60°B
Fuel Pump Pressure: factory setting	PSI (kilopascals)	180 (1241)
Turbulator Head: factory setting	#	3.0
Air Gate: factory setting	#	4.2
Fuel Input Rate: factory set	USGPH (liters/Hr)	2.2 (8.3)
Heat Input: based on 140,000 Btu per USG	Btu/H (Watts)	308,000 (90,244)
Heat Output: @ 80% net efficiency	Btu/H (Watts)	246,400 (72,195)

## 5. Operation

### 5.1 Startup

- Make sure the CHH-300 is connected to a correct, stable power source (120V, 20A, 60Hz, 3-wire grounding) and proper gauge chords are used (12 gauge minimum).
- Verify adequate and correct fuel supply for the burner (#1 or #2 light oil or diesel). Open all valves in the fuel-supply lines.
- Make sure at least one circuit of HTF hose is connected to the CHH-300 to provide adequate fluid circulation (see hose and accessory connections section).
- At the control panel (Fig. 8), remove 2 thumb screws to open and expose the inner panel (Fig. 9), turn ON the three breakers located behind the light panel (Fig. 16). Close and refasten the panel.
- Turn ON the main power switch (Fig. 11). The white unit power light (Fig. 15) will come on, as well as the two digital temperature gauges and hour meter (Fig. 14).



- Turn ON the pump switch (Fig. 12) and check the pump pressure gauge (Fig. 25). Steady pressure around (30 to 35 PSI), indicates that no air remains in the fluid circuit.
- Once a stable pump pressure is achieved, turn ON the burner switch (Fig. 13). The following sequence should now occur: Observe the LED light cluster (Fig. 15).
  - The glycol level light will turn on (indicating that there is a sufficient amount of HTF in the system).
  - The high temp auto light will turn on. (This indicates that the high auto safety switch has not broken the circuit).
  - The high temp limit light will turn on. (This indicates that the high limit safety switches have not broken the circuit).
  - The high pressure limit switch light will turn on. (This indicates that the blocked flue high pressure safety switch has not broken the circuit).
  - A few seconds later, the stat light will come on and the burner fan will purge the combustion chamber for a few seconds.
  - The burner should light following the pre-purge. If air is still present in the fuel lines or filter, the burner may not light and lock out. It might be necessary to reset the burner module 2 or 3 times until fuel reaches the burner head and ignition takes place.
- Make sure the operator (Fig. 10) is set at the desired temperature. DO NOT operate at temperatures above 200°F, or damage to inline controls and certain accessory components can result. To adjust setpoint on this control just use the up and down key. There is no need to go into the menu of the control to perform this function. The control simultaneously displays setpoint temperature and actual supply fluid temperature.
- Once the setpoint temperature has been reached, the burner will cycle off and on as needed.

## 5.2 Shutdown

- Turn OFF the burner switch (Fig. 13). The burner will no longer recycle but the circulation pump will continue to run.
- It is recommended that the fluid be allowed to continue circulating until it has cooled down to 100°F (38°C) or lower.
- Turn OFF the pump switch (Fig. 12). If any fancoils and hoses have been placed at a higher elevation than the CHH-300, the primary hoses should be immediately disconnected from the CHH-300 (Fig. 28). This will prevent fluid from draining back and overflowing at the HTF reservoir vent (Fig. 32).
- Turn OFF the main power switch (Fig. 11).
- Turn OFF fuel supply valves.
- If the system is to be de-commissioned, it is now safe to disconnect the power supply and all HTF circulation hoses, manifolds and accessories.





## 6. Maintenance

### 6.1 Service Instructions and Checks

#### CAUTION

**“CAUTION: Label all wires prior to disconnection when servicing controls. Wiring errors can cause improper and dangerous operation. Verify proper operation after burner adjustment and servicing**

A. To achieve and ensure clean combustion from the burner, a “flue-gas analyzer” and “smoke spot tester” must be used to verify clean combustion. Perform the following checks while the burner is firing. Must be performed by a trained service technician ONLY. Refer to the Riello manual, 40-F10 for burner adjustment instructions. These checks should be performed, every time, when putting the system into operation on a new project and a minimum of once yearly.

- a. Before starting the burner, determine that the combustion head is set at 3.0 and the correct nozzle is in place (Delavan 1.65-60°B).
- b. Fire the burner and ensure that the oil pressure is at 180 PSI. Adjust if necessary.
- c. Regulation of combustion air flow is made by adjustment of the manual AIR ADJUSTMENT PLATE. Initial suggested setting is (4.2).
- d. Final position of the air adjustment plate must be set based on instrument readings of not greater than 13.0% CO<sub>2</sub> and a smoke spot reading of zero. Final readings must be taken with all service-access doors closed.

B. After placing this unit in operation, the ignition system safety shutoff device must be tested. Must be performed by a trained service technician ONLY. Refer to the Riello manual, 40-F10 for burner component identification and further instructions. This check should be performed, every time, when putting the system into operation on a new project or a minimum of once yearly.

- a. Shut OFF the “burner circuit” power switch.
- b. Remove the primary control box from the burner and place a small piece of dark tape over the light-sensing, cad-cell eye that senses the presence of flame in the combustion chamber. Put the primary control back in place.
- c. Turn the power switch back ON and initiate burner lighting procedure. After the short pre-purge cycle, the burner should light but go out in 5 seconds and lock out. If the burner does not lock out with the cad-cell eye covered, the primary control should be replaced.
- d. To put the unit back in standard operating mode, turn OFF the burner circuit power switch, remove the tape-cover from the burner’s primary control box, re-insert the control and turn ON the “burner circuit” power switch.

C. Examine the flue gas exhaust pipe and rain cap to be sure they are solidly attached and free from any type of obstruction. Clean if necessary.

- a. This check should be performed, every time, when putting the system into operation on a new project or a minimum of once yearly.

D. After placing this unit in operation, the low water safety shutoff device must be tested. Must be performed by a trained service technician ONLY. The low water cutoff switch is located in plain view at the same end of the CHH-300 as the circulating pump and is identified with a label.



## Quest Oil Fired CHH-300 Installation, Operation and Maintenance Instructions

- a. Push the test switch on the outside of the control. This will simulate a “low water” condition and open the burner circuit to prevent burner initiation.
  - b. By pushing the reset switch, the control will restore function to the burner circuit as long as there is fluid touching the probe. The electronic probe is a “self cleaning” type and should not require service.
  - c. This control should be tested every time, when putting the system into operation on a new project or a minimum of once yearly.
- E. After placing this unit in operation, the high temperature limit safety shutoff device must be tested. Must be performed by a trained service technician ONLY. Two high temperature limit switches are located in plain view at the same end of the CHH-300 as the circulating pump and are identified with labels. One of these switches re-sets itself automatically and is set at a slightly lower temperature (about 5°F) than the other which must be manually re-set after its set point has been reached.
- a. With the burner firing, set the main digital operating stat to a temperature value that is at least 5°F higher than the set point of the manual re-set high temperature limit switch.
  - b. When the fluid temperature reaches the set point of the automatic re-set limit switch, it should shut down the burner. As the fluid cools down 2 or 3 degrees, the burner should re-fire. This automatic re-set limit switch should function like a second thermostat and will take over as operator of the burner.
  - c. If you now adjust the set point of the automatic re-set limit switch to a level a few degrees higher than the set point of the manual re-set limit switch, the burner should continue to fire until the set point of the manual re-set high limit is reached. At this point the burner should be shut down and this time should not come back on as the fluid cools back down.
  - d. The manual re-set high limit will need to be manually re-set, by pushing the red re-set button. Adjust the operator back down to a normal operating lower setting and re-adjust the automatic high limit back down to its regular set point at about 5°F lower than the manual re-set limit.
  - e. These controls should be tested every time, when putting the system into operation on a new project or a minimum of once yearly.
- F. After placing this unit in operation, the high pressure safety shutoff (blocked-flue) device must be tested. Must be performed by a trained service technician ONLY. The high pressure cutoff switch is located just below and to the left of the burner and is identified with a label.
- a. Remove the chimney rain cap.
  - b. With the burner firing, cover the chimney flue pipe so it is blocked off completely. This should cause the pressure switch contacts to open and shut down the burner.
  - c. Remove the cover from the pipe and replace the rain cap. The burner should not try to re-light since the switch must be manually re-set.
  - d. By pushing the reset button (located under the electrical box cover of the pressure switch), the control will reset and the burner should light again.
  - e. This control should be tested every time, when putting the system into operation on a new project or a minimum of once yearly.
- G. Procedure for cleaning flue gas passageways. This procedure should be performed in the event of blockage in the flue gas passage due to soot or any other obstruction that may occur. Improper burner settings or maintenance could cause soot accumulation in the combustion chamber. The following steps should be taken to clean out the chamber flue gas passageway. Must be performed by a trained service technician ONLY
- a. Shut off and disconnect fuel supply lines and electrical power supply.



## Quest Oil Fired CHH-300 Installation, Operation and Maintenance Instructions

- b. Drain the heat transfer fluid from the system.
  - c. Exterior cabinet side panels and the cabinet door & framing members, at the burner end of the cabinet, should be removed, to facilitate access to the combustion chamber. The control panel should be loosened from its mounting frame. These are all bolt-on components.
  - d. Once access to the chamber has been gained, disconnect the burner electrical supply line and gas supply line and remove the burner. Two bolts will need to be removed that hold the burner to its mounting flange.
  - e. Disconnect the flue gas vent pipe by removing screws. Remove the pipe and rain cap assembly and clean its interior thoroughly.
  - f. The two hoses are connected to 1" fittings that protrude through the front flange plate disk of the combustion chamber. These hoses will need to be disconnected by loosening the hose clamps and pulling the hose off the insert barbs.
  - g. Remove 8 bolts that hold the chamber flange plate disk to the main chamber body.
  - h. The inner section of the combustion chamber can now be pulled straight out of the main chamber body. All flue gas contact surfaces are now exposed and can be easily cleaned with vacuum cleaner, brushes or other cleaning utensils.
  - i. To re-assemble the unit, replace components in reverse order to which they were removed.
  - j. Reconnect gas and power supply to the unit and when re-starting the system perform all safety and service checks as outlined above.
- H. The CHH-300 will produce condensate while operating, at any time that the circulating fluid is cooler than approximately 130°F (54°C). A clear poly-tube is connected to a fitting in the bottom of the chamber at front and is routed to the outside of the cabinet to carry condensate away. This tube should be inspected and cleaned, if necessary, when putting the system into operation on every new project or a minimum of once yearly.
- I. Flame inspection is recommended on a frequent basis (about once per month under normal continuous service) and a flame inspection port is available for this. Must be performed by a trained service technician ONLY.
- a. Normal flame should be bright orange-yellow.
  - b. Although visual inspection is beneficial. We strongly recommend that instruments be used to check combustion quality. This procedure is outlined in (#.1), above.
- J. On a daily basis, the area around this system must continue to be kept clear and free from combustible materials, gasoline and all other flammable vapors and liquids.
- K. At the both ends of the CHH-300 cabinet, louvers are stamped into the access doors to provide intake air for combustion and ventilation. Check on a daily basis to ensure that nothing is allowed to obstruct this free-flow of air.
- L. Check heat transfer fluid level daily. Maintain between  $\frac{1}{4}$  and  $\frac{3}{4}$  level during normal operation. If excessive fluid loss occurs check all hoses and connections for leaks. Top-up only with approved HTF. (See section 4.3 for details).
- M. Verify that all gauges are maintaining within their desired operating ranges with respect to setpoint.
- N. Check fuel tank level daily and order fuel as required.
- O. Make sure that all access doors and panels are kept closed and locked while the system is in use.



# Quest Oil Fired CHH-300 Installation, Operation and Maintenance Instructions

P. Isolate and clean the Y-strainer before each set up, at least once per year or as required due to fluid contamination. To clean the Y-strainer (Fig. 33) close the ball valve, immediately adjacent to the Y-strainer and disconnect the adjacent quick-coupler connection at the alcove manifold (Fig. 28), on the outside of the cabinet. This will isolate the Y-strainer. The cap on the Y-branch can now be removed so the cylindrical screen can also be removed. Clean the screen with compressed air or a small wire brush. Put the screen back in place, replace the cap, re-connect the quick coupler connection and open the valve.

For further service assistance

Call the manufacturer toll free at: 1-866-413-5214

## 6.2 Maintenance Frequency Chart

MAINTAINENCE TASKS	Daily	Start of Every	Start of Heating	As
		Project	Season	Necessary
<b>User Performed Tasks:</b>				
Check pressure & temperature gauges for "Normal Function Levels" during operation	√	√	√	√
Check Aquastat for "Correct Setpoint" during operation	√	√	√	√
Check LED lights for "Correct Function" during operation	√	√	√	√
Check Fuel Gauge and order a delivery if necessary	√	√	√	√
Check HTF Level Gauge and add HTF if necessary	√	√	√	√
If HTF loss is excessive, Check all Hoses & accessories for Leaks and Repair				√
Replace Diesel Fuel Filter			√	√
Clean Y-strainer Screen		√	√	√
Examine all hoses and replace or repair any that are cracked or in any way damaged		√	√	√
Lubricate all quick couplers with light oil			√	√
Thoroughly Clean the system inside and out			√	√
Examine The Flue gas exhaust pipe and Rain cap. Clean as needed		√	√	√
Check condensate drainage tube and clean if necessary		√	√	√
Make certain that no flammable materials are anywhere near the heating unit	√	√	√	√
Make certain that nothing is allowed to obstruct the combustion air intake louvers	√	√	√	√
<b>To be Performed by Trained Service Technician</b>				
Perform a Flue Gas Analysis test (using instruments) to confirm clean combustion		√	√	√
Replace Diesel Burner Nozzle			√	√
Test Ignition Safety Shutoff device on burner		√	√	√
Test Low Water Cut-off Safety switch		√	√	
Test High Temperature Limit switch		√	√	
Test High Pressure Limit (blocked flue) switch		√	√	
Check flue gas passageways for soot or any type of blockage and clean if necessary			√	√



## 7. Troubleshooting

### 7.1 Fault Determination

The CHH-300 is equipped with a group of LED “indicator lights”. The purpose of these lights is to aid in determining where the fault lies if the heating unit should fail to function properly. The following sequence explains the function each light represents and what to look for if that function fails:



### ! IMPORTANT

If all switches have been turned ON and the system has been operating but has now FAILED, the status of these 6 lights will help to isolate the problem.

**All Lights OFF** indicates.

- A. NO power through the main power switch. Check the following:
  - a. Is main power switch (Fig.9) still turned on?
  - b. Are the circuit breakers (Fig. 14) still turned on?
  - c. Verify external power supply (120V) to inlet plug (Fig. 5).

**#1 Unit Power Light is ON** indicates.

- A. Power is present through main switch. The 2 digital temperature gauges should be ON. If not, use a multi-meter to check the following:
  - a. The 2 transformers (Fig. 16) should show 120VAC in and 6VDC out. If power goes in but not out, replace transformer.
  - b. If there is 6VDC at the digital gauge but it does not illuminate, replace the temp. gauge.
- B. There is no power going through the low water cutoff (LWCO) burner control circuit (Fig. 19).
  - a. Check fluid level in reservoir. Should be at least ¼ level. Add if necessary.
  - b. Check, with a multi-meter, for 120V in and out of LWCO switch. If fluid is adequate and there is power in but not out, replace the LWCO switch.

**#2 Glycol Level Light, (plus #1) are ON** indicates.

- A. LWCO switch (Fig. 19) is sensing sufficient glycol in the reservoir and power is going through the switch.
- B. There is no power going through the high temperature auto switch (Fig. 20).
  - a. Check the set points on the high temperature auto switch (Fig. 20) and digital stat (Fig. 8). If the set point of the stat is equal to or higher than the set point of the high temperature auto switch (Fig. 20), the

high temperature auto switch will be functioning like a stat and cycling the burner off and on. Light #3 will be cycling in-step with the burner. The digital stat should always be set (maximum 200°F), a few degrees lower than the high temperature auto switch (about 210°F).

b. With the actual fluid temperature well below the set point of the high temperature auto switch, check, with a multi-meter, for 120V in and out of the high temperature auto switch (Fig. 20). If there is power in but not out, replace the high temperature auto switch.

**#3 High Temp Auto Light, (plus #1 & #2) are ON** indicates.

A. Fluid supply temperature is below the set-point of the high temperature auto switch (Fig. 20) and power is going through the switch.

B. There is no power going through the high temperature Limit switch (Fig. 21).

a. Check the set points on the high temperature Limit switch (Fig. 21), the high temperature auto switch (Fig. 20) and digital stat (Fig. 8). If the set points of both the high temperature auto switch and the stat are equal to or higher than the set point of the high temperature limit switch (Fig. 21), the high temp limit switch will be locked out and the burner off. Light #3 will be off. It will be necessary to push the manual reset button on the front of the high temp limit switch and check the set points of all 3: The high temp auto switch (210°F), the high temp limit switch (220°F) and the digital stat (maximum 200°F).

b. With the high temp limit switch re-set and actual fluid temperature well below the set points of both high temp switches, check, with a multi-meter, for 120V in and out of the high temp limit switch (Fig. 21). If there is power in but not out, replace the high temp limit switch.

**#4 High Temp Limit Light, (plus #1, #2 & #3) are ON** indicates.

A. Fluid supply temperature is below the set-point of the high temp limit switch (Fig. 21) and power is going through the switch.

B. There is no power going through the NC contacts of the high pressure switch (Fig. 22)

a. Check the set-point of the high pressure switch. Start by turning the adjuster screw all the way counter-clockwise. Then turn the screw clockwise 3 full turns. Push the manual reset button on the pressure switch to restore the circuit.

b. Check the air tube connection to the pressure switch and clean if necessary. Push the manual reset button on the pressure switch and the circuit should be restored. If not check for 120 volts going in and out of the control. If power goes in but not out, replace the control.

c. If the circuit is restored briefly but it trips again, blockage may have occurred in the flue gas passage way. Clean the flue gas passages in the combustion chamber (see Maintenance article 6.1 G for instructions) as well as the chimney pipe and rain cap. Repeat step a) above.

**#5 High Pressure Switch Light, (plus #1, #2, #3 & #4) are ON** indicates.

A. Pressure in the combustion chamber and flue pipe has not risen above the high limit cutoff point. Power is going through the NC contacts of the high pressure switch (Fig. 22). Indicates no blockage in any of the flue gas passages.

B. There is no power going through the digital stat switch contacts (Fig. 8).

a. The actual supply fluid temperature may have risen high enough that the operator has cycled off. A call-for-heat will be re-established once the supply fluid temperature has dropped to 5°F below set point.

b. If the actual supply fluid temperature is well below the set point of the stat (at least 10°F lower), check, with a multi-meter, for 120V in and out of the stat. If there is power in but not out, replace the stat and its sensor.



**#6 Stat Light, (plus #1, #2, #3, #4 & #5) are ON** indicates.

- A. The digital stat (Fig. 8) is calling for heat. The burner should be engaged.
- B. If the burner is not functioning, a fault lies within the burner.

## 7.2 Burner Internal Faults

### Diesel/Light Oil Burner

Below is a list of scenarios and possible causes for burner failure.

- A. The burner goes through the prepurge period normally. The flame ignites, but the burner goes to lockout within five seconds.
  - a. The phase/neutral lines are reversed. Correct polarity is critical.
  - b. The wiring to ground is absent or ineffective.
  - c. The electric eye, light-sensing switch is dirty or defective. Try cleaning the eye. If it still fails, replace it.
- B. The burner goes to lockout after the prepurge period because the flame does not ignite.
  - a. No fuel in tank or lines.
  - b. Air has not been fully bled from the fuel lines.
  - c. The fuel filter is dirty. Replace filter.
  - d. Nozzle is plugged. Replace nozzle.
  - e. The spark is irregular or not present. Re-align electrodes.
- C. The burner does not start when the thermostat calls for heat.
  - a. Loose wire connection at terminals L or N.
  - b. Terminals on the control module are bent or loose.
  - c. The motor is defective.
  - d. The capacitor is defective.
  - e. The control box is defective.
- D. For additional information refer to the Riello manual, 40-F10, included in your data package.



## 7.3 Electrical Schematics

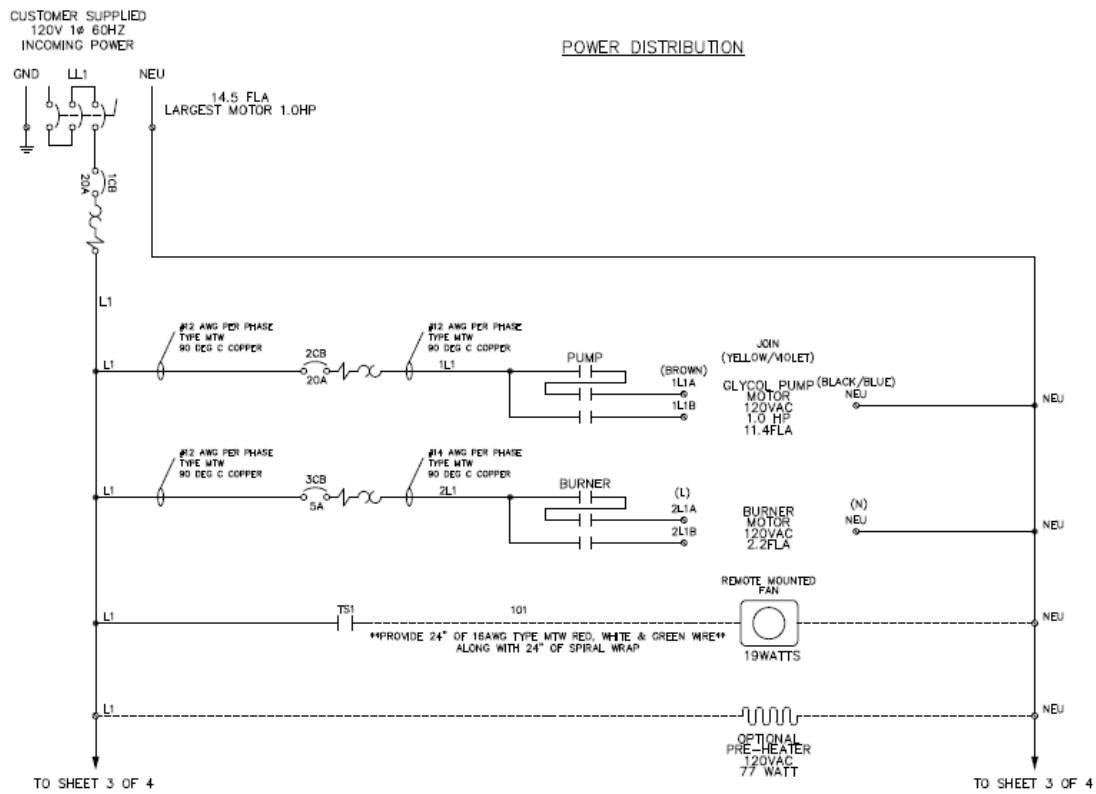



# Quest Oil Fired CHH-300 Installation, Operation and Maintenance Instructions

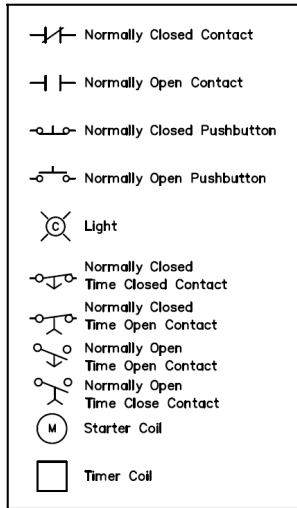

**NOTE:**

- \* CUSTOMER FURNISHED SAFETY DISCONNECT REQUIRED IF MAIN DISCONNECT IS NOT IN SIGHT OF EQUIPMENT
- POWER LUG ON THE COMPONENT
- TERMINAL IN REMOTE JUNCTION/DEVICE BOX
- TERMINAL IN MAIN ENCLOSURE TERMINAL
- - - DASHED LINES INDICATE FIELD WIRING AND/OR CUSTOMER SUPPLIED COMPONENTS

WIRE COLOR CODE	
120 VAC CONTROL	RED
AC NEUTRAL (GROUNDED)	WHITE
DC CONTROL	BLUE
OVDC (GROUNDED)	BLUE W/WHITE TRACER OR WHITE W/BLUE TRACER
FOREIGN VOLTAGE	YELLOW
POWER WIRING	BLACK
GROUND	GREEN OR GREEN W/YELLOW TRACER

FIELD WIRING TO BE COPPER WITH 75°C INSULATION

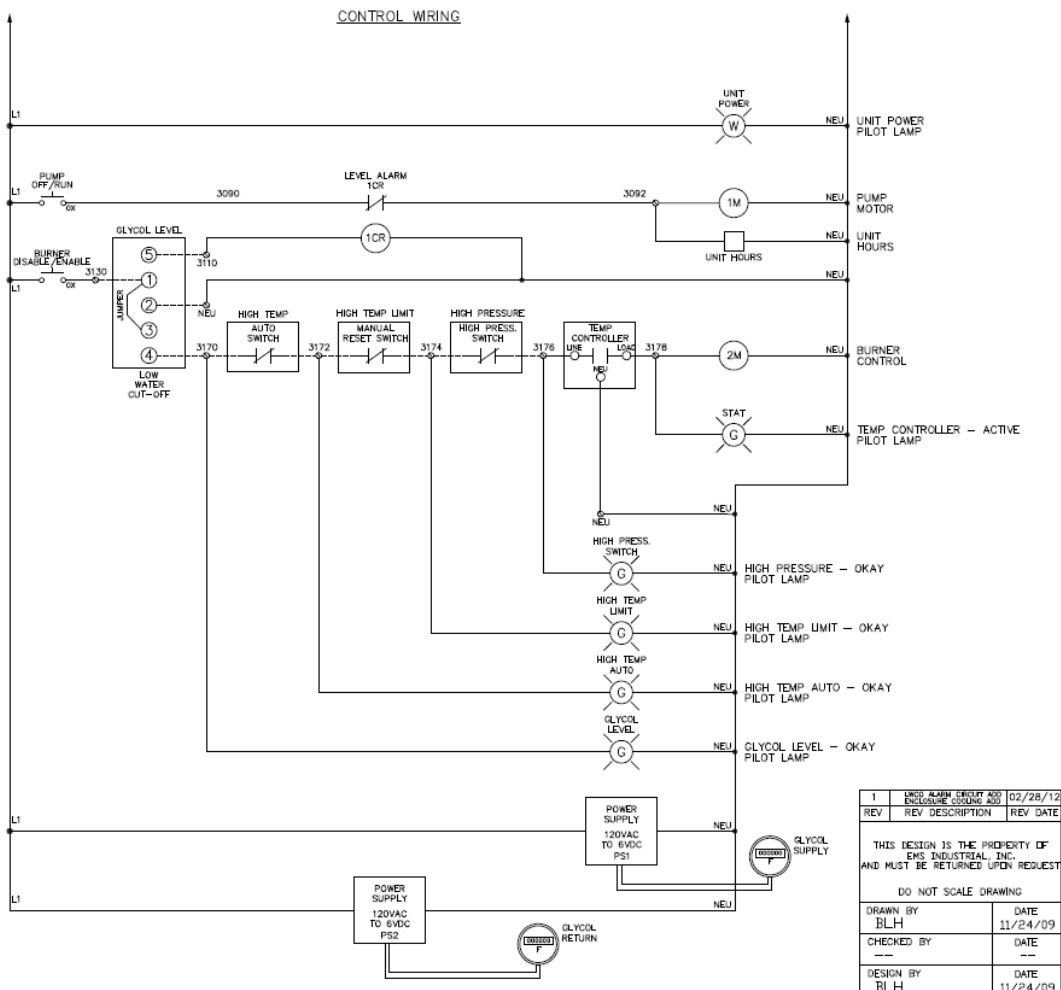

# Quest Oil Fired CHH-300 Installation, Operation and Maintenance Instructions

## Riello Burner Wiring:

### Line Voltage:

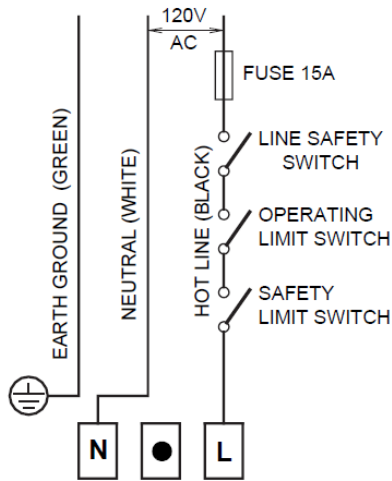

### Sub-base Wiring:

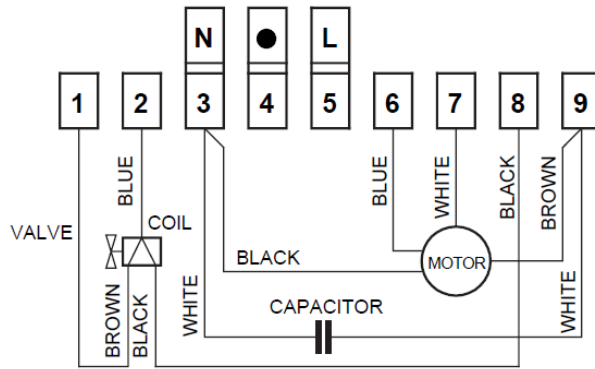

**REMOTE SENSING OF SAFETY LOCKOUT:** The SAFETY SWITCH in the 530SE CONTROL BOX is equipped with a contact allowing remote sensing of burner lockout. The electrical connection is made at terminal 4 (●) on the SUB-BASE. Should lockout occur the 530SE CONTROL BOX will supply a power source of 120Vac to the connection terminal. The maximum allowable current draw on this terminal (4) is 1 Amp.

**WARNING:** If a neutral or ground lead is attached to this terminal, the CONTROL BOX on the burner will be damaged should lockout occur.



## CHH-300 Limited Warranty

### Warrantor:

Therma-Stor LLC  
4201 Lien Rd.  
Madison, WI 53704  
Telephone: 1-866-413-5214

**Who Is Covered:** This warranty extends only to the original end-user of the Quest CHH-300 and may not be assigned or transferred.

**One Year Warranty:** Therma-Stor LLC warrants that, for one (1) year the Quest CHH-300 will operate free from any defects in materials and workmanship, or Therma-Stor LLC will, at its option, repair or replace the defective part(s), free of any charge.

**End-User Responsibilities:** Warranty service must be performed by a Servicer authorized by Therma-Stor LLC. If the end-user is unable to locate or obtain warranty service from an authorized Servicer, the end-user should call Therma-Stor LLC at the above number and ask for the Therma-Stor Service Department., which will then arrange for covered warranty service. Warranty service will be performed during normal working hours.

The end-user must present proof of purchase (lease) upon request, by use of the warranty card or other reasonable and reliable means. The end-user is responsible for normal care. This warranty does not cover any defect, malfunction, etc. resulting from misuse, abuse, lack of normal care, corrosion, freezing, tampering, modification, unauthorized or improper repair or installation, accident, acts of nature or any other cause beyond Therma-Stor LLC' reasonable control.

**Limitations and Exclusions:** If any Quest CHH-300 part is repaired or replaced, the new part shall be warranted for only the remainder of the original warranty period applicable thereto (but all warranty periods will be extended by the period of time, if any, that the Quest CHH-300 Desiccant Dehumidifier is out of service while awaiting covered warranty service).

UPON THE EXPIRATION OF THE WRITTEN WARRANTY APPLICABLE TO THE QUEST CHH-300 OR ANY PART THEREOF, ALL OTHER WARRANTIES IMPLIED BY LAW, INCLUDING MERCHANTABILITY AND FITNESS FOR A PARTICULAR PURPOSE, SHALL ALSO EXPIRE. ALL WARRANTIES MADE BY THERMA-STOR LLC ARE SET FORTH HEREIN, AND NO CLAIM MAY BE MADE AGAINST THERMA-STOR LLC BASED ON ANY ORAL WARRANTY. IN NO EVENT SHALL THERMA-STOR LLC, IN CONNECTION WITH THE SALE, INSTALLATION, USE, REPAIR OR REPLACEMENT OF ANY QUEST CHH-300 OR PART THEREOF BE LIABLE UNDER ANY LEGAL THEORY FOR ANY SPECIAL, INDIRECT OR CONSEQUENTIAL DAMAGES INCLUDING WITHOUT LIMITATION WATER DAMAGE (THE END-USER SHOULD TAKE PRECAUTIONS AGAINST SAME), LOST PROFITS, DELAY, OR LOSS OF USE OR DAMAGE TO ANY REAL OR PERSONAL PROPERTY.

Some states do not allow limitations on how long an implied warranty lasts, and some do not allow the exclusion or limitation of incidental or consequential damages, so one or both of these limitation may not apply to you.

**Legal Rights:** This warranty gives you specific legal rights, and you may also have other rights which vary from state to state.

