

# Quest Gas-Fired CHH-300

## Installation, Operation and Maintenance Instructions

– Read and Save These Instructions –



### **WARNING**

Warning: If the information in these instructions are not followed exactly, a fire or explosion may result causing property damage, personal injury or death.

- Do NOT store or use gasoline or other flammable vapors and liquids in the vicinity of this or any other appliance.

- WHAT TO DO IF YOU SMELL GAS

- Do NOT try to light any appliance.
- Do NOT touch any electrical switch; do not use any phone in your building.
- Immediately call your gas supplier from a neighbor's phone. Follow the gas supplier's instructions.
- If you cannot reach your gas supplier, call the fire department.

- Installation and service must be performed by a qualified installer, service agency or the gas supplier.

“Should overheating occur or the gas supply fail to shut off, do not turn off or disconnect the electrical supply to the pump. Instead, shut off the gas supply at a location external to the appliance.”



**Therma-Stor<sup>®</sup> LLC**

Driven by performance. Powered by design.™

4201 Lien Rd.  
Madison, WI 53704  
www.QuestOnTheJob.com

Phone 608-237-8400  
Toll-Free 1-866-413-5214  
sales@QuestOnTheJob.com

## **⚠ GENERAL HAZARD WARNING**

Failure to comply with the precautions and instructions provided with this unit can result in death, serious bodily injury and property loss or damage from hazards of fire, explosion, burn, asphyxiation, carbon monoxide poisoning, and/or electrical shock.

Only persons who can understand and follow the instructions should use or service this unit.

If you need assistance or unit information such as an instruction manual, label, etc., contact a qualified installer, service agency, gas supplier, or the manufacturer.

## **⚠ WARNING**

### **FIRE, BURN, INHALATION, AND EXPLOSION HAZARD.**

Keep solid combustibles, such as building materials, paper, or cardboard, a safe distance away from the unit as recommended by the instructions. Never use the unit in spaces which do or may contain volatile or airborne combustibles, or products such as gasoline, solvents, paint thinner, dust particles or unknown chemicals.

## **⚠ WARNING**

Do NOT use this appliance if any part has been under water. Immediately call a qualified service technician to inspect the appliance and to replace any part of the control system and any gas control which has been under water.

Should overheating occur, or the gas supply fail to shut off, shut off the manual gas valve to the appliance before shutting off the electrical supply.

## **⚠ WARNING**

Installation must conform to applicable local codes and/or the National Fuel Gas Code, ANSI Z223.1, the Standard for the Storage and Handling of Liquefied Petroleum Gases, ANSI/NFPA 58 and the Natural Gas and Propane Installation Code, CSA B149.1.

Other standards govern the use of fuel gases and heat producing products in specific applications. Your local authority can advise you about these.



## FOR YOUR SAFETY READ BEFORE OPERATING

**WARNING:** If you do not follow these instructions exactly, a fire or explosion may result causing property damage, personal injury or loss of life.

- A. This appliance does not have a pilot. It is equipped with an ignition device which automatically lights the burner. Do not try to light the burner by hand.
- B. **BEFORE OPERATING** smell all around the appliance area for gas. Be sure to smell next to the floor because some gas is heavier than air and will settle on the floor.

### WHAT TO DO IF YOU SMELL GAS

- Do not try to light any appliance.
- Do not touch any electric switch; do not use any phone in your building.
- Immediately call your gas supplier from a neighbor's phone. Follow the gas supplier's instructions.

- If you cannot reach your gas supplier, call the fire department.



- C. Use only your hand to push in or turn the gas control knob. Never use tools. If the knob will not push in or turn by hand, don't try to repair it, call a qualified service technician. Force or attempted repair may result in a fire or explosion.

- D. Do not use this appliance if any part has been under water. Immediately call a qualified service technician to inspect the appliance and to replace any part of the control system and any gas control which has been under water.

## OPERATING INSTRUCTIONS

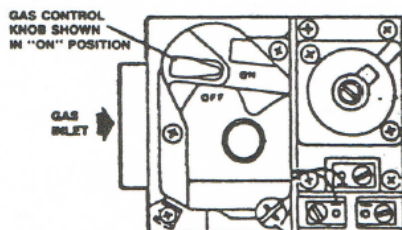
1. **STOP!** Read the safety information above on this label.
2. Turn off all electric power to the appliance.
3. Set the thermostat to lowest setting.
4. This appliance is equipped with an ignition device which automatically lights the burner. Do not try to light the burner by hand.



5. Remove control access panel.
6. Push in gas control knob slightly and turn clockwise  to "OFF."  
NOTE: Knob cannot be turned to "OFF" unless knob is pushed in slightly. Do not force.
7. Wait five (5) minutes to clear out any gas. If you then smell gas, **STOP!** Follow "B" in the safety information above on this label. If you don't smell gas, go to next step.
8. Turn gas control knob counterclockwise  to "ON."
9. Replace control access panel.
10. Set thermostat to desired setting.
11. Turn on all electric power to the appliance.
12. If the appliance will not operate, follow the instructions "To Turn Off Gas To Appliance" and call your service technician or gas supplier.

## TO TURN OFF GAS TO APPLIANCE

1. Turn off all electric power to the appliance if service is to be performed.
2. Set the thermostat to lowest setting.
3. Remove control access panel.
4. Push in gas control knob slightly and turn clockwise  to "OFF." Do not force.
5. Replace control access panel.

## **WARNING**

This appliance is equipped with a Blocked-Flue shutoff device. If any part of the flue-gas passageway in the combustion chamber, exhaust pipe or rain cap should become blocked or adversely restricted, a pressure sensing switch (Fig.22 pg.12) will break the electrical control circuit and not allow the burner to run or the gas valve to open. There is a "Manual Reset" button on this switch that will have to be reset before re-firing can occur. If the burner fails to start after resetting once, call a qualified service technician to clean the flue passageways and/or replace the switch. Cleaning instructions can be found in Section (6.1 G) of the Maintenance section of this manual.

# Quest Gas Fired CHH-300 Installation, Operation and Maintenance Instructions

Table of Contents	Page
1. System Description & Features .....	5
1.1 Description .....	5
1.2 Features .....	6
2. Safety .....	6
2.1 General Safety Guidelines.....	6
2.2 Safety Devices and Clearances .....	7
2.3 Heat Transfer Fluid .....	7
3. Specifications.....	7
3.1 Construction Specifications.....	7
3.2 Dimensions & Capacities Chart.....	8
3.3 Propane Burner & Fuel Specifications .....	8
3.4 Natural Gas Burner & Fuel Specifications.....	9
3.5 Circulation Pump.....	9
3.6 Electrical Requirements for Complete System	10
3.7 Gauges & Indicator Lights .....	11
3.8 Controls & Electrical .....	11
3.9 Controls, Switches, & Gauges Identification ..	13
4. Setup.....	14
4.1 Positioning Equipment on the job.....	14
4.2 Hose & Accessory Connections.....	14
4.3 Charging the Fluid System.....	16
4.4 Propane Gas Burner Installation & Setup.....	17
4.5 Natural Gas Burner Installation & Setup .....	18
5. Operation.....	18
5.1 Startup .....	18
5.2 Shutdown.....	19
6. Maintenance .....	19
6.1 Service Instructions and Checks .....	19
6.2 Maintenance Frequency Chart.....	23
7. Troubleshooting .....	23
7.1 Fault Determination .....	23
7.2 Burner Internal Faults .....	25
7.3 Electrical Schematics.....	26
Warranty .....	29

Serial No. \_\_\_\_\_

Purchase Date \_\_\_\_\_

Dealer's Name \_\_\_\_\_



## 1. System Description & Features



1: CHH-300, Pump End



2: CHH-300, Burner End

### 1.1 Description

- The CHH is a fuel burning appliance, designed to heat fluid “on demand” and provide pumped circulation of the fluid for use in various portable hydronic applications.
- The CHH provides a central source of hot “heat transfer fluid” (HTF) for use with dependent heat exchangers such as:
  - Fan coils for heating and drying of structures.
  - Multi-circuit line heat exchange hose or tubing for ground thawing, concrete curing, snow melting and slab heating.
  - Custom hydronic heat exchange accessories and applications.
- The CHH gas-fired units can be equipped with either of 2 burners, each dedicated to burn one of the following:
  - Natural Gas.
  - Propane Gas.
- Pumping and combustion control are achieved with electrical components. The CHH-300 requires a 120 volt, 20 amp, 3-wire grounding circuit.
- The CHH is designed for consistently-efficient outdoor operation.

## 1.2 Features

- All exposed components are made of non-corrosive materials such as stainless steel, brass or aluminum.
- The “HTF” circuit includes an open, atmospherically-vented expansion tank, which effectively eliminates the system from pressure vessel classification.
- The control system includes a sequence of status indicator lights which provide a quick function check and trouble-shooting aid for the operator.
- The combustion chamber/heat exchanger is completely fabricated from stainless steel and is not susceptible to corrosion. Temperature turn-down for prolonged periods of operation (such as for concrete curing) will not harm the chamber.
- For security and environmental protection, all valves, controls, burner, pump, filters and “HTF” tank filler are either secured behind lockable access doors or are self-lockable.
- Temperature gauges, pressure gauge, system status indicator lights and “HTF” tank level gauge are visible to the operator even when the system is securely locked down.
- Burners approved for use with the system, come with a permanently installed pressure gauge to simplify adjustment of gas pressure when setting up the burner.
- Door handles and hose connection couplers for the external HTF circuit are recessed so as not to create “snag-points” when moving, shipping or delivering the unit.

## 2. Safety

### CAUTION

#### 2.1 General Safety Guidelines:

##### **CAUTION! This is a fuel burning appliance.**

- Some surfaces will become **extremely HOT!**
- When using propane or natural gas, the chance of **FIRE** or **EXPLOSION** always exists! Always follow safe-operating practices and comply with local fire and gas codes.
- Before attempting to setup or operate this equipment, it is imperative that the Operator reads and understands all the information in this manual.
- Untrained people should not attempt to operate this equipment until they receive proper instruction.
- Maintain instructional and safety labels. Replace damaged labels.
- Observe all posted warnings and cautions.
- Always wear suitable protective clothing and accessories such as safety glasses, leather gloves, certified work boots and hard hat when working with or operating this equipment.
- Keep children, pets and all untrained by-standers clear from the heater and accessories.



## 2.2 Safety Devices and Clearances

- All safety devices must be in place and functioning properly when the equipment is in operation.
- All hydronic heater panels and doors must be kept closed when the system is operating.
- The flue-gas exhaust pipe and rain-cap requires a minimum of 6" (152 mm) clearance, from any type of combustible material.
- Clearance from any obstructive objects must be maintained to a minimum of 36" (914 mm) from both ends of the hydronic heater.
- Do not allow anything to obstruct the "Combustion Air Intake".

## 2.3 Heat Transfer Fluid

**Precautions and measures to follow when working with "heat transfer fluid" (Inhibited aqueous propylene glycol).**

- Ventilation - Good general ventilation should be sufficient for most conditions.
- Respiratory protection - No respiratory protection should be needed.
- Skin protection - For brief contact, no precautions other than clean body-covering clothing should be needed.
- Use impervious gloves when prolonged or frequently repeated contact should occur.
- Eye protection - Use safety glasses.

### **First aid measures.**

- Eyes - Flush eyes with plenty of water.
- Skin - Wash off in flowing water or shower.
- Ingestion - Induce vomiting if large amounts are ingested. Consult medical personnel.
- Inhalation - Remove to fresh air if effects occur. Consult a physician.
- Note to physician - No specific antidote. Supportive care. Treatment based on judgement of the physician in response to reactions of the patient.

## 3 Specifications

### 3.1 Construction Specifications

- The "CHH" includes an aluminum "enviro-containment" base, with fork-lift pockets.
- The exterior enclosure panels are made of stainless steel.
- The framework for the enclosure and the base are built of structural aluminum. A top center hoisting hook is included.



# Quest Gas Fired CHH-300 Installation, Operation and Maintenance Instructions

- Primary access for operation and service is provided for through hinged, lockable doors at the two ends of the enclosure.
- Both side panels and both roof panels are fastener-attached for potential removal.
- Then combustion chamber/heat exchange section is fabricated from stainless steel.
- Access for cleaning the chamber is from the burner end with minimal disassembly required. The procedure consists of removing the burner and inside chamber section.
- Temperature turn-down and condensing within the chamber can not harm the chamber.
- The exhaust flue for the burner exits through the roof of the enclosure. The exposed roof flashing is made from aluminum. The rain cap and flue pipe are made of stainless steel.

## 3.2 Dimensions and Capacities

Length of Cabinet	inches (millimeters)	72 (1829)
Width of Cabinet	inches (millimeters)	22 (559)
Height of Cabinet	inches (millimeters)	48 (1219)
Height to Top of Rain Cap	inches (millimeters)	58 (1473)
Heat Transfer Fluid Capacity	US gallons (liters)	20 (76)
Weight: with heat transfer fluid	pounds (kilograms)	600 (272)

## 3.3 Propane Gas Burner and Fuel Specifications (Fig. 3)

- The “Gas Burner” is a power, forced-draft, type with direct spark ignition, manufactured by Riello Burners.
- A CSA/UL version gas train is factory installed in units equipped for either propane or natural gas. The gas train works with either burner.
- Two gauges are mounted to pressure-tap ports on the gas train for use in setting the burner and monitoring performance(Fig. 24) .

Riello Burner Model	Propane	40-G400-LP
Operational Mode		single stage
Electrical Characteristics	V / A / Hz / Ph	120 / 2.2 / 60 / 1
Orifice: factory equipped	#	1.5
Diaphragm: factory equipped	#	C14
Gas Supply Pressure: Minimum	“WC (KPa)	8 (1.99)
Gas Supply Pressure: Maximum	“WC (KPa)	13 (3.24)
Gas Manifold Pressure ( $\Delta$ P): factory set	“WC (KPa)	5.0 (1.25)
Heat Setting: factory set	#	1
Air Gate Setting: factory set	#	3.0
Heat Input	B/tu/H (Watts)	250,000 (73,250)
Heat Output: @ 80% net efficiency	B/tu/H (Watts)	200,000 (58,600)





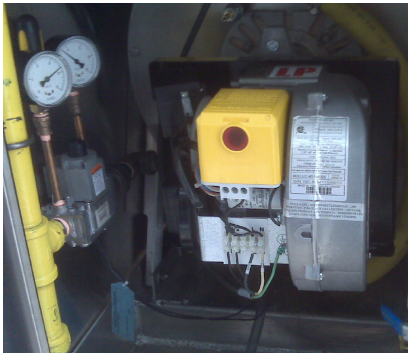

**3: Gas Burner, LP or Natural Gas Train**

### 3.4 Natural Gas Burner and Fuel Specifications (Fig. 3)

- The “gas burner” is a power, forced-draft, type with direct spark ignition, manufactured by Riello Burners.
- A CSA/UL version gas train is factory installed in units equipped for either natural gas or propane. The gas train works with either burner.
- Two gauges are mounted to pressure-tap ports on the gas train for use in setting the burner and monitoring performance (Fig. 24).

Riello Burner Model	Natural Gas	40-G400-NG
Operational Mode		single stage
Electrical Characteristics	V / A / Hz / Ph	120 / 2.2 / 60 / 1
Orifice: factory equipped	#	2.2
Diaphragm: factory equipped	#	C4
Gas Supply Pressure: Minimum	“WC (KPa)	7 (1.74)
Gas Supply Pressure: Maximum	“WC (KPa)	10.5 (2.61)
Gas Manifold Pressure ( $\Delta$ P): factory set	“WC (pascals)	3.8 (946)
Heat Setting: factory set	#	1
Air Gate Setting: factory set	#	3.5
Heat Input	B/tu/H (Watts)	300,000 (87.9)
Heat Output: @ 80% net efficiency	B/tu/H (Watts)	240,000 (70,320)

### 3.5 Circulation Pump (Fig. 4)

- The HTF circulation pump is a stainless steel, direct drive centrifugal type.
- The pump is located inside the enclosure at the opposite end to the burner and can be accessed through a hinged lockable door (Fig. 1).
- A panel-mounted pressure gauge is connected to the output side of the HTF pump by means of a 1/8” ID hydraulic hose and fittings (Fig. 23).

# Quest Gas Fired CHH-300 Installation, Operation and Maintenance Instructions

Goulds Pump Model		1ST1E4C4
Impeller Diameter	inches (millimeters)	5.1875 (132)
Motor Horsepower	HP (Watts)	1.0 (746)
Voltages pump can run on	Volts	120/240
Full Load Amp Rating - Franklin motor	Amps	10.4/5.2
- Emerson motor	Amps	12.3/6.2
System Design Flow Rate	USGPM (liters/sec)	30 (1.89)
System Design Operating Pressure	PSI (kilopascals)	35 (241)



**4: Fluid circulation Pump**

## 3.6 Electrical Requirements for Complete System

Supply Voltage	Volts	120
Circuit Amperage	Amps	20
Hertz	HZ	60
Phase	PH	single-
Control Circuit Voltage	Volts	120
Power Inlet - NEMA Twistlock		L5-20P



**5: Power Inlet Plug**



## 3.7 Gauges and Indicator Lights

- A cluster of gauges and status-indicator lights are located inside the UL approved control panel. This panel is located behind the burner access door near the top (Fig. 2). These gauges and lights are visible from the exterior through plexi-glass windows in the access door and the control panel door.
- A digital gauge (Fig. 12) monitors each of the following:
  - HTF supply temperature.
  - HTF return temperature.
- A digital hours meter (Fig. 12) logs system run-time.
- A series of 6, LED indicator lights (Fig. 13) illuminate in sequence as each of the following scenarios is proven:
  - #1 - 115 volt control power is present - clear lens.
  - #2 - HTF level is adequate in reservoir - green lens.
  - #3 - High temp auto switch has not interrupted the circuit - green lens.
  - #4 - High temp limit control has not interrupted the circuit - green lens.
  - #5 - High pressure switch has not interrupted the circuit - green lens.
  - #6 - Aquastat is calling for heat - green lens.



6: Control Panel, Outer



7: Control Panel, Inner

## 3.8 Controls and Electrical

- The UL approved electrical box, located inside the enclosure, above the burner, houses specific electrical components, besides the lights and gauges, and serves as a junction box for cords going to and from remote electrical components (Fig. 6 & Fig. 7).
- The following components are part of and are located in or on the UL approved box:
  - Main power disconnect (Fig. 9).
  - Pump ON/OFF switch (Fig. 10).
  - Burner circuit ON/OFF switch (Fig. 11).

## Quest Gas Fired CHH-300 Installation, Operation and Maintenance Instructions

- Main system breaker (Fig. 14).
- Pump circuit breaker (Fig. 14).
- Burner circuit breaker (Fig. 14).
- Power disconnect switch (Fig. 15).
- Temperature gauge transformers 6VDC (Fig. 16).
- LED lights - 120 volt (Fig. 13).
- Hours meter - 120 volt (Fig. 12).
- Terminal blocks (Fig. 18).
- Contactors (Fig. 17).
- Electronic operating thermostat (Fig. 8).
- The following items are remotely connected to cords that exit from the control panel: (see chart below for details of these components)
  - Main power male inlet-plug (twist lock) (Fig. 5).
  - Low water cut-off switch (mounted on HTF reservoir) (Fig. 19).
  - High Temp Auto switch (mounted in HTF plumbing circuit) (Fig. 20).
  - High Temp Limit switch (mounted in HTF plumbing circuit) (Fig. 21).
  - High Pressure Limit switch (Fig. 22).
  - HTF circulating pump (Fig. 4). (see pump chart above for details)
  - Burner (Fig. 3). (see burner chart above for details)



## 3.9 Controls, Switches & Gauges Identification

- Mounted on Control Panel



8: Operator, Digital



9: Main Power Switch Knob



10: Pump Switch



11: Burner Switch

- Mounted Behind Control Panel



12: Temperature Gauges & Hour Meter

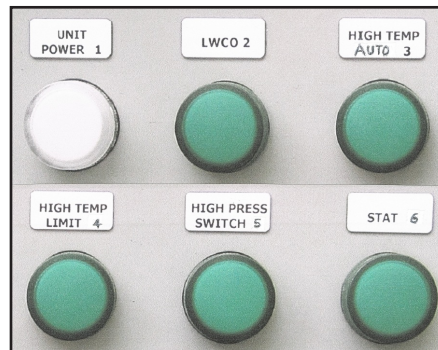

13: LED Indicator Lights

- Mounted Remotely



14: Circuit Breakers



15: Main Power Switch Body



16: Transformers for Digital Temp. Gauges



17: Contactors



18: Terminal Blocks

- Pump and Gas Pressure Gauges



19: Low Water Cutoff



20: High Temp Auto Switch



21: High Temp Limit Switch



22: High Pressure Switch



23: Pump Pressure Gauge (PSI)



24: Gas Pressure Gauges ("WC)

## 4. Setup

### 4.1 Positioning Equipment on the Job

Before choosing the location to place the central hydronic heater on a job site, several factors should be considered.

- If possible, the CHH should be placed at a central position that will minimize and equalize the lengths of hoses. This helps to ensure maximized and equalized HTF flow.
- Convenient access to a suitable electrical connection, if site power is to be used. 120V, 1PH, 60Hz, 20A, 3-wire grounding is required.
- Convenient access to bulk truck re-fueling in the case of propane systems.
- Do not locate in the path of job site traffic.
- Avoid locations that will expose the CHH to intense dust or other sources of air contamination. Clean flowing air is essential to maintain clean combustion.
- Observe all requirements listed in the "Instructions for Installation" document provided with this unit.

### 4.2 Hose and Accessory Connections

In order to make use of the heated fluid, it is necessary to lay out a circuit of hoses to; distribute the hot fluid, transfer it's heat to another medium and return the cooled fluid to the CHH for re-heating (Fig. 25).

# Quest Gas Fired CHH-300 Installation, Operation and Maintenance Instructions

- Primary 1" hoses are used from the CHH quick-connect couplings (Fig. 26) to feed a manifold for either multiple fancoils in air heating situations (Fig. 28) or multiple 5/8" hose circuits for ground thawing, concrete curing, slab heating or snow melting (Fig. 29).
- Use only "approved hose" as supplied by ThermaStor. Otherwise, compatibility issues may arise.
- Hoses are pre-charged with the recommended mixture of water and propylene glycol and are equipped with hydraulic-style quick couplers. Every hose has a male connector on one end and a female connector on the other end; therefore any hose can be used for either the supply side or the return side of the hose circuit.
- Route hoses to achieve minimum chance of damage from traffic of any kind and at the same time minimize the overall circuit length.
- Provide protection from "Kinking" of hoses that would restrict flow.
- When connecting quick couplers, ensure that the connections are "Fully Engaged" and snapped into place or flow will not take place through the coupler connection.
- For long term, building heating projects it is advised to insulate all hose sections located outdoors, between the CHH-300 and the exterior building wall. Special "Insulating Wraps" are available for this purpose.

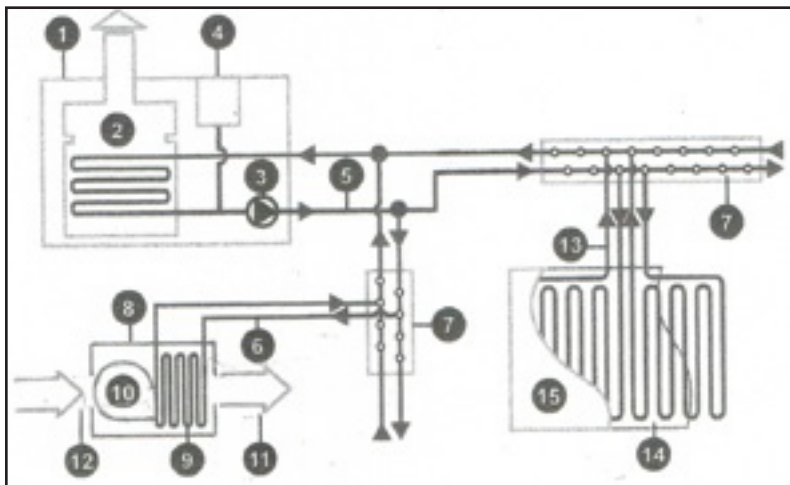

25: Layout for Fluid Distribution

- |                                      |  |
|--------------------------------------|--|
| 1. Central Hydronic Heating Unit     | 9. Heat Transfer Coil                  |
| 2. Burner & Heat Exchanger           | 10. Air Moving Fan                     |
| 3. Circulating Pump                  | 11. Heated Supply Air                  |
| 4. Reservoir for Expansion & Filling | 12. Intake Air                         |
| 5. Primary Fluid Hoses, 1"           | 13. Hose Grid Line Heat Exchanger 5/8" |
| 6. Secondary Fluid Hoses, 3/4" or 1" | 14. Vapor Barrier                      |
| 7. Manifold for Multiple Connections | 15. Insulated Tarps                    |
| 8. Fancoil Heat Exchanger            |  |



# Quest Gas Fired CHH-300 Installation, Operation and Maintenance Instructions



26: Hoses Connected to CHH Unit



27: Fancoil Connected to CHH Unit

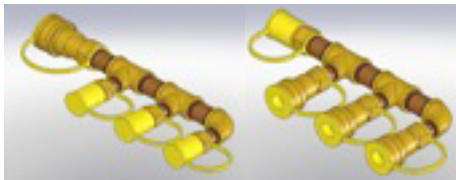

28: Manifolds for Fancoils - Supply & Return

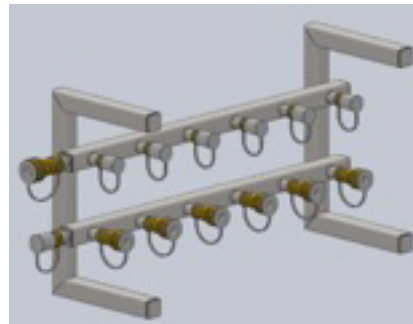

29: Manifold for Thaw & Cure

## 4.3 Charging the Fluid System



30: HTF Level Gauge & Vented Filler Cap



31: HTF Circuit Valves, Y-strainer & High Temp. Limit

- The CHH-300, all hose and all accessories are shipped pre-charged with the “approved blend” of heat transfer fluid (HTF). The required fluid is a 50% blend of Inhibited propylene glycol and de-mineralized neutral PH (#7) water. (Freeze protection to -29°F). The HTF provided with a new system and accessories is marketed as DowFrost. Use of any other product that cannot be proven to be equal in all respects will void warranty of the system.



# Quest Gas Fired CHH-300 Installation, Operation and Maintenance Instructions

- Check the HTF level gauge (Fig. 30). The reservoir should be  $\frac{1}{4}$  to  $\frac{1}{2}$  full when the system is cold. Add approved fluid, if necessary, at the vented filler cap (Fig. 30).
- Connect all primary hoses from the CHH-300 to the distribution manifold.
- Place all fancoils in the desired locations and route all the hoses to them OR lay out all hose grid circuits for ground thaw or concrete curing.
- Connect hoses from the manifold to ONE fancoil or ONE thaw/cure loop ONLY.
- Open 2 HTF circuit valves (Fig. 31). Turn ON the circulating pump switch (Fig. 10) and let the fluid circulate until all the air is eliminated from the first branch circuit. Air has been purged when steady pressure of 30 to 35 PSI is observed at the glycol pressure gauge (Fig. 22).
- Connect each fancoil or thaw/cure loop, in turn, one at a time, in the same manner as above. When all are connected and the pressure gauge maintains steady pressure, the system is charged and ready for use.
- Check the HTF level again and top up if necessary ( $\frac{1}{4}$  to  $\frac{1}{2}$  full).

## 4.4 Propane Burner Installation and Setup (Fig. 3)

- Refer to the Riello Burner 40-G400 manual (which is included with this package) for detailed information and instruction.
- Specific propane gas burner settings for the CHH-300 are as follows.

Riello Burner Model		40-G400
Orifice:	#	1.5
Diaphragm:	#	C14
Gas Supply Pressure: Minimum	"WC (KPa)	8 (1.99)
Gas Supply Pressure: Maximum	"WC (KPa)	13 (3.24)
Gas Manifold Pressure ( $\Delta$ P): factory set	"WC (KPa)	5.0 (1.25)
Head Setting: factory set	#	1
Air Gate Setting: factory set	#	3.0
Heat Input	B/tu/H (Watts)	250,000 (73,250)
Heat Output: @ 80% net efficiency	B/tu/H (Watts)	200,000 (58,600)



## 4.5 Natural Gas Burner Installation and Setup (Fig. 3)

- Refer to the Riello Burner 40-G400 Manual (which is included with this package) for detailed information and instruction.
- Specific natural gas burner settings for the CHH-300 are as follows.

Riello Burner Model		40-G400
Orifice:	#	2.2
Diaphragm:	#	C4
Gas Supply Pressure: Minimum	"WC (KPa)	7 (1.74)
Gas Supply Pressure: Maximum	"WC (KPa)	10.5 (2.61)
Gas Manifold Pressure ( $\Delta$ P): factory set	"WC (KPa)	3.8 (0.95)
Head Setting: factory set	#	1
Air Gate Setting: factory set	#	3.5
Heat Input	B/tu/H (Watts)	300,000 (87,900)
Heat Output: @ 80% net efficiency	B/tu/H (Watts)	240,000 (70,320)

## 5. Operation

### 5.1 Startup

- Make sure the CHH-300 is connected to a correct, stable power source (120V, 20A, 60Hz, 3-wire Grounding) and proper gauge chords are used (12 gauge minimum).
- Verify adequate and correct fuel supply for the burner as it is equipped on the system (propane or natural gas). Open all valves in the respective fuel-supply lines.
- Make sure at least one circuit of HTF hose is connected to the CHH-300 to provide adequate circulation (see hose and accessory connections section 4.2).
- At the control panel (Fig. 6), remove 2 thumb screws to open and expose the inner panel (Fig. 7), turn ON the three breakers located behind the light panel (Fig. 14). Close and refasten the panel.
- Turn ON the main power switch (Fig. 9). The white unit power light (Fig. 13) will come on, as well as the two digital temperature gauges and hour meter (Fig. 12).
- Turn ON the pump switch (Fig. 10) and check the pump pressure gauge (Fig. 22). Steady pressure around (30 to 35 PSI), indicates that no air remains in the fluid circuit.
- Once a stable pump pressure is achieved, turn ON the burner switch (Fig. 11). The following sequence should now occur: Observe the LED light cluster (Fig. 13).
  - The glycol level light will turn on (indicating that there is a sufficient amount of HTF in the system).
  - The high temp auto light will turn on (This indicates that the high temp auto safety switch has not broken the circuit).
  - The high temp limit light will turn on. (This indicates that the high temp limit safety switch has not broken the circuit).
  - The high pressure limit switch light will turn on. (This indicates that the blocked flue high pressure safety switch has not broken the circuit).
  - A few seconds later, the stat light will come on and the burner fan will purge the combustion chamber for a few seconds.



-The burner should light following the pre-purge. If air is still present in the gas lines, the burner may not light and will lock out. It might be necessary to push the red reset button on the burner module 2 or 3 times until gas reaches the burner head and ignition takes place.

- Make sure the stat (Fig. 8) is set at the desired temperature. DO NOT Operate at temperatures above 200°F, or damage to inline controls and certain accessory components can result. To adjust setpoint on this control just use the up and down key. There is no need to go into the menu of the control to perform this function. The control simultaneously displays setpoint temperature and actual supply fluid temperature.
- Once the setpoint temperature has been reached, the burner will cycle off and on as needed.

## 5.2 Shutdown

- Turn OFF the burner switch (Fig. 11). The burner will no longer recycle but the circulation pump will continue to run.
- It is recommended that the fluid be allowed to continue circulating until it has cooled down to 100°F or lower.
- Turn OFF the pump switch (Fig. 10). If any fancoils and hoses have been placed at a higher elevation than the CHH-300, the primary hoses should be immediately disconnected from the CHH-300 (Fig. 26). This will prevent fluid from draining back and overflowing at the HTF reservoir vent (Fig. 30).
- Turn OFF the main power switch (Fig. 9).
- Turn OFF manual gas supply valves.
- If the system is to be de-commissioned, it is now safe to disconnect the power supply, the natural gas or propane supply (if applicable) and all HTF circulation hoses, manifolds and accessories.

## 6. Maintenance

### 6.1 Service Instructions and Checks

#### **CAUTION**

**“CAUTION: Label all wires prior to disconnection when servicing controls. Wiring errors can cause improper and dangerous operation. Verify proper operation after servicing.”**

A. To achieve and ensure clean combustion from the burner, a “Flue-Gas Analyzer” must be used to verify clean combustion. Perform the following checks while the burner is firing. Must be performed by a trained service technician ONLY. Refer to the Riello burner Manual for burner adjustment instructions. This check should be performed, every time, when putting the system into operation on a new project and a minimum of once yearly.

- a. Ensure that the gas manifold pressure is at 3.5”WC for propane fired units or 3.8”WC for natural gas fired units. Adjust if necessary.
- b. Regulation of combustion air flow is made by adjustment of the manual air adjustment plate. Initial suggested setting is (3.5) for natural gas and (3.0) for propane gas.
- c. Final position of the air adjustment plate must be set based on instrument readings of not greater than 12.0% CO<sub>2</sub> for propane-fired systems and 10% CO<sub>2</sub> for natural gas systems. Final readings must be taken with all service-access doors closed.



## Quest Gas Fired CHH-300 Installation, Operation and Maintenance Instructions

- B. After placing this unit in operation, the ignition system safety shutoff device must be tested. Must be performed by a trained service technician ONLY. This check should be performed, every time, when putting the system into operation on a new project or a minimum of once yearly.
- Shut OFF the "Burner Circuit" power switch.
  - Disconnect the electrical wire which connects the "Ionization Probe" to the burner's control box. The wire has a clip-together connector for convenience.
  - Turn the power switch back ON and initiate burner lighting procedure. After the short pre-purge cycle, the burner should light but go out in 5 seconds and lock out. If the burner does not lock out with the ionization probe's lead wire disconnected, consult the operator's manual for troubleshooting procedures.
  - To put the unit back in standard operating mode, turn OFF the burner circuit power switch, re-connect the electrical wire which connects the "Ionization Probe" to the burner's control box and turn ON the "Burner Circuit" power switch.
- C. Examine the flue gas exhaust pipe and rain cap to be sure they are solidly attached and free from any type of obstruction. Clean if necessary.
- This check should be performed, every time, when putting the system into operation on a new project or a minimum of once yearly.
- D. After placing this unit in operation, the low water safety shutoff device must be tested. Must be performed by a trained service technician ONLY. The low water cutoff switch is located in plain view at the same end of the CHH-300 as the circulating pump and is identified with a label.
- Push the test switch on the outside of the control. This will simulate a "Low Water" condition and open the burner circuit to prevent burner initiation.
  - By pushing the reset switch, the control will restore function to the burner circuit as long as there is fluid touching the probe. The electronic probe is a "self cleaning" type and should not require service.
  - This control should be tested every time, when putting the system into operation on a new project or a minimum of once yearly.
- E. After placing this unit in operation, the high temperature limit safety shutoff device must be tested. Must be performed by a trained service technician ONLY. Two high temperature limit switches are located in plain view at the same end of the CHH-300 as the circulating pump and are identified with labels. One of these switches re-sets itself automatically and is set at a slightly lower temperature (about 5°F) than the other which must be manually re-set after its set point has been reached.
- With the burner firing, set the main digital operating stat to a temperature value that is at least 5°F higher than the set point of the manual re-set high temperature limit switch.
  - When the fluid temperature reaches the set point of the automatic re-set limit switch, it should shut down the burner. As the fluid cools down 2 or 3 degrees, the burner should re-fire. This automatic re-set limit switch should function like a second thermostat and will take over as operator of the burner.
  - If you now adjust the set point of the automatic re-set limit switch to a level a few degrees higher than the set point of the manual re-set limit switch, the burner should continue to fire until the set point of the manual re-set high limit is reached. At this point the burner should be shut down and this time should not come back on as the fluid cools back down.
  - The manual re-set high limit will need to be manually re-set, by pushing the red re-set button. Adjust the operator back down to a normal operating lower setting and re-adjust the automatic high limit back down to its regular set point at about 5°F lower than the manual re-set limit.



## Quest Gas Fired CHH-300 Installation, Operation and Maintenance Instructions

- e. These controls should be tested every time, when putting the system into operation on a new project or a minimum of once yearly.
- F. After placing this unit in operation, the high pressure safety shutoff (blocked-flue) device must be tested. Must be performed by a trained service technician ONLY. The high pressure cutoff switch is located just below and to the left of the burner and is identified with a label.
  - a. Remove the chimney rain cap.
  - b. With the burner firing, cover the chimney flue pipe so it is blocked off completely. This should cause the pressure switch contacts to open and shut down the burner.
  - c. Remove the cover from the pipe and replace the rain cap. The burner should not try to re-light since the switch must be manually re-set.
  - d. By pushing the reset button (located under the electrical box cover of the pressure switch), the control will reset and the burner should light again.
  - e. This control should be tested every time, when putting the system into operation on a new project or a minimum of once yearly.
- G. Procedure for cleaning flue gas passageways. This procedure should be performed in the event of blockage in the flue gas passage due to soot or any other obstruction that may occur. Improper burner settings or maintenance could cause soot accumulation in the combustion chamber. The following steps should be taken to clean out the chamber flue gas passageway. Must be performed by a trained service technician ONLY.
  - a. Shut off and disconnect external gas supply and electrical power supply.
  - b. Drain the heat transfer fluid from the system.
  - c. Exterior cabinet side panels and the cabinet door & framing members, at the burner end of the cabinet, should be removed, to facilitate access to the combustion chamber. The control panel should be loosened from its mounting frame. These are all bolt-on components.
  - d. Once access to the chamber has been gained, disconnect the burner electrical supply line and gas supply line and remove the burner. Two bolts will need to be removed that hold the burner to its mounting flange.
  - e. Disconnect the flue gas vent pipe by removing screws and clamping bands. Remove the pipe and rain cap assembly and clean its interior thoroughly.
  - f. Two hoses are connected to 1" fittings that protrude through the front flange plate disk of the combustion chamber. These hoses will need to be disconnected by loosening the hose clamps and pulling the hose off the insert barbs.
  - g. Remove 8 bolts that hold the chamber flange plate disk to the main chamber body.
  - h. The inner section of the combustion chamber can now be pulled straight out of the main chamber body. All flue gas contact surfaces are now exposed and can be easily cleaned with vacuum cleaner, brushes or other cleaning utensils.
  - i. To re-assemble the unit, replace components in reverse order to which they were removed.
  - j. Reconnect gas and power supply to the unit and when re-starting the system perform all safety and service checks as outlined above.



## Quest Gas Fired CHH-300 Installation, Operation and Maintenance Instructions

H. The CHH-300 will produce condensate while operating, at any time that the circulating fluid is cooler than approximately 130°F (54°C). A clear poly-tube is connected to a fitting in the bottom of the chamber at front and is routed to the outside of the cabinet to carry condensate away. This tube should be inspected and cleaned, if necessary, when putting the system into operation on every new project or a minimum of once yearly.

I. Flame inspection is recommended on a frequent basis (about once per month under normal continuous service) and a flame inspection port is available for this. It is located just above the burner on the front flange plate disk of the combustion chamber. A 3/8" NPT plug must be removed to see into the inner chamber while the burner is fired. Be sure that the plug is replaced when this check is complete. Must be performed by a trained service technician ONLY.

a. Normal flame for natural gas or propane should be blue with slight orange tips at the cone of the flame.

b. Although visual inspection is beneficial. We strongly recommend that instruments be used to check combustion quality. This procedure is outlined in (#.1), above.

J. On a daily basis, the area around this system must continue to be kept clear and free from combustible materials, gasoline and all other flammable vapors and liquids.

K. At the circulation pump end of the CHH-300 cabinet, Louvers are stamped into the access door to provide intake air for combustion and ventilation. Check on a daily basis to ensure that nothing is allowed to obstruct this free-flow of air.

L. Check heat transfer fluid level daily. Maintain between 1/4 and 3/4 level during normal operation. If excessive fluid loss occurs check all hoses and connections for leaks. Top-up only with approved HTE.

M. Verify that all gauges are maintaining within their desired operating ranges with respect to setpoint.

N. For propane systems ONLY. Check fuel tank level daily and order fuel as required.

O. Make sure that all access doors and panels are kept closed and locked while the system is in use.

P. Isolate and clean the Y-strainer before each set up, at least once per year or as required due to fluid contamination. To clean the Y-strainer (Fig. 31) close the ball valve, immediately adjacent to the Y-strainer and disconnect the adjacent quick-coupler connection at the alcove manifold (Fig. 26), on the outside of the cabinet. This will isolate the Y-strainer. The cap on the Y-branch can now be removed so the cylindrical screen can also be removed. Clean the screen with compressed air or a small wire brush. Put the screen back in place, replace the cap, re-connect the quick coupler connection and open the valve.

For further service assistance

Call the manufacturer toll free at: 1-866-413-5214 to speak to a Hydronic Service Specialist



## 6.2 Maintenance Frequency Chart

MAINTAINENCE TASKS	Daily	Start of Every	Start of Heating	As
		Project	Season	Necessary
<b>User Performed Tasks:</b>				
Check pressure & temperature gauges for "Normal Function Levels" during operation	√	√		√
Check Aquastat for "Correct Setpoint" during operation	√	√		√
Check LED lights for "Correct Function" during operation	√	√		√
Check Fuel Gauge and order a delivery if necessary ( Propane systems only)	√	√		√
Check HTF Level Gauge and add HTF if necessary	√	√	√	√
If HTF loss is excessive, Check all Hoses & accessories for Leaks and Repair				√
Clean Y-strainer Screen		√	√	√
Examine all hoses and replace or repair any that are cracked or in any way damaged		√	√	√
Lubricate all quick couplers with light oil			√	√
Thoroughly Clean the system inside and out			√	√
Examine The Flue gas exhaust pipe and Rain cap. Clean as needed		√	√	√
Check condensate drainage tube and clean if necessary		√	√	√
Make certain that no flammable materials are anywhere near the heating unit	√	√	√	√
Make certain that nothing is allowed to obstruct the combustion air intake louvers	√	√	√	√
<b>To be Performed by Trained Service Technician</b>				
Perform a Flue Gas Analysis test (using instruments) to confirm clean combustion		√	√	√
Test Ignition Safety Shutoff device on burner		√	√	√
Test Low Water Cut-off Safety switch		√	√	√
Test High Temperature Limit switch		√	√	√
Test High Pressure Limit (blocked flue) switch		√	√	√
Check flue gas passageways for soot or any type of blockage and clean if necessary			√	√

## 7. Troubleshooting

### 7.1 Fault Determination

The CHH-300 is equipped with a group of LED "Indicator Lights". The purpose of these lights is to aid in determining where the fault lies if the heating unit should fail to function properly. The following sequence explains the function each light represents and what to look for if that function fails:

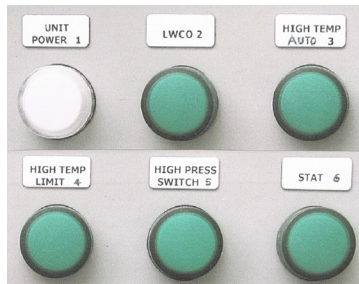

## ! IMPORTANT

If all switches have been turned ON and the system has been operating but has now FAILED, the status of these 6 lights will help to isolate the problem.

**All Lights OFF** indicates.

- A. NO power through the main power switch. Check the following:
  - a. Is main power switch (Fig.9) still turned on?
  - b. Are the circuit breakers (Fig. 14) still turned on?
  - c. Verify external power supply (120V) to inlet plug (Fig. 5).

**#1 Unit Power Light is ON** indicates.

- A. Power is present through main switch. The 2 digital temperature gauges should be ON. If not, use a multi-meter to check the following:
  - a. The 2 transformers (Fig. 16) should show 120VAC in and 6VDC out. If power goes in but not out, replace transformer.
  - b. If there is 6VDC at the digital gauge but it does not illuminate, replace the temp. gauge.
- B. There is no power going through the low water cutoff (LWCO) burner control circuit (Fig. 19).
  - a. Check fluid level in reservoir. Should be at least to the ¼ level. Add if necessary.
  - b. Check, with a multi-meter, for 120V in and out of LWCO switch. If fluid is adequate and there is power in but not out, replace the LWCO switch.
- C. With no power going to the burner limit circuit and the burner panel switch turned ON, the alarm circuit of the LWCO should be energized (120V). This opens contacts in a relay that will prevent the pump from running with no fluid in the system.

**#2 LWCO Light, (plus #1) are ON** indicates.

- A. LWCO switch (Fig. 19) is sensing sufficient glycol in the reservoir and power is going through the switch.
- B. There is no power going through the high temperature auto switch (Fig. 20).
  - a. Check the set points on the high temperature auto switch (Fig. 20) and digital stat (Fig. 8). If the set point of the stat is equal to or higher than the set point of the high temperature auto switch (Fig. 20), the high temperature auto switch will be functioning like a stat and cycling the burner off and on. Light #3 will be cycling in-step with the burner. The digital stat should always be set (maximum 200°F), a few degrees lower than the high temperature auto switch (about 210°F).
  - b. With the actual fluid temperature well below the set point of the high temperature auto switch, check, with a multi-meter, for 120V in and out of the high temperature auto switch (Fig. 20). If there is power in but not out, replace the high temperature auto switch.

**#3 High Temp Auto Light, (plus #1 & #2) are ON** indicates.

- A. Fluid supply temperature is below the set-point of the high temperature auto switch (Fig. 20) and power is going through the switch.
- B. There is no power going through the high temperature Limit switch (Fig. 21).
  - a. Check the set points on the high temperature Limit switch (Fig. 21), the high temperature auto switch (Fig. 20) and digital stat (Fig. 8). If the set points of both the high temperature auto switch and the stat are





equal to or higher than the set point of the high temperature limit switch (Fig. 21), the high temp limit switch will be locked out and the burner off. Light #3 will be off. It will be necessary to push the manual reset button on the front of the high temp limit switch and check the set points of all 3: The high temp auto switch (210°F), the high temp limit switch (220°F) and the digital stat (maximum 200°F).

b. With the high temp limit switch re-set and actual fluid temperature well below the set points of both high temp switches, check, with a multi-meter, for 120V in and out of the high temp limit switch (Fig. 21). If there is power in but not out, replace the high temp limit switch.

#### **#4 High Temp. Limit Light, (plus #1, #2 & #3) are ON** indicates.

- A. Fluid supply temperature is below the set-point of the high temp limit switch (Fig. 21) and power is going through the switch.
- B. There is no power going through the NC contacts of the high pressure switch (Fig. 22)
  - a. Check the set-point of the high pressure switch. Start by turning the adjuster screw all the way counter-clockwise. Then turn the screw clockwise 3 full turns. Push the manual reset button on the pressure switch to restore the circuit.
  - b. Check the air tube connection to the pressure switch and clean if necessary. Push the manual reset button on the pressure switch and the circuit should be restored. If not check for 120 volts going in and out of the control. If power goes in but not out, replace the control.
  - c. If the circuit is restored briefly but it trips again, blockage may have occurred in the flue gas passage way. Clean the flue gas passages in the combustion chamber (see Maintenance article 6.1 G for instructions) as well as the chimney pipe and rain cap. Repeat step a) above.

#### **#5 High Pressure Switch Light, (plus #1, #2, #3 & #4) are ON** indicates.

- A. Pressure in the combustion chamber and flue pipe has not risen above the high limit cutoff point. Power is going through the NC contacts of the high pressure switch (Fig. 22). Indicates no blockage in any of the flue gas passages.
- B. There is no power going through the digital stat switch contacts (Fig. 8).
  - a. The actual supply fluid temperature may have risen high enough that the operator has cycled off. A call-for-heat will be re-established once the supply fluid temperature has dropped to 5°F below set point.
  - b. If the actual supply fluid temperature is well below the set point of the stat (at least 10°F lower), check, with a multi-meter, for 120V in and out of the stat. If there is power in but not out, replace the stat and its sensor.

#### **#6 Stat Light, (plus #1, #2, #3, #4 & #5) are ON** indicates.

- A. The digital stat (Fig. 8) is calling for heat. The burner should be engaged.
- B. If the burner is not functioning, a fault lies within the burner.

## 7.2 Burner Internal Faults

### **Gas Burner, (Natural Gas and Propane Gas)**

Below is a list of scenarios and possible causes for burner failure.

- A. The burner goes through the prepurge period normally. The flame ignites, but the burner goes to lockout within five seconds.
  - a. The phase/neutral lines are reversed. Correct polarity is critical.
  - b. The wiring to ground is absent or ineffective.



# Quest Gas Fired CHH-300 Installation, Operation and Maintenance Instructions

- c. The ionization probe is grounded, or not in contact with the flame, or the circuit to the control box is broken.
- d. The spark interferes with the flame signal due to incorrect setting of the electrode.
- B. The burner goes to lockout after the prepurge period because the flame does not ignite.
  - a. Air has not been fully bled from the gas lines.
  - b. The gas valve is passing too little gas.
  - c. The spark is irregular or not present.
- C. The burner does not start when the thermostat calls for heat.
  - a. The 24 volt switching relay is defective.
  - b. Terminals on the control module are bent or loose
  - c. The motor is defective.
  - d. The capacitor is defective.
  - e. The control box is defective.
  - f. The air pressure switch is not in the normally closed position.
- D. The burner does not go through prepurge, and the control module goes to lockout. The air pressure switch does not change over from normally closed to normally open contacts. This condition exists because there is insufficient air pressure in the combustion head.
- E. For additional information refer to the Riello Manual, 40-G400, included in your data package.

## 7.3 Electrical Schematics

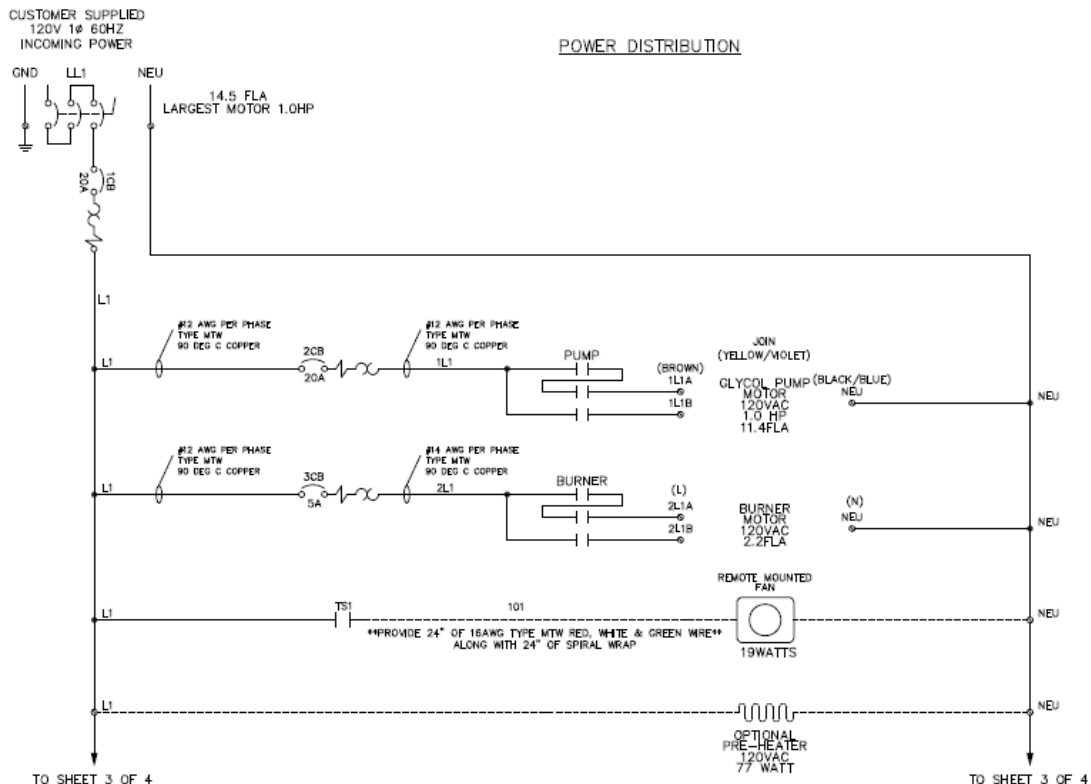

# Quest Gas Fired CHH-300 Installation, Operation and Maintenance Instructions

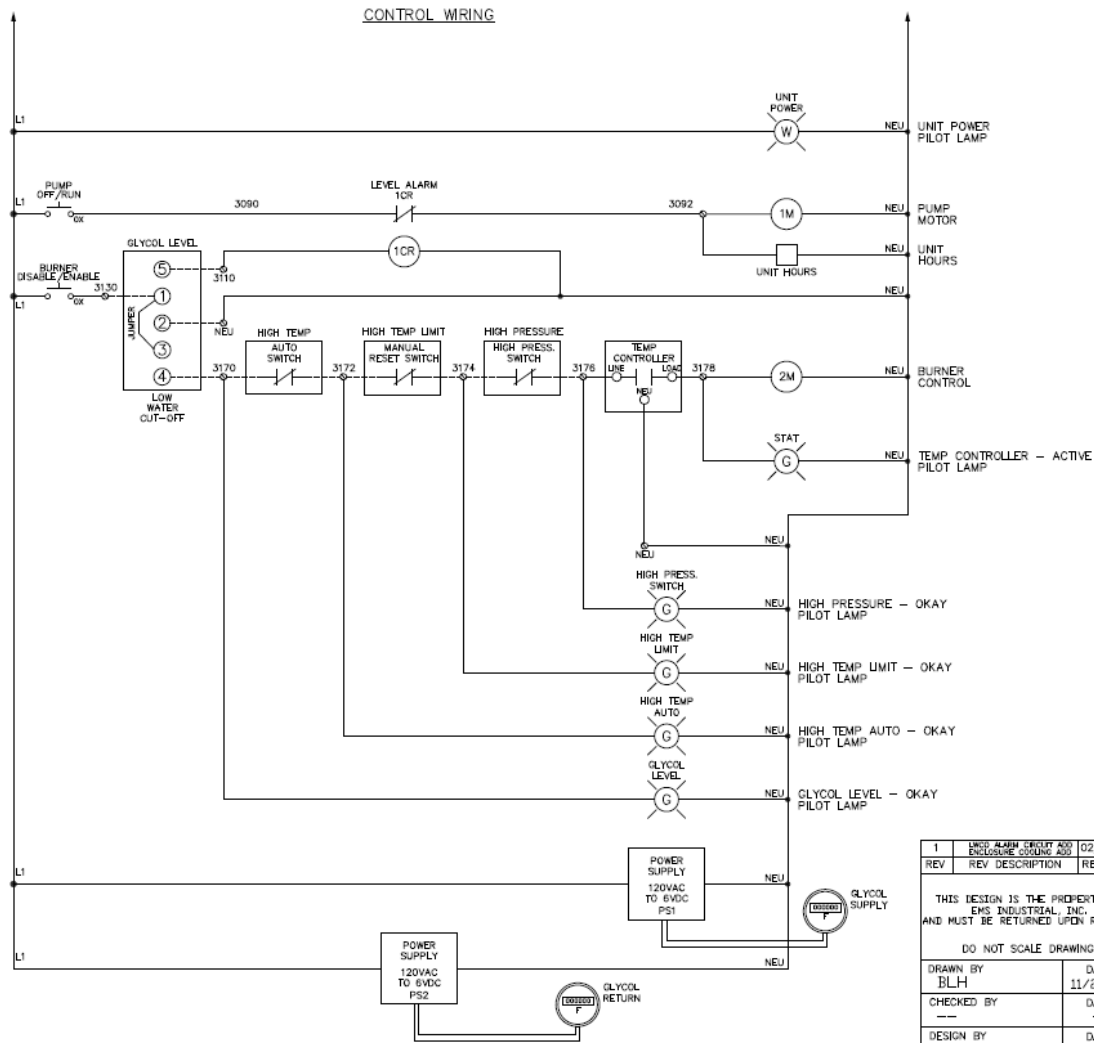

REV	REV DESCRIPTION	REV DATE
1	ENH ALARM CIRCUIT AND ENCLOSURE WIRING	02/28/12

THIS DESIGN IS THE PROPERTY OF EMS INDUSTRIAL, INC. AND MUST BE RETURNED UPON REQUEST

DO NOT SCALE DRAWING

DRAWN BY	DATE
BLH	11/24/09
CHECKED BY	DATE
---	---
DESIGN BY	DATE
BLH	11/24/09

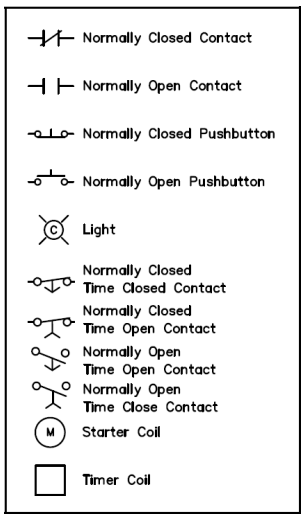

**NOTE:**

- \* CUSTOMER FURNISHED SAFETY DISCONNECT REQUIRED IF MAIN DISCONNECT IS NOT IN SIGHT OF EQUIPMENT
- POWER LUG ON THE COMPONENT
- TERMINAL IN REMOTE JUNCTION/DEVICE BOX
- ⊙ TERMINAL IN MAIN ENCLOSURE TERMINAL
- - - DASHED LINES INDICATE FIELD WIRING AND/OR CUSTOMER SUPPLIED COMPONENTS

WIRE COLOR CODE	
120 VAC CONTROL	RED
AC NEUTRAL (GROUNDED)	WHITE
DC CONTROL	BLUE
0VDC (GROUNDED)	BLUE W/WHITE TRACER OR WHITE W/BLUE TRACER
FOREIGN VOLTAGE	YELLOW
POWER WIRING	BLACK
GROUND	GREEN OR GREEN W/YELLOW TRACER

FIELD WIRING TO BE COPPER WITH 75°C INSULATION



# Quest Gas Fired CHH-300 Installation, Operation and Maintenance Instructions

## Riello Burner Wiring:

### FACTORY WIRING DIAGRAM

**NOTE:**

The SAFETY SWITCH on the 525SE CONTROL BOX is equipped with a contact allowing remote sensing of burner lockout.

The electrical connection is located on the CONTROL BOX terminal 4 as indicated. Should burner lockout occur, the 525SE CONTROL BOX will supply a power source of 120 Vac to the connection terminal.

The maximum allowable current draw on this terminal is 1A.

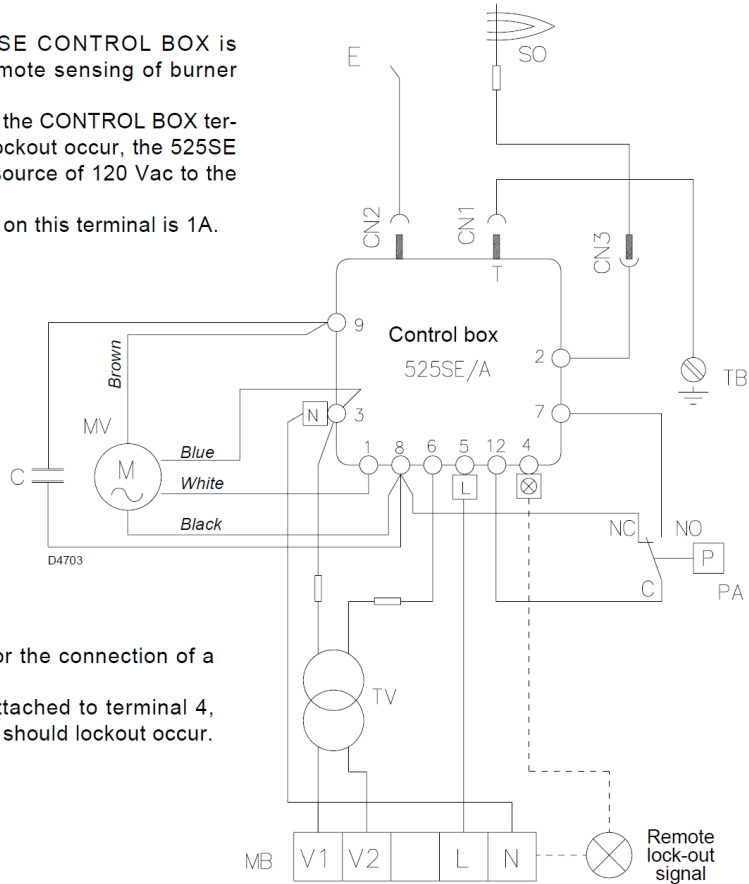

**IMPORTANT:**

Terminal 4 is to be used only for the connection of a remote sensing device.

If a neutral or ground lead is attached to terminal 4, the control box will be damaged should lockout occur.

### FIELD WIRING DIAGRAM

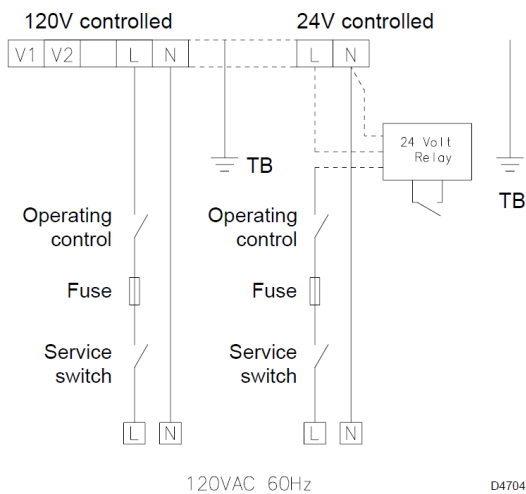

**LEGEND**

- C - Capacitor
- CN... - Connectors
- E - Ignition electrode
- MB - Terminal board
- MV - Motor
- PA - Air pressure switch
- SO - Ionization probe
- TB - Burner earth
- TV - Transformer 24V



## Quest CHH-300 Limited Warranty

### Warrantor:

Therma-Stor LLC  
4201 Lien Rd.  
Madison, WI 53704  
Telephone: 1-866-413-5214

**Who Is Covered:** This warranty extends only to the original end-user of the Quest CHH-300 and may not be assigned or transferred.

**One Year Warranty:** Therma-Stor LLC warrants that, for one (1) year the Quest CHH-300 will operate free from any defects in materials and workmanship, or Therma-Stor LLC will, at its option, repair or replace the defective part(s), free of any charge.

**End-User Responsibilities:** Warranty service must be performed by a Servicer authorized by Therma-Stor LLC. If the end-user is unable to locate or obtain warranty service from an authorized Servicer, the end-user should call Therma-Stor LLC at the above number and ask for the Therma-Stor Service Department., which will then arrange for covered warranty service. Warranty service will be performed during normal working hours.

The end-user must present proof of purchase (lease) upon request, by use of the warranty card or other reasonable and reliable means. The end-user is responsible for normal care. This warranty does not cover any defect, malfunction, etc. resulting from misuse, abuse, lack of normal care, corrosion, freezing, tampering, modification, unauthorized or improper repair or installation, accident, acts of nature or any other cause beyond Therma-Stor LLC' reasonable control.

**Limitations and Exclusions:** If any Quest CHH-300 part is repaired or replaced, the new part shall be warranted for only the remainder of the original warranty period applicable thereto (but all warranty periods will be extended by the period of time, if any, that the Quest CHH-300 Desiccant Dehumidifier is out of service while awaiting covered warranty service).

UPON THE EXPIRATION OF THE WRITTEN WARRANTY APPLICABLE TO THE QUEST CHH-300 OR ANY PART THEREOF, ALL OTHER WARRANTIES IMPLIED BY LAW, INCLUDING MERCHANTABILITY AND FITNESS FOR A PARTICULAR PURPOSE, SHALL ALSO EXPIRE. ALL WARRANTIES MADE BY THERMA-STOR LLC ARE SET FORTH HEREIN, AND NO CLAIM MAY BE MADE AGAINST THERMA-STOR LLC BASED ON ANY ORAL WARRANTY. IN NO EVENT SHALL THERMA-STOR LLC, IN CONNECTION WITH THE SALE, INSTALLATION, USE, REPAIR OR REPLACEMENT OF ANY QUEST CHH-300 OR PART THEREOF BE LIABLE UNDER ANY LEGAL THEORY FOR ANY SPECIAL, INDIRECT OR CONSEQUENTIAL DAMAGES INCLUDING WITHOUT LIMITATION WATER DAMAGE (THE END-USER SHOULD TAKE PRECAUTIONS AGAINST SAME), LOST PROFITS, DELAY, OR LOSS OF USE OR DAMAGE TO ANY REAL OR PERSONAL PROPERTY.

Some states do not allow limitations on how long an implied warranty lasts, and some do not allow the exclusion or limitation of incidental or consequential damages, so one or both of these limitation may not apply to you.

**Legal Rights:** This warranty gives you specific legal rights, and you may also have other rights which vary from state to state.

