

VOLVO TRACKED PAVERS

# P7820C ABG, P8820C ABG

2.5-13.0 m - 175-200 kW



# INTELLIGENT PAVING.

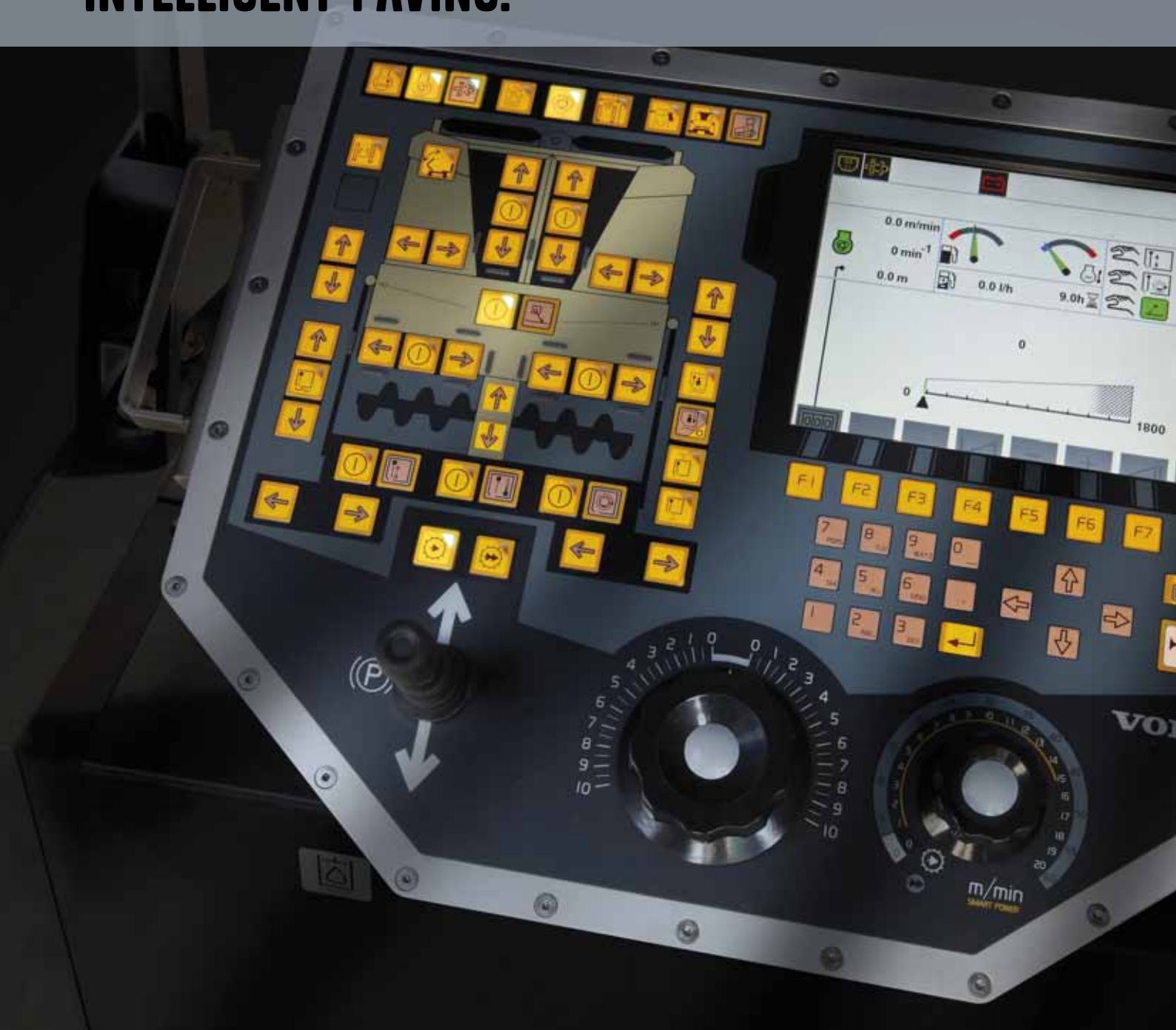

Sit in the driver's seat and feel the power of the Volvo ABG P7820C and P8820C tracked pavers, built for performance and precision in any paving project. Experience unrivalled control at your fingertips with the unique EPM II control panel, designed for easy operation and maximum efficiency. Intelligent paving at its best.



### EPM II control panel for easy operation

Volvo's intuitive EPM II (Electronic Paving Management) control panel, with integrated color screen, allows the operator to quickly select and adjust paver settings while on the move. All control buttons are backlit and arranged by paver location for quick identification. The large panel can be adjusted for the most comfortable operating position.

### Your paving guide

The unique EPM II control panel enables the operator to quickly adjust settings, such as screed temperature and engine parameters, while still monitoring the paving process on the main display.

### Fuel monitoring system

The fuel monitoring system on the EPM II control panel records and displays fuel consumption by day or period so you can plan refuelling and calculate operational costs.

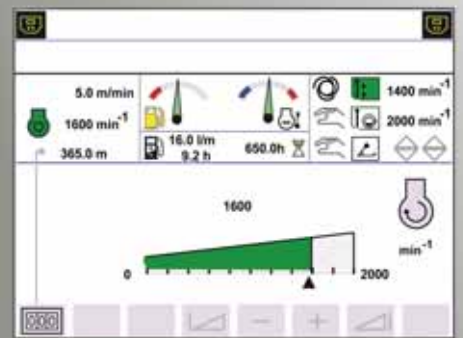

### Smart power reduces fuel and noise

When paving conditions do not require full power, the operator can select the smart power mode on the EPM II control panel to automatically reduce power to 1,600 rpm, resulting in lower noise and up to 30% reduction in fuel consumption.

### Settings Manager

The Settings Manager feature on the EPM II control panel allows the operator to input all paving settings and parameters and save them for re-use on similar paving jobs for consistent paving results.

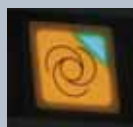

### Automatic on/off button

Allows stop and restart with the same settings while paving.



### Service Interval Manager

Alerts the operator to maintenance and service checks.

# POWER AND PRECISION.

Climb every hill and pave every curve with the Volvo ultra smooth paving system. Achieve instant, precise movement with the turn of a dial, thanks to independent travel drives and excellent traction control. Volvo's high-performance engine supplies the power you need when the road gets steep and the going gets tough.

## Top engine performance



The Volvo high performance D8, V-ACT engine meets Tier 4 Interim/Stage IIIB emissions requirements to deliver high power and low fuel consumption.

## High power, low noise

Volvo engine and components work together to produce lower noise, reducing operator fatigue and noise pollution.



## Perfectly balanced design

The paver has good weight distribution over the large track contact area to provide maximum traction and paver stability. Weight and traction balanced with engine power delivers optimum paving performance.

## Hydraulic track tensioner

The automatic full time track tensioning system maintains correct track tension for smooth operation while reducing track wear and downtime.



#### Precise steering control

Via an easy to use dial on the control panel the electrohydraulic system delivers smooth precise control for curves, straight away and everything in between.

# SEE YOUR WORK FROM EVERY ANGLE.



## All-round visibility

360° view of the entire paving process from the operator seat for optimum safety and productivity. Seats can be extended over the side of the paver for additional visibility. In low ambient light conditions, optional light packages safely illuminate areas around the paver.

Step onto the operator platform and admire your work from 360°. Observe continuous material flow from the large hopper, which holds enough material for continuous paving. See the uniform delivery of material in the auger channel as the conveyor and augers work perfectly together to provide a seamless, smooth mat.

#### Large hopper capacity

The new large hopper design avoids segregation during material flow for a consistent mix of material. Bigger volume supports continuous paving such as under bridges, without stops and starts.

#### Constant material flow

The hopper's capacity, high transfer rate of conveyor and auger work together to provide constantly smooth material flow, free of segregation. Delivering optimum mat quality on any job regardless of width or thickness and paving speed.

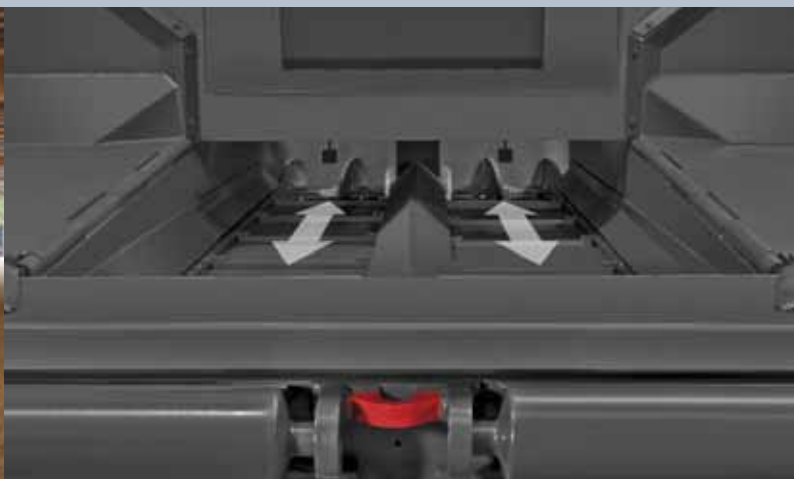

#### Consistent mat thickness

Independent, reversible hydrostatic drives for both bar conveyors and augers ensure a consistent mat thickness on the whole laid width.

# THE PERFECT PAVING PACKAGE.



## All-round visibility

360° view of the whole paving process for improved safety and productivity. The operator seat can be extended over the side of the paver for increased visibility.



## EPM II control panel

Provides an overview of the entire paving process. The large panel with color screen can be repositioned for the most comfortable operating position.

## Your paving guide

The unique EPM II control panel enables the operator to quickly adjust settings, such as screed temperature, while still monitoring the paving process on the main display.

## Large hopper capacity

The new large hopper design avoids segregation during material flow for a consistent mix of material. Bigger volume supports continuous paving.



## Top engine performance,

High performance Volvo D8, V-ACT engine meets Tier 4 Interim/Stage IIIB emissions requirements for high power and low fuel consumption.

## Hydraulic track tensioner

Automatic track tensioner maintains correct track tension and reduces wear for smooth operation.

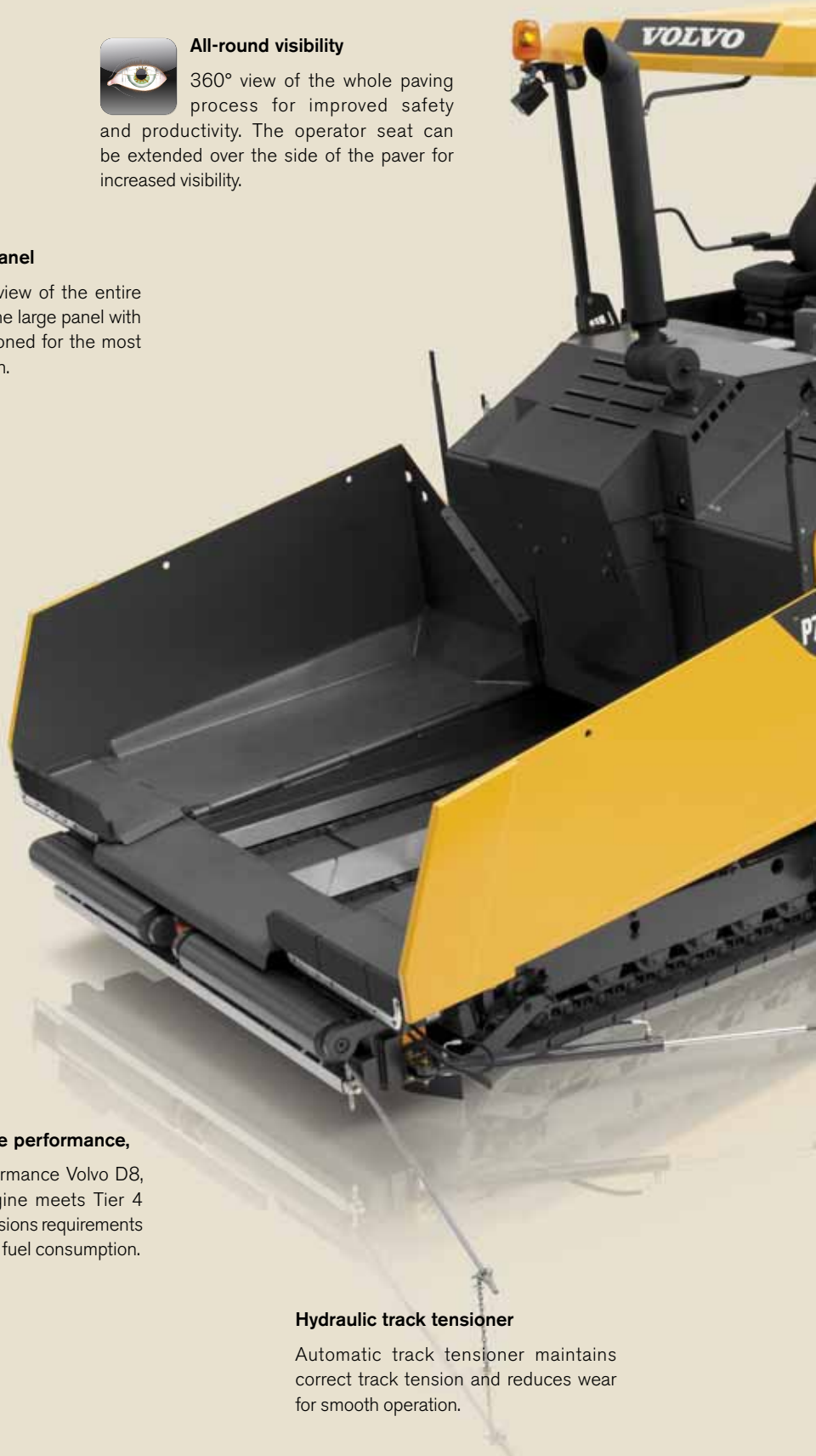





#### **Folding canopy**

Allows you to lower the roof for easy transport.

#### **Durable access doors**

New composite side maintenance doors provide easier service access.

#### **Electric screed heating system**

Variomatic screeds have a dual heating bar arrangement to provide consistent and reliable heating.



#### **The best screed performance**

Volvo screeds provide industry leading performance for the best pavement quality, uniformity and smoothness.



#### **Smooth paving control**

Electronically controlled, independent travel drives for each crawler track offers smooth paving in all operating conditions.

#### **Split tow arms**

Extend tow arm length to allow for improved material flow for wide width paving.

# INDUSTRY LEADING SCREEDS.

Volvo screeds are designed to give you the best pavement quality, uniformity and smoothness. Versatile and effective in paving widths up to 13 meters, these industry-leading screeds can handle a wide range of materials. Thanks to achieving a maximum degree of pre-compaction rolling work is significantly reduced.

## Electric screed heating system.

Volvo's variomatic screeds have a dual heating bar arrangement to provide consistent and reliable heating.

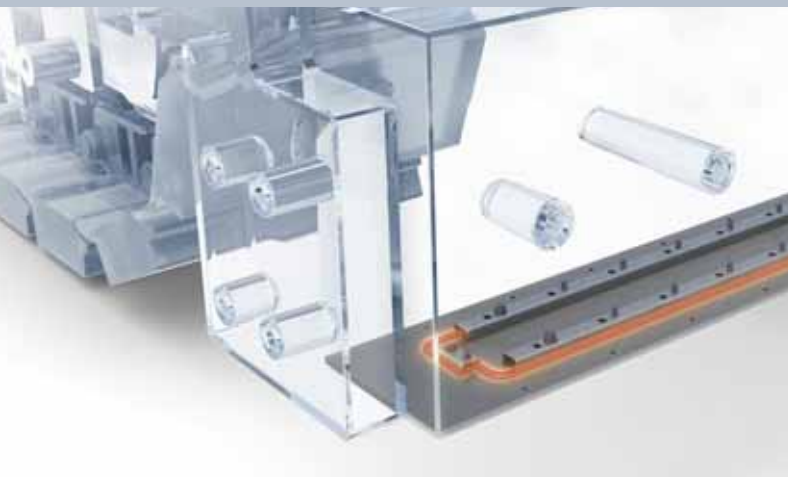

## Screed Control Unit.

The SCU allows the screed operators to control the functions of the screed and material flow.

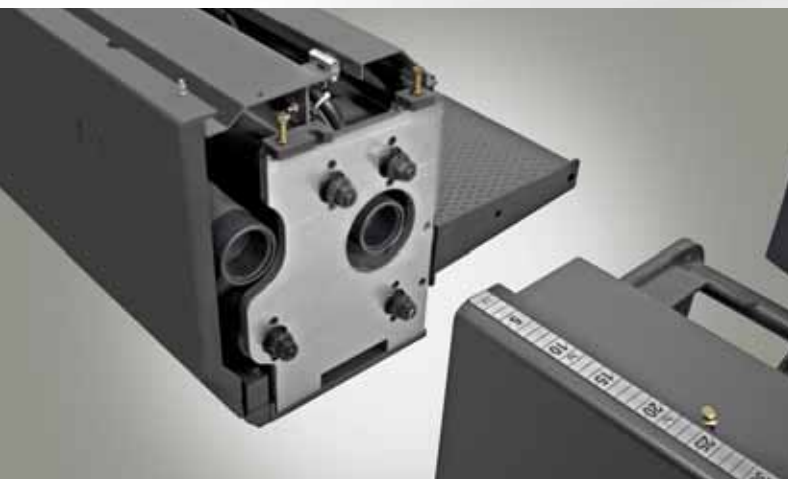

## Unique Quick Coupling

Extensions are added or removed in minutes, with no special tools required, thanks to the unique Volvo Quick Coupling system, saving time and money.

## Unique screed load device

The unique screed load device prevents paving bumps by exerting pressure on the screed for a short period of time after paving starts for consistent mat quality.



#### The best screed performance

Volvo fixed screeds have proven their versatility and effectiveness in paving widths up to 13 meters, while the Variomatic screeds offer the highest flexibility of hydraulically changing paving widths up to 10 meters using extensions. Single or dual tamper systems are available.

# MAINTAIN YOUR UPTIME.



## Safe access to the operator platform

Large steps allow easy and safe access to the operator platform with multi-point handrails and anti-slip platform plates.

## Ease of maintenance

Daily maintenance checks are grouped together with access from the operator's platform for easier, faster and safer checks before paving starts.

## Durable access doors

New composite side maintenance doors provide easier service access.

## Operator platform space

The single level operator platform is comfortably and ergonomically designed for ease of operation and movement with adjustable seats and control panel.

## Backup circuits

All primary circuits have a backup system and interchangeable components to keep you in operation.

## Interchangeable ECU

The ECUs are interchangeable and contain a self-diagnostic system for reduced downtime.

## Sealed bearings

The conveyor and auger systems are equipped with 'sealed for life' bearings for reduced operating cost.



# SPECIFICATIONS.

		P7820C	P8820C
<b>Diesel Engine</b>			
Manufacturer		Volvo	
Model		D8H GEE4	D8H GEE4
Output @ installed speed	kW	175 @ 1800 rpm	200 @ 2000 rpm
Coolant		Liquid	
Fuel tank capacity	l	300	
Exhaust emission		COM IIIB / EPA Tier 4i	
<b>Paving</b>			
Output ( theoretical) <sup>1</sup>	t/h	900	1 100
Mat thickness (max)	mm	300	
<b>Speed</b>			
Paving (max)	m/min	20	
Transport (max)	km/h	3,6	
<b>Carriage</b>			
Length	mm	2 965	3 085
Width ( track plates )	mm	300	325
<b>Conveyor</b>			
Hopper capacity	t	13,5	14
Numbers of conveyors		2	
Conveyor speed (max)	m/min	24	
<b>Auger</b>			
Speed (max)	1/min	95	100
Diameter	mm	360	
<b>Electrics</b>			
Battery voltage	V	24	
<b>Dimensions</b>			
Length with Vario Screed (Walkway up)	mm	6 137	6 427
Length with Fixed Screed	mm	5 929	6 237
Width	mm	2 548	2 548
Height	mm	3 785	3 945
Height (transport)	mm	2 917	3 075
<b>Weight<sup>2</sup></b>			
Tractor unit	kg	15 600	17 700

<sup>1</sup> The actual paving output depends upon the mat thickness, the paving width and paving speed and will vary according to paving conditions prevailing on your jobsite. Please approach us and we will be pleased to assist you in calculating the paving output for your particular paving project.

<sup>2</sup> Approximate weight without screed / with standard hopper / fuel tank half full / towing arms separated / 75kg driver

## CA. OPERATING WEIGHTS<sup>3</sup> OF SCREEDS IN KG (LB)

	P7820C, P8820C							P8820C	
	2,5 m	5 m	6 m	7,5 m	9 m	10 m	11 m	12 m	13 m
At working width									
VB 78 ETC		3 500		5 682	6 803				
VB 78 GTC		3 580		5 812	6 973				
VDTV 78 ETC		3 620		5 932	7 153				
VDTV 78 GTC		3 700		6 072	7 333				
VB 79 ETC		3 630		5 812	6 933				
VDTV 79 ETC		4 000		6 312	7 533				
VB 88 ETC			3 720	5 442	5 961	6 522			
VB 88 GTC			3 800	5 562	6 121	6 692			
VDTV 88 ETC			4 350	6 172	6 791				
VDTV 88 GTC			4 420	6 282	6 941				
VB 89 ETC			4 100	5 822	6 341				
VDTV 89 ETC			4 470	6 292	6 911				
MB 122	1 800		4 752	6 017	7 282	8 126	8 969	9 813	10 656
VDT 121	2 100		5 052	6 317	7 582			10 113	10 956

<sup>3</sup> Including auger extensions, channel plates etc.

# SPECIFICATIONS.

## DIMENSIONS

		P7820C	P8820C
A	mm	6 388	6 678
B	mm	2 965	3 085
C	mm	415	485
D	mm	548	548
E	mm	1 615	1 625
F	mm	360±60	360±60
G	mm	2 140	2 140
H	mm	3 793	3 950
I	mm	1 373	1 397
J	mm	608	630
K	mm	525	528
L	mm	435	438
M	mm	13°	13°
N	mm	160	160
O	mm	438	433
P	mm	1 614	1 771
Q	up mm	3 785	3 942
	down mm	2 917	3 075
R	open mm	3 252	3 337
	closed mm	2 476	2 560
S	mm	3 168	3 253
T	mm	2 495	2 495
U	mm	320	320
V	mm	2 500/ 3 000	2 500/ 3 000
W	mm	5 000/ 6 000	5 000/ 6 000
X	mm	300	325
Y	mm	2 269	2 335
Z	mm	300	770

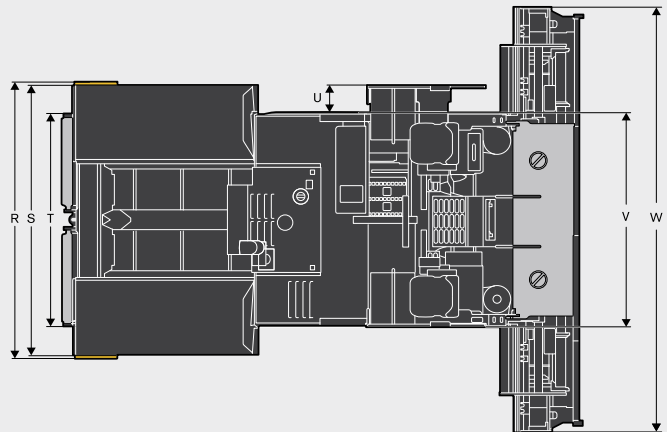
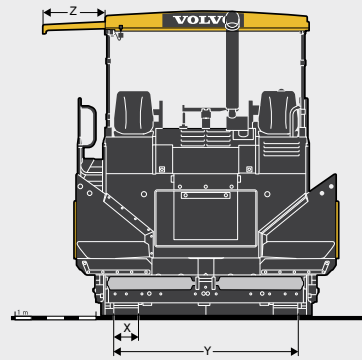
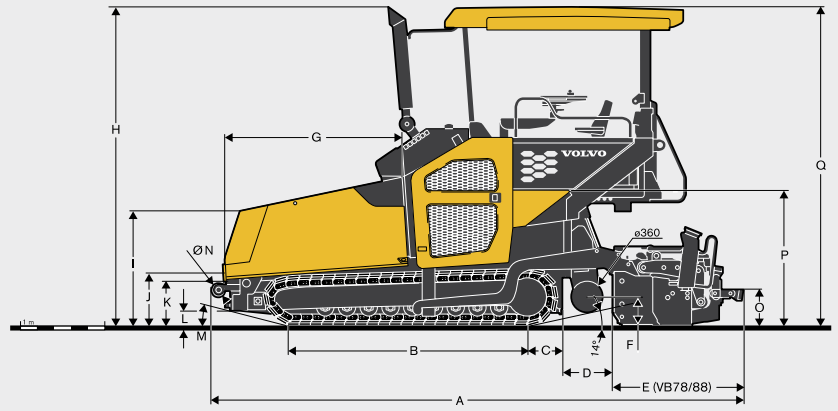

# EQUIPMENT.

## STANDARD EQUIPMENT

	P7820C	P8820C
<b>Engine</b>		
Volvo Diesel engine, COM IIIB/EPA Tier 4i	•	•
<b>Drive</b>		
Electronic drive control	•	•
Lifetime lubricated crawler track rollers	•	•
Forged and hardened crawler track links	•	•
Automatic track tensioner	•	•
<b>Material Management</b>		
Large truck buffer rollers with 160 mm Ø	•	•
Four individual hydrostatic drives for conveyors and augers	•	•
Hydraulic auger height adjustment	•	•
Reversible direction of auger rotation	•	•
Auger speed control ON/OFF	•	•
<b>Electronics</b>		
Electronic Paver Management (EPM2)	•	•
Smart power	•	•
Settings Manager	•	•
Service Interval Manager	•	•
Adjustable and revolving control unit	•	•
Electric switch cabinet	•	•
Battery master switch	•	•
Two external control panels for the paving screed	•	•
<b>Structure</b>		
Two seats, laterally extendable	•	•
Anti-vandalism kit	•	•
<b>Screed</b>		
Screed towing arms, continuous version	•	
Split towing arms		•
Hydraulics for Vario screeds with tamper and vibration	•	
Hydraulics for Vario screeds with double tamper and vibration & man. adjust. screeds		•
Screed lock	•	•
<b>Lights</b>		
Four working lights	•	•
Driver's compartment lighting	•	•
<b>Environmental</b>		
Sound insulation	•	•

## OPTIONAL EQUIPMENT

	P7820C	P8820C
<b>Engine</b>		
Fuel transfer pump	•	•
<b>Material Management</b>		
Individual operating hopper wings	•	•
Hydraulically operated front apron	•	•
Proportional control of conveyor		•
Reversible conveyor	•	•
Proportional Ultrasonic Sensor auger control according to material requirements	•	•
Central lubrication	•	•
<b>Electronics</b>		
Levelling systems (please see price list)	•	•
Auxiliary control panel	•	•
Additional sockets 230V	•	•
<b>Structure</b>		
Deluxe seats with heating	•	•
GFK all-weather roof with manual-hydraulic folding device	•	•
Front windscreen (only in conjunction with all-weather roof)	•	•
Tarpaulin for sides	•	•
Special paintwork (according to RAL colour code, excluding metallic paintwork)	•	•
<b>Screed</b>		
Split towing arms	•	
Hydraulics for Vario screeds with double tamper and vibration & man. adjust. screeds	•	
Screed anti-climbing lock	•	•
Screed tensioning device	•	•
Screed assist	•	•
Screed load device	•	•
Hydraulic height adjustment of extendable screeds	•	•
<b>Lights</b>		
Xenon Floodlighting (only in conjunction with all-weather roof)	•	•
Two additional lights (rear)	•	•
Auger lighting	•	•
Warning beacon	•	•
<b>Environmental</b>		
Extractor for bituminous fumes	•	•
Emulsions spraying system	•	•
Heavy-duty spray cleaning gun	•	•
Biodegradeable hydraulic oil	•	•

Standard equipment and options may vary based on local markets. Consult local sales when building your next paver.

# VOLVO CONSTRUCTION EQUIPMENT



Volvo Construction Equipment is different. Our machines are designed, built and supported in a different way. That difference comes from an engineering heritage of over 175 years. A heritage of thinking first about the people who actually use the machines. About how to help them be safer, more comfortable, more productive. About the environment we all share. The result of that thinking is a growing range of machines and a global support network dedicated to helping you do more. People around the world are proud to use Volvo.

Not all products are available in all markets. Under our policy of continuous improvement, we reserve the right to change specifications and design without prior notice. The illustrations do not necessarily show the standard version of the machine.

## **VOLVO**

**Volvo Construction Equipment**  
[www.volvoce.com](http://www.volvoce.com)

Ref. No 20029045-A  
2011-11  
Volvo, Global Marketing

English.21  
PAT